

**IT ATTENZIONE:**

LA SICUREZZA DELL'APPARECCHIO E' GARANTITA SOLO CON L'USO APPROPRIATO DELLE SEGUENTI ISTRUZIONI; PERTANTO E' NECESSARIO CONSERVARLE.

**EN WARNING:**

THE SAFETY OF THIS FIXTURE IS GUARANTEED ONLY IF YOU COMPLY WITH THESE INSTRUCTIONS; REMEMBER TO CONSERVE IN A SAFE PLACE.

**FR ATTENTION:**

LA SECURITE DE L'APPAREIL N'EST GARANTIE QU'EN CAS D'UTILISATION CORRECTE DES INSTRUCTIONS SUIVANTES; IL FAUT PAR CONSEQUENT LES CONSERVER.

**DE ACHTUNG:**

DIE SICHERHEIT DES GERÄTES WIRD NUR DURCH SACHGEMÄSSE BEFOLGUNG NACHSTEHENDER ANWEISUNGEN GEWÄHRLEISTET; IHRE AUFBEWAHRUNG IST DESHALB SEHR WICHTIG.

**NL OPGELET:**

DE VEILIGHEID VAN DI ATOESTEL IS SLECHTS DAN GEGARANDEERD ALS INDIEN DE VOLGENDE INSTRUCTIES STRIKT WORDEN TOEGEPAST; DAAROM MOET MEN ZE OOK BEWAREN.

**ES ATENCION:**

LA SEGURIDAD DEL APARATO SE GARANTIZA SOLO CUMPLIENDO CUIDADOSAMENTE LAS SIGUIENTES INSTRUCCIONES; POR ELLO, ES NECESARIO CONSERVARLAS.

**DA BEMÆRK:**

SIKKERHEDEN VED BRUG AF ARMATURET KAN KUN GARANTERES, HVIS DISSE ANVISNINGER FØLGES; SØRG DERFOR FOR AT GEMME DEM.

**NO ADVARSEL:**

SIKKERHETEN TIL DETTE APPARATET GARANTERES KUN HVIS DU OVERHOLDER DISSE INSTRUKSJONENE; HUSK Å OPPBEVARE DEM PÅ ET TRYGT STED.

**SV OBSERVERA!**

UTRUSTNINGENS SÄKERHET KAN ENDAST GARANTERAS OM DESSA ANVISNINGAR RESPEKTERAS I DETALJ. SPARA DÄRFÖR DESSA ANVISNINGAR FÖR FRAMTIDA KONSULTATION.

**RU ВНИМАНИЕ:**

МЫ ГАРАНТИРУЕМ БЕЗОПАСНУЮ ЭКСПЛУАТАЦИЮ ИЗДЕЛИЯ ТОЛЬКО ПРИ СОБЛЮДЕНИИ СЛЕДУЮЩИХ ИНСТРУКЦИЙ; С ЭТОЙ ЦЕЛЬЮ НЕОБХОДИМО СОХРАНИТЬ ДАННУЮ БРОШЮРУ.

**ZH 警告**

为确保该装置安全，请遵守操作指示；并于安全场所放置。

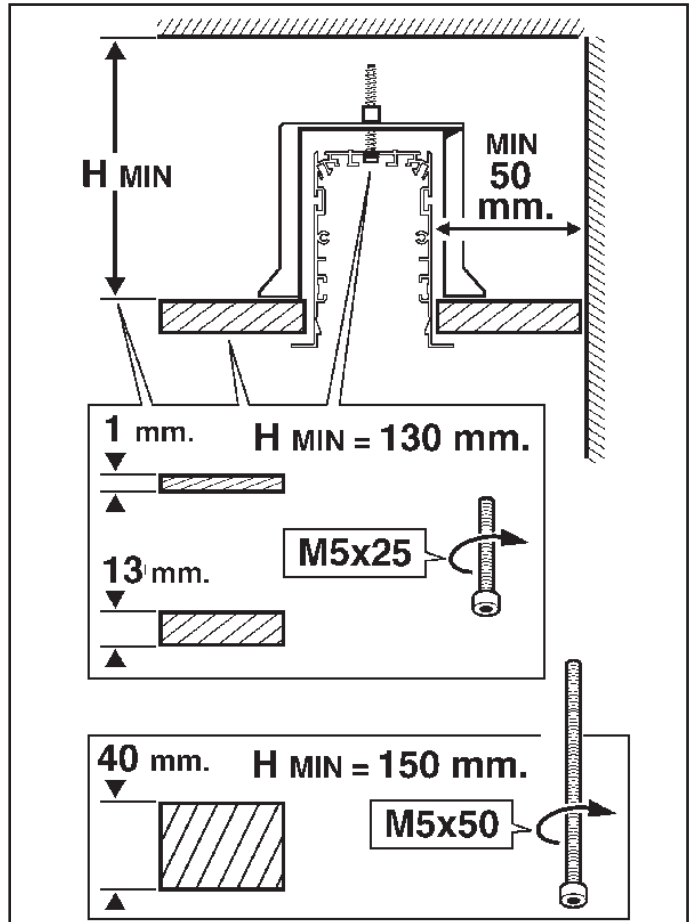

## OPENING CALCULATION

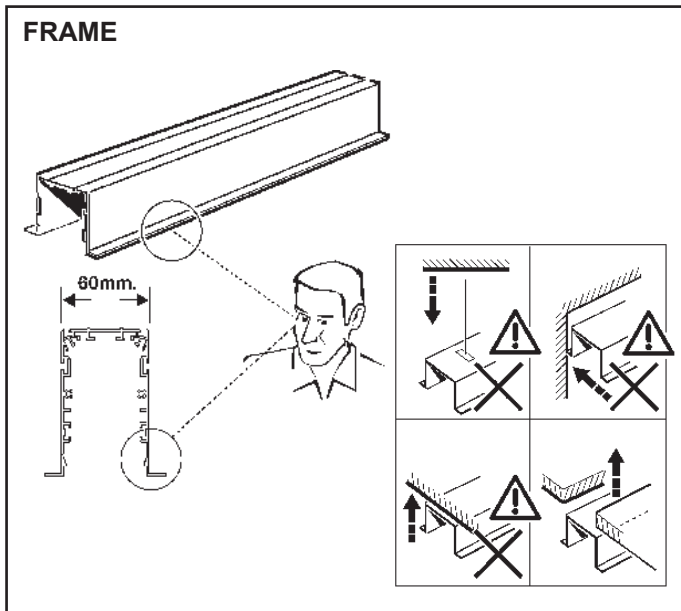
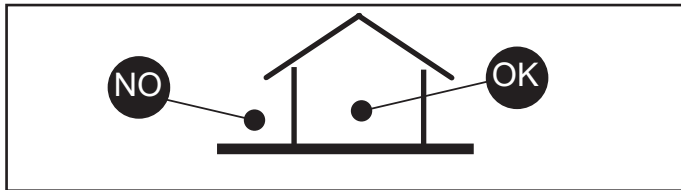
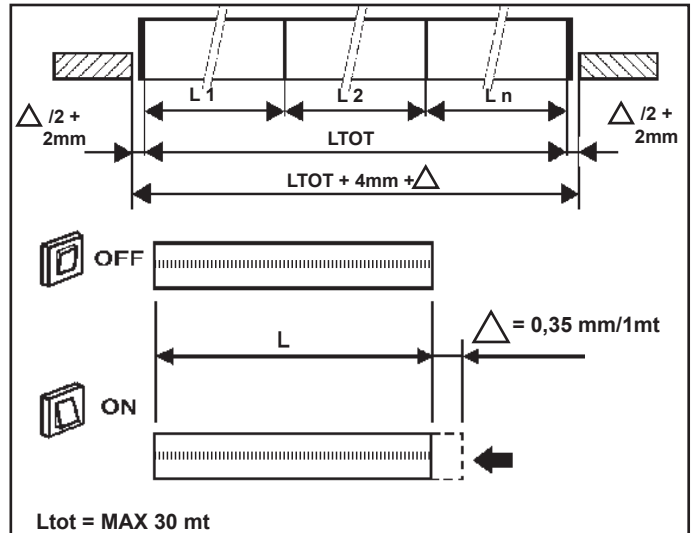
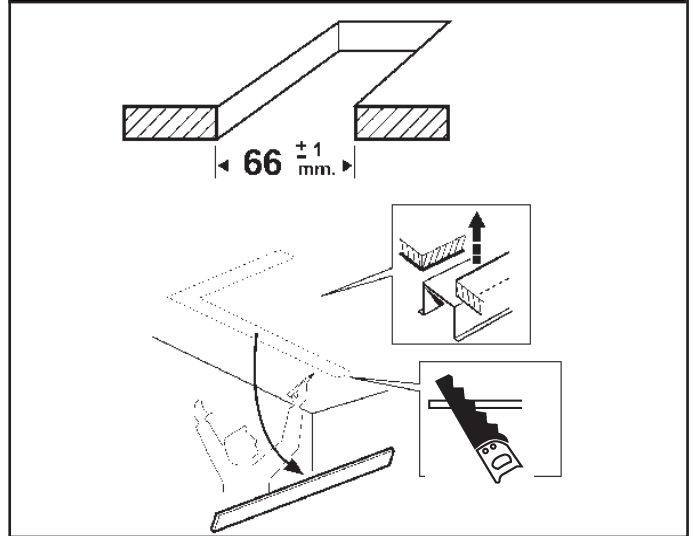

# PRODUCT DIMENSIONS

ART.	L (mm)
QA84 - QB64 - QZ63 - QZ91	612
QA85 - QB65 - QZ64 - QZ92	1208
QA86 - QB66 - QZ65 - QZ93	2397
QA87 - QB67 - QZ66 - QZ94	3596
QA88 - QB68 - QZ67 - QZ95	898
QA89 - QB69 - QZ68 - QZ96	3596
QX47	1192
QX54	2384

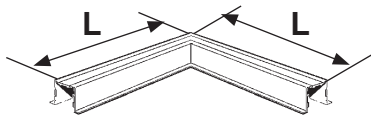
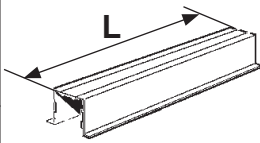

ART.	L (mm)
QB00 - QB01 - QB02 - QB03 QB32 - QB33 - QB34 - QB35 QB80 - QB81 - QB82 - QB83 QZ77 - QZ79 - QZ78 - QZ80 QZ81 - QZ83 - QZ82 - QZ84 R051 - R053 - R052 - R054	642 x 642

Non serrare a fondo  
Do not tighten fully  
Ne pas serrer à fond  
Nicht vollständig festziehen  
Niet geheel vast draaien  
No atornille a fondo  
Skrú ikkje helt i bund  
Ikke trekk helt til  
Dra inte át till botten  
Не закручивать до упора  
请勿完全拧紧

**ACCESSORY  
END CUP  
ART. PB32 - MWP7**

Serrare a fondo  
Tighten firmly  
Serrer à fond  
Fest einrasten  
Goed aanschroeven  
Enrosar en firme  
Skrues i bund  
Trek til godt  
Dra át till botten  
закручивать до упора  
完全拧紧

**IT** Per le posizioni di installazione, attenersi a quelle illustrate, eventualmente contattare la iGuzzini.

**EN** All installation positions must comply with those illustrated. In the event of any doubt, contact iGuzzini.

**FR** Pour les positions d'installation, se conformer aux positions illustrées ; contacter la société iGuzzini en cas de nécessité

**DE** Für die Einbaupositionen die Abbildungen beachten. Eventuell iGuzzini kontaktieren.

**NL** Houd u voor de installatieposities aan degene die zijn weergegeven. Neem eventueel contact op met iGuzzini

**ES** Respetar las posiciones de instalación ilustradas y, en caso de duda, contactar con iGuzzini

**DA** For installationspositioner skal man holde sig til de viste, og eventuelt kontakte iGuzzini

**NO** For installasjonsplassingene henviser vi til illustrasjonene, eller ta eventuelt kontakt med iGuzzini

**SV** Följ de angivna positionerna för installationen. Kontakta vid behov iGuzzini

**RU** При выборе положения для монтажа следует обратиться к проиллюстрированным либо обратиться в компанию iGuzzini

**ZH** 安装位置请参考图示，必要时也可联系iGuzzini

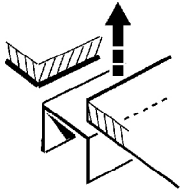

## iN60 Led (MINIMAL) recessed application

**IT Attenzione:**

La sicurezza dell'apparecchio e' garantita solo con l'uso appropriato delle seguenti istruzioni; pertanto e' necessario conservarle.

**EN Warning:**

The safety of this fixture is guaranteed only if you comply with these instructions; remember to conserve in a safe place.

**FR Attention:**

La sécurité de l'appareil n'est garantie qu'en cas d'utilisation correcte des instructions suivantes; il faut par conséquent les conserver.

**DE Achtung:**

Die sicherheit des gerätes wird nur durch sachgemässe befolgung nachstehender anweisungen gewährleistet; ihre aufbewahrung ist deshalb sehr wichtig.

**NL Opgelet:**

De veiligheids van dit toestel is slechts dan gegarandeerd als indien de volgende instructies strikt worden toegepast: daarom moet men ze ook bewaren.

**ES Atencion:**

La seguridad del aparato se garantiza solo cumpliendo cuidadosamente las siguientes instrucciones; por ello, es necesario conservarlas.

**DA Bemærk:**

Sikkerheden ved brug af armaturet kan kun garanteres, hvis disse anvisninger følges; sørg derfor for at gemme dem.

**NO Advarsel:**

Sikkerheten til dette apparatet garanteres kun hvis du overholder disse instruksjonene; husk å oppbevare dem på et trygt sted.

**SV Observera:**

Utrustningens säkerhet kan endast garanteras om dessa anvisningar respekteras i detalj. Spara därför dessa anvisningar för framtida konsultation.

**RU Внимание:**

Мы гарантируем безопасную эксплуатацию изделия только при соблюдении следующих инструкций; с этой целью необходимо сохранить данную брошюру.

**ZH 警告:**

为确保该装置安全, 请遵守操作指示; 并于安全场所放置。

**AR تحذير:** لا يمكن ضمان سلامة هذا الجهاز إلا إذا التزمت بهذه التعليمات. يجب حفظها في مكان آمن.

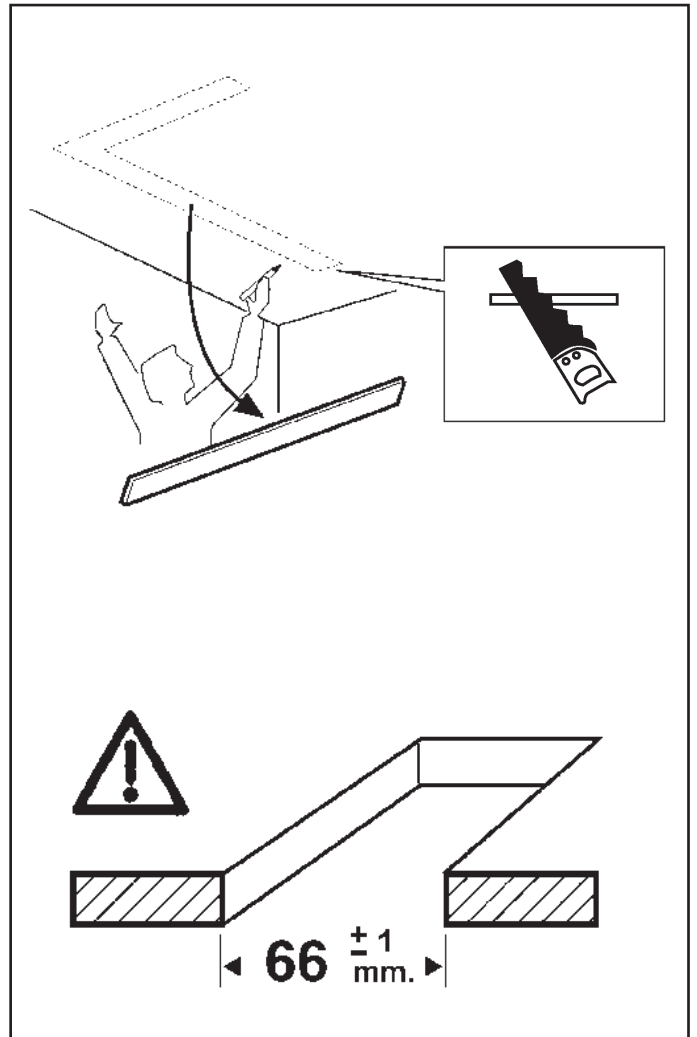
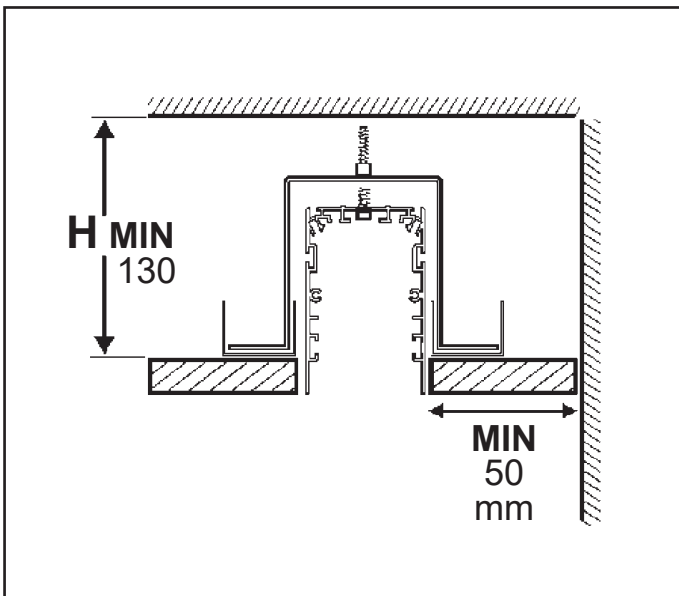
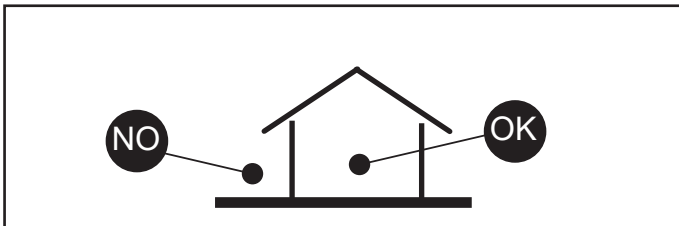

## OPENING CALCULATION

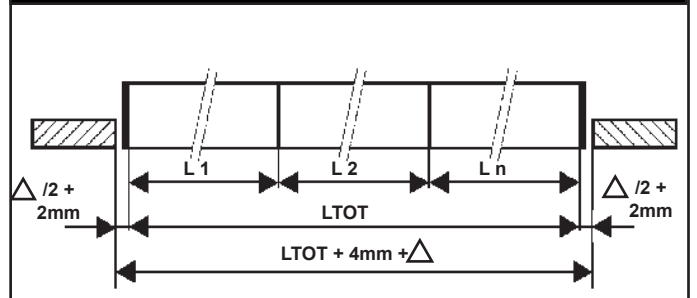

Ltot = MAX 30 mt

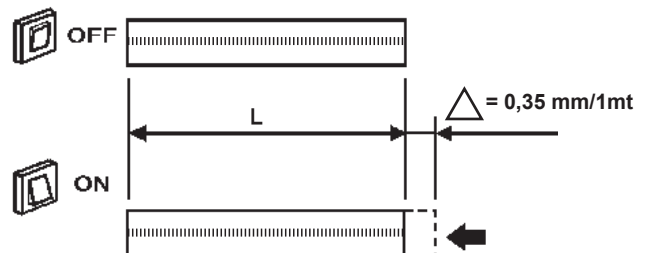

# PRODUCT DIMENSIONS

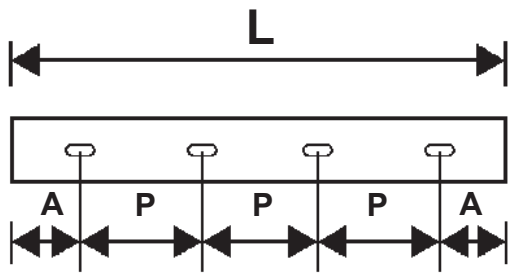

ART.	L (mm)	P (mm)	A (mm)	
QA90 - QB70 - QZ57 - QZ85	612	212	200	2
QA91 - QB71 - QZ58 - QZ86	1208	500	354	2
QA92 - QB72 - QZ59 - QZ87	2397	800	399	3
QA93 - QB73 - QZ60 - QZ88	3596	980	328	4
QA94 - QB74 - QZ61 - QZ89	898	498	200	2
QA95 - QB75 - QZ62 - QZ90	3596	980	328	4
QX48	1192	500	346	2
QX55	2384	800	392	3

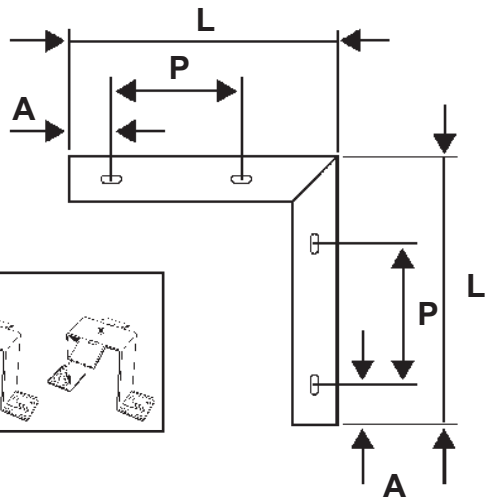

art. MWH6

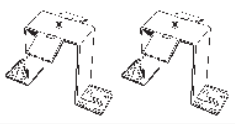

ART.	L (mm)	P (mm)	A (mm)	
QB04 - QB05 - QB06 - QB07 QB36 - BQ37 - QB38 - QB39 QB84 - QB85 - QB86 - QB87 QZ69 - QZ70 - QZ71 - QZ72 QZ73 - QZ74 - QZ75 - QZ76 QZ97 - QZ98 - QZ99 - R050	642 x 642	250	200	4

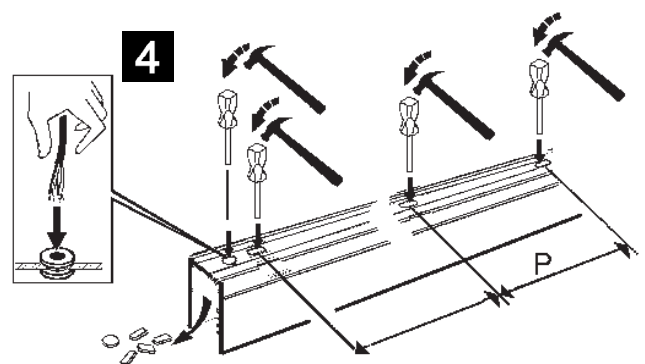
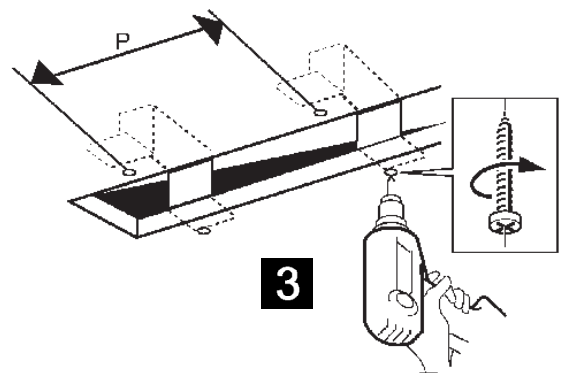
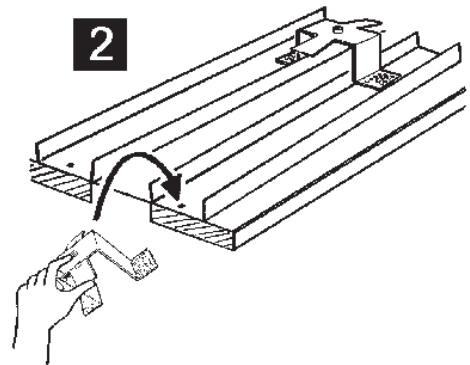
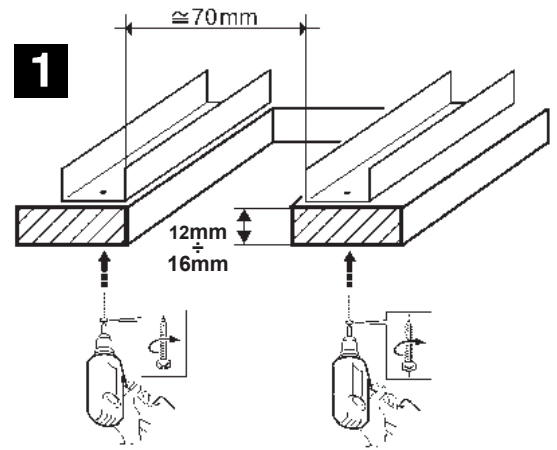

ACCESSORY  
END CUP  
ART. PB33 - MWP6

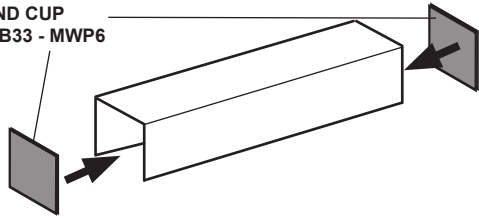

5

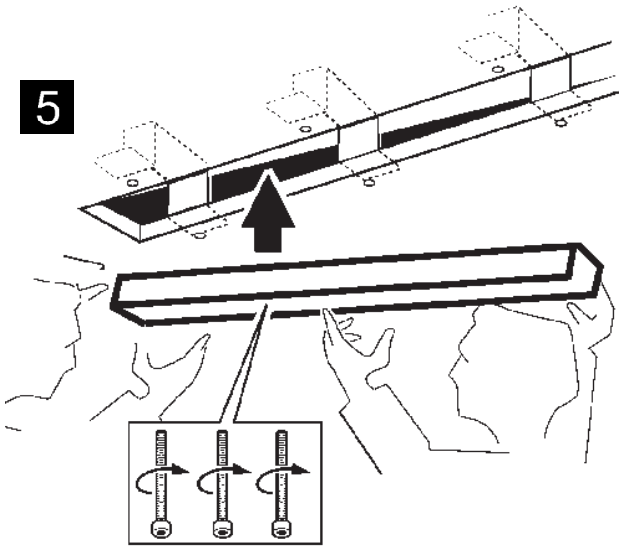

NO

OK

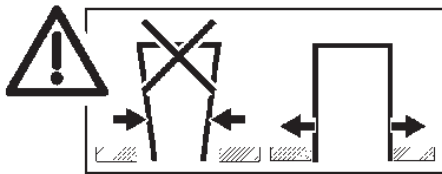

6

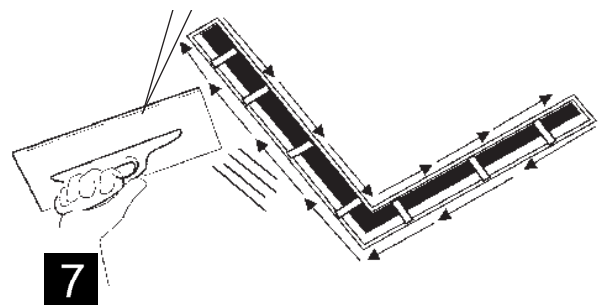
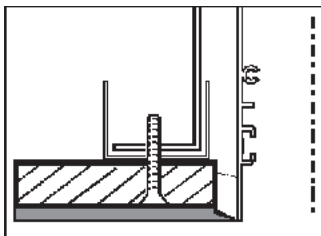

7

IT Utilizzare silicone di tipo acrilico (verniciabile)

EN Use silicone of acrylic type (paintable)

FR Utiliser du silicone acrylique (pouvant être peint)

DE Benutzen Sie (überstreichbares) Acryl

NL Gebruik een acrylsilicone (overschilderbaar)

ES Utilizar silicona de tipo acrilico (pintable)

DA Brug akrylsilicone (som kan lakeres)

NO Bruk silikon av akrylisk type (overmalbar)

SV Använd silikon av akryltyp (målningsbar)

RU Используйте силикон акрилового типа (под покраску)

ZH 使用丙烯酸類矽膠 (可塗漆)

AR

استخدم سيليكو اكريليك (قابل الطلاء)

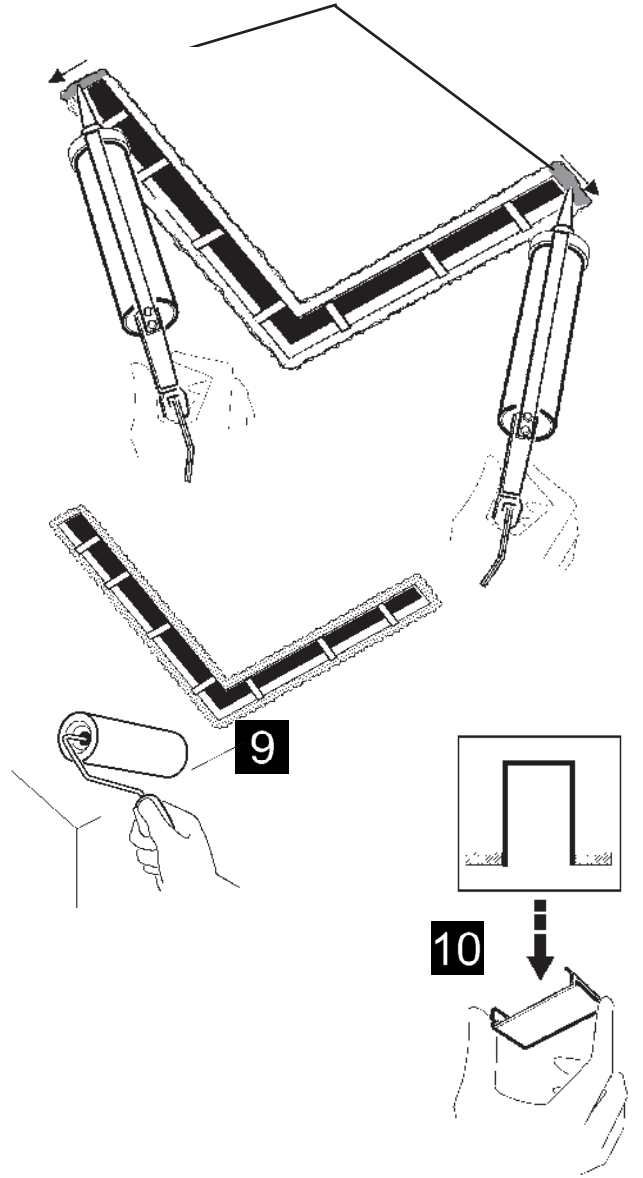

9

10

IT Per le posizioni di installazione, attenersi a quelle illustrate, eventualmente contattare la iGuzzini.

EN All installation positions must comply with those illustrated. In the event of any doubt, contact iGuzzini.

FR Pour les positions d'installation, se conformer aux positions illustrées ; contacter la société iGuzzini en cas de nécessité.

DE Für die Einbaupositionen die Abbildungen beachten. Eventuell iGuzzini kontaktieren.

NL Houd u voor de installatieposities aan degene die zijn weergegeven. Neem eventueel contact op met iGuzzini.

ES Respetar las posiciones de instalación ilustradas y, en caso de duda, contactar con iGuzzini.

DA For installationspositioner skal man holde sig til de viste, og eventuelt kontakte iGuzzini.

NO For installasjonsposeringene henviser vi til illustrasjonene, eller ta eventuelt kontakt med iGuzzini.

SV Följ de angivna positionerna för installationen. Kontakta vid behov iGuzzini.

RU При выборе положения для монтажа следует обратиться к проиллюстрированным либо обратиться в компанию iGuzzini.

ZH 安装位置请参考图示，必要时也可联系iGuzzini.

AR في ما يتعلق بأوضاع التركيب، التزم بما هو موضح ومحدد، إذا دعت الضرورة اتصل ب iGuzzini

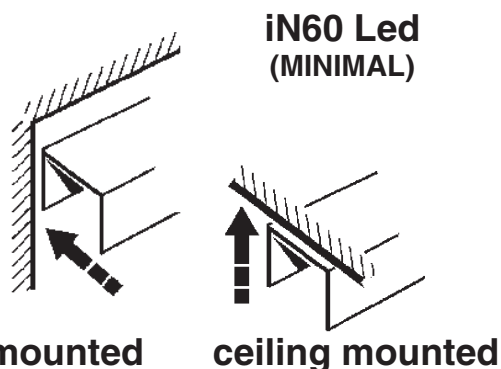

**IT ATTENZIONE:**

LA SICUREZZA DELL'APPARECCHIO E' GARANTITA SOLO CON L'USO APPROPRIATO DELLE SEGUENTI ISTRUZIONI; PERTANTO E' NECESSARIO CONSERVARLE.

**EN WARNING:**

THE SAFETY OF THIS FIXTURE IS GUARANTEED ONLY IF YOU COMPLY WITH THESE INSTRUCTIONS; REMEMBER TO CONSERVE IN A SAFE PLACE.

**FR ATTENTION:**

LA SECURITE DE L'APPAREIL N'EST GARANTIE QU'EN CAS D'UTILISATION CORRECTE DES INSTRUCTIONS SUIVANTES; IL FAUT PAR CONSEQUENT LES CONSERVER.

**DE ACHTUNG:**

DIE SICHERHEIT DES GERÄTES WIRD NUR DURCH SACHGEMÄSSE BEFOLGUNG NACHSTEHENDER ANWEISUNGEN GEWÄHRLEISTET; IHRE AUFBEWAHRUNG IST DESHALB SEHR WICHTIG.

**NL OPGELET:**

DE VEILIGHEID VAN DI ATOESTEL IS SLECHTS DAN GEGARANDEERD ALS INDIEN DE VOLGENDE INSTRUCTIES STRIKT WORDEN TOEGEPAST; DAAROM MOET MEN ZE OOK BEWAREN.

**ES ATENCION:**

LA SEGURIDAD DEL APARATO SE GARANTIZA SOLO CUMPLIENDO CUIDADOSAMENTE LAS SIGUIENTES INSTRUCCIONES; POR ELLO, ES NECESARIO CONSERVARLAS.

**DA BEMÆRK:**

SIKKERHEDEN VED BRUG AF ARMATURET KAN KUN GARANTERES, HVIS DISSE ANVISNINGER FØLGES; SØRG DERFOR FOR AT GEMME DEM.

**NO ADVARSEL:**

SIKKERHETEN TIL DETTE APPARATET GARANTERES KUN HVIS DU OVERHOLDER DISSE INSTRUKSJONENE; HUSK Å OPPBEVARE DEM PÅ ET TRYGT STED.

**SV OBSERVERA!**

UTRUSTNINGENS SÄKERHET KAN ENDAST GARANTERAS OM DESSA ANVISNINGAR RESPEKTERAS I DETALJ. SPARA DÄRFÖR DESSA ANVISNINGAR FÖR FRAMTIDA KONSULTATION.

**RU ВНИМАНИЕ:**

МЫ ГАРАНТИРУЕМ БЕЗОПАСНУЮ ЭКСПЛУАТАЦИЮ ИЗДЕЛИЯ ТОЛЬКО ПРИ СОБЛЮДЕНИИ СЛЕДУЮЩИХ ИНСТРУКЦИЙ; С ЭТОЙ ЦЕЛЬЮ НЕОБХОДИМО СОХРАНИТЬ ДАННУЮ БРОШЮРУ.

**ZH 警告**

为确保该装置安全，请遵守操作指示；并于安全场所放置。

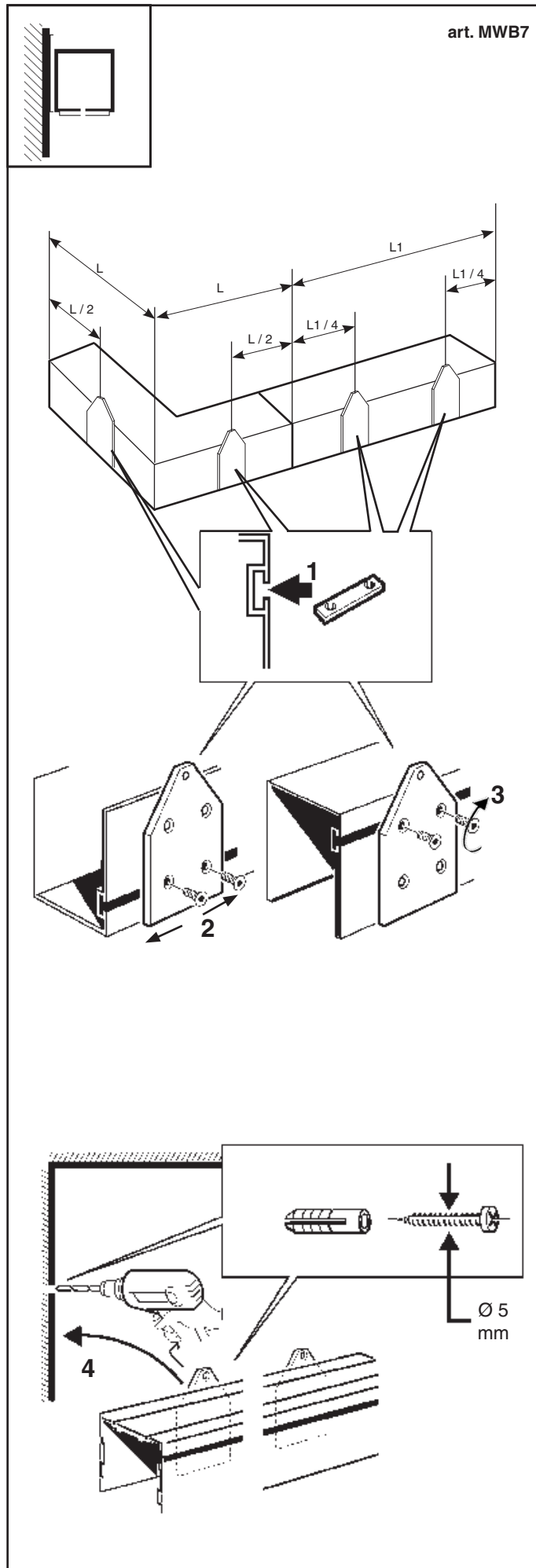
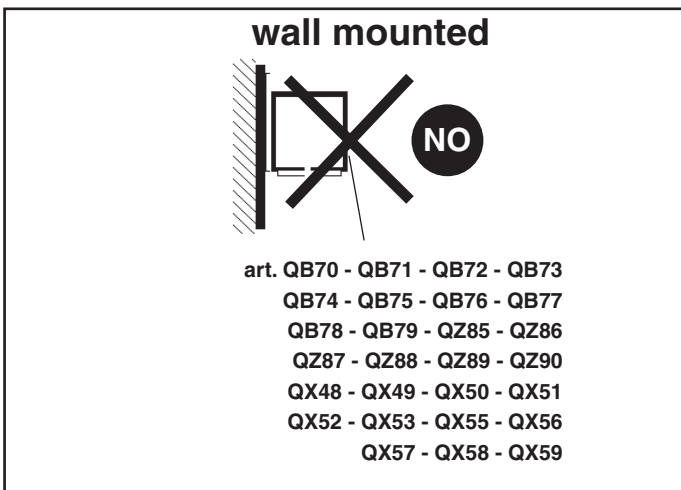
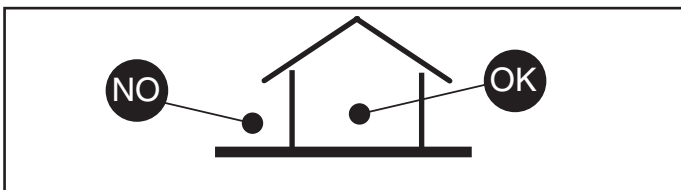

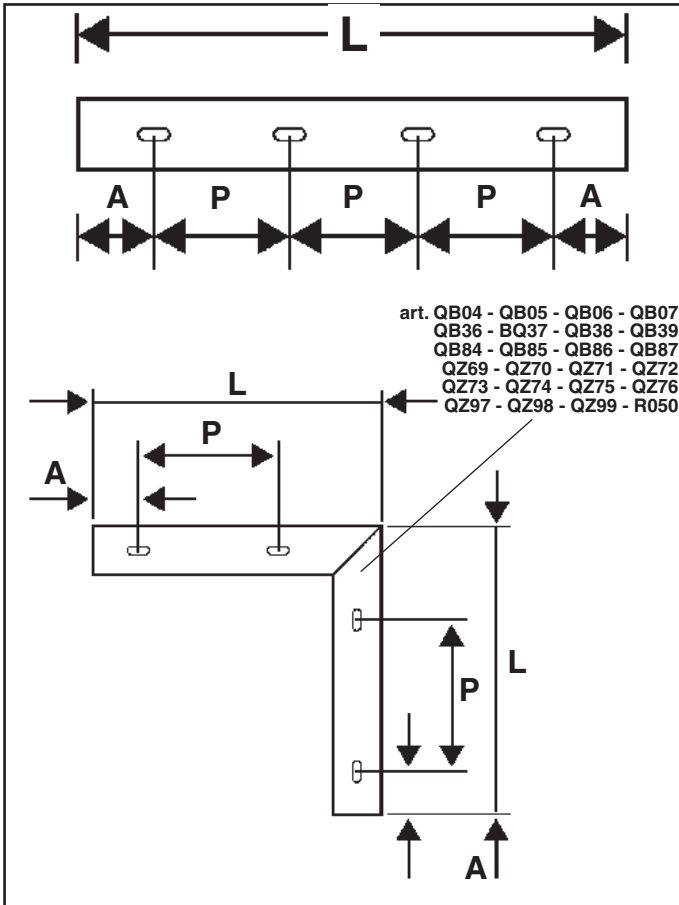
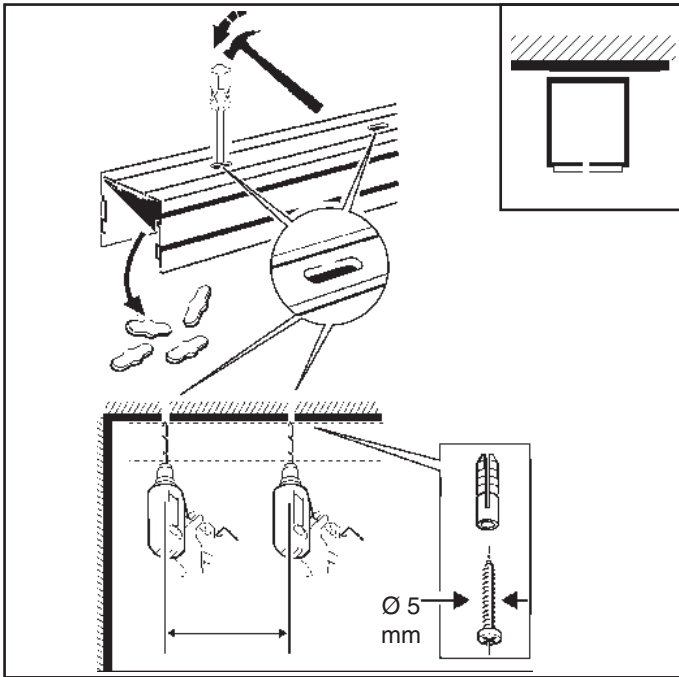

ART.	L (mm)	P (mm)	A (mm)
QA90 - QB70 - QZ57 - QZ85	612	250	140/222
QA91 - QB71 - QZ58 - QZ86	1208	500	354
QA92 - QB72 - QZ59 - QZ87	2397	800	398
QA93 - QB73 - QZ60 - QZ88	3596	1000	298
QA94 - QB74 - QZ61 - QZ89	898	500	199
QA95 - QB75 - QZ62 - QZ90	3596	1000	298
QB04 - QB05 - QB06 - QB07 QB36 - BQ37 - QB38 - QB39 QB84 - QB85 - QB86 - QB87 QZ69 - QZ70 - QZ71 - QZ72 QZ73 - QZ74 - QZ75 - QZ76 QZ97 - QZ98 - QZ99 - R050	642 x 642	250	180
QX48	1192	500	346
QX55	2384	800	392

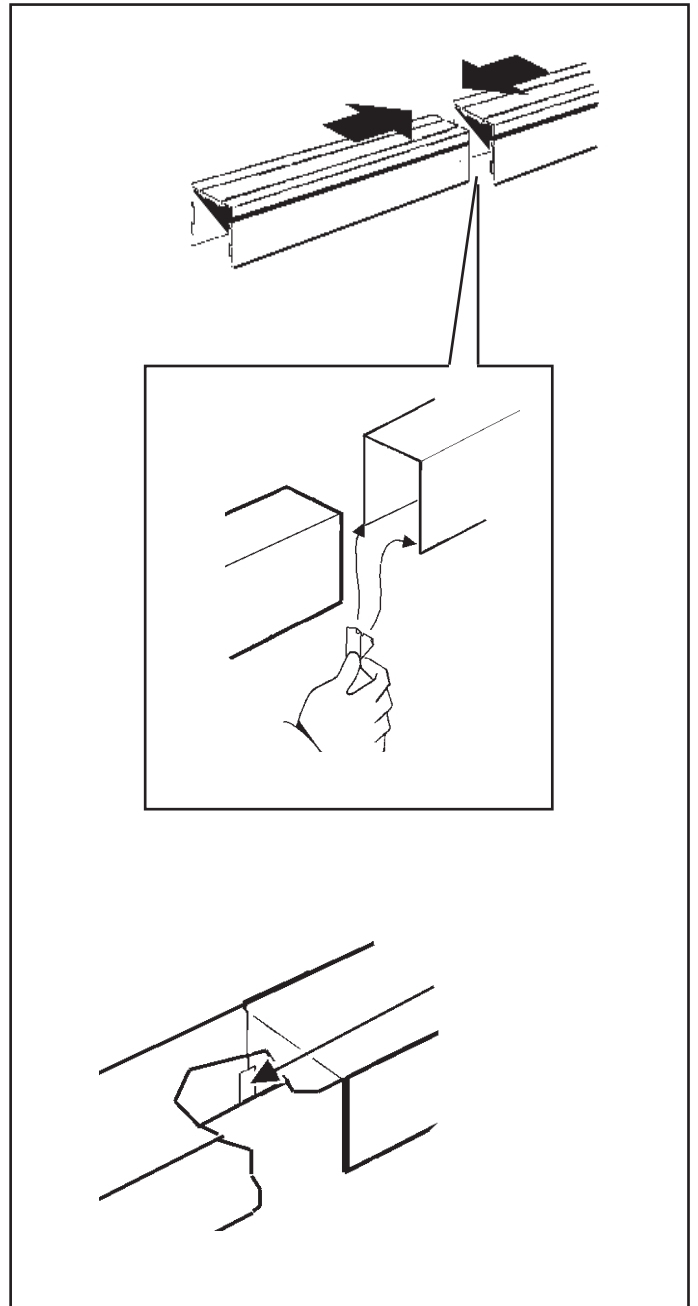

IT Per le posizioni di installazione, attenersi a quelle illustrate, eventualmente contattare la iGuzzini.

EN All installation positions must comply with those illustrated. In the event of any doubt, contact iGuzzini.

FR Pour les positions d'installation, se conformer aux positions illustrées ; contacter la société iGuzzini en cas de nécessité

DE Für die Einbaupositionen die Abbildungen beachten. Eventuell iGuzzini kontaktieren.

NL Houd u voor de installatieposities aan degene die zijn weergegeven. Neem eventueel contact op met iGuzzini

ES Respetar las posiciones de instalación ilustradas y, en caso de duda, contactar con iGuzzini

DA For installationspositioner skal man holde sig til de viste, og eventuelt kontakte iGuzzini

NO For installasjonsplassingene henviser vi til illustrasjonene, eller ta eventuelt kontakt med iGuzzini

SV Följ de angivna positionerna för installationen. Kontakta vid behov iGuzzini

RU При выборе положения для монтажа следует обратиться к проиллюстрированным либо обратиться в компанию iGuzzini

ZH 安装位置请参考图示, 必要时也可联系iGuzzini

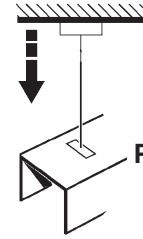

## IN60 Led (MINIMAL) Pendant Mounted

**IT Attenzione:**

La sicurezza dell'apparecchio e' garantita solo con l'uso appropriato delle seguenti istruzioni; pertanto e' necessario conservarle.

**EN Warning:**

The safety of this fixture is guaranteed only if you comply with these instructions; remember to conserve in a safe place.

**FR Attention:**

La sécurité de l'appareil n'est garantie qu'en cas d'utilisation correcte des instructions suivantes; il faut par conséquent les conserver.

**DE Achtung:**

Die sicherheit des gerätes wird nur durch sachgemässe befolgung nachstehender anweisungen gewährleistet; ihre aufbewahrung ist deshalb sehr wichtig.

**NL Opgelet:**

De veiligheid van di atoestel is slechts dan gegarandeerd als indien de volgende instructies strikt worden toegepast: daarom moet men ze ook bewaren.

**ES Atencion:**

La seguridad del aparato se garantiza solo cumpliendo cuidadosamente las siguientes instrucciones; por ello, es necesario conservarlas.

**DA Bemærk:**

Sikkerheden ved brug af armaturet kan kun garanteres, hvis disse anvisninger følges; sørg derfor for at gemme dem.

**NO Advarsel:**

Sikkerheten til dette apparatet garanteres kun hvis du overholder disse instruksjonene; husk å oppbevare dem på et trygt sted.

**SV Observera:**

Utrustningens säkerhet kan endast garanteras om dessa anvisningar respekteras i detalj. Spara därför dessa anvisningar för framtida konsultation.

**RU Внимание:**

Мы гарантируем безопасную эксплуатацию изделия только при соблюдении следующих инструкций; с этой целью необходимо сохранить данную брошюру.

**ZH 警告:**

为确保该装置安全，请遵守操作指示；并于安全场所放置。

AR

تحذير : لا يمكن ضمان سلامة هذا الجهاز إلا إذا التزمت بهذه التعليمات. يجب حفظها في مكان آمن.

Installazione a sospensione  
Suspension installation  
Installation en suspension  
Installation mit stahleilaufhängung  
Het ophangen  
Instalacion colgada  
Pendelnde ophæng  
Hengeinstallasjon  
Hängande installation  
ПОДВЕСНОЙ МОНТАЖ  
吊顶式安装

تركيب بالتعليق

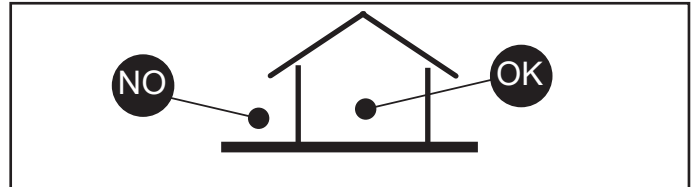

START

	General Lighting Version	UGR Version	MMO Version	Space Version
art. MWB4	✓	✓	✗	✗
MWM2 (DALI)	✓	✓	✓	✓
MWB5 (DALI Emergency)	✗	✗	✓	✓

	L START (mm)	P (mm)
2 x	612	512
	1208	1108
	2397	2297
	3596	3496
	1192	1092
	2384	2284



**MIDDLE/END**

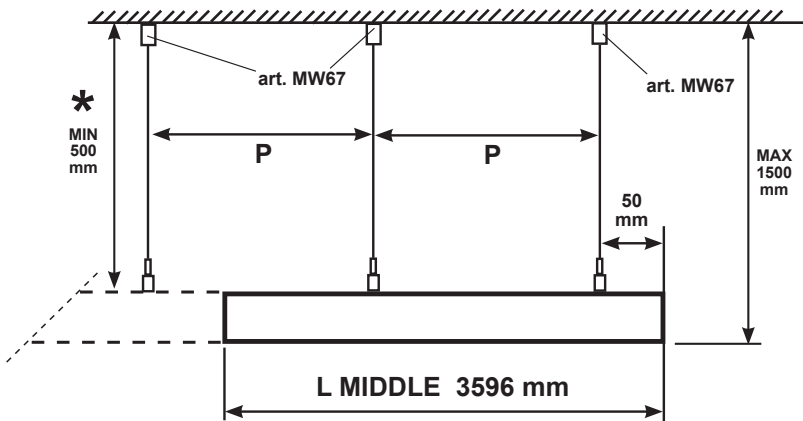
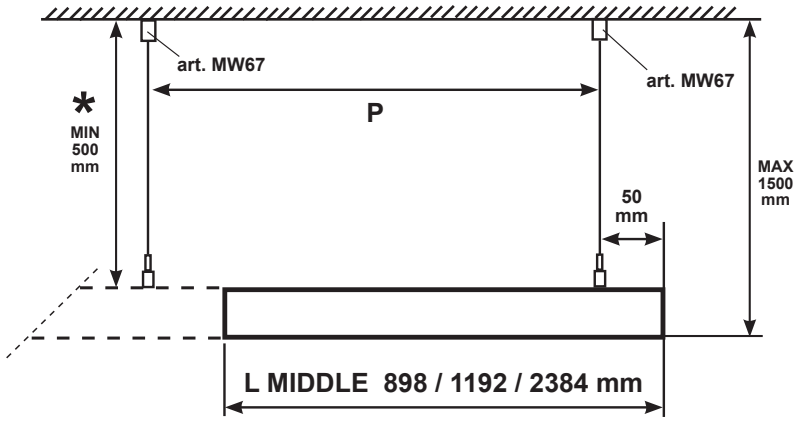
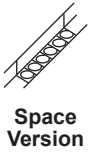

	L MIDDLE (mm)	P (mm)
1 x	898	898
	1192	1192
	2384	2384
2 x	3596	1798

\*

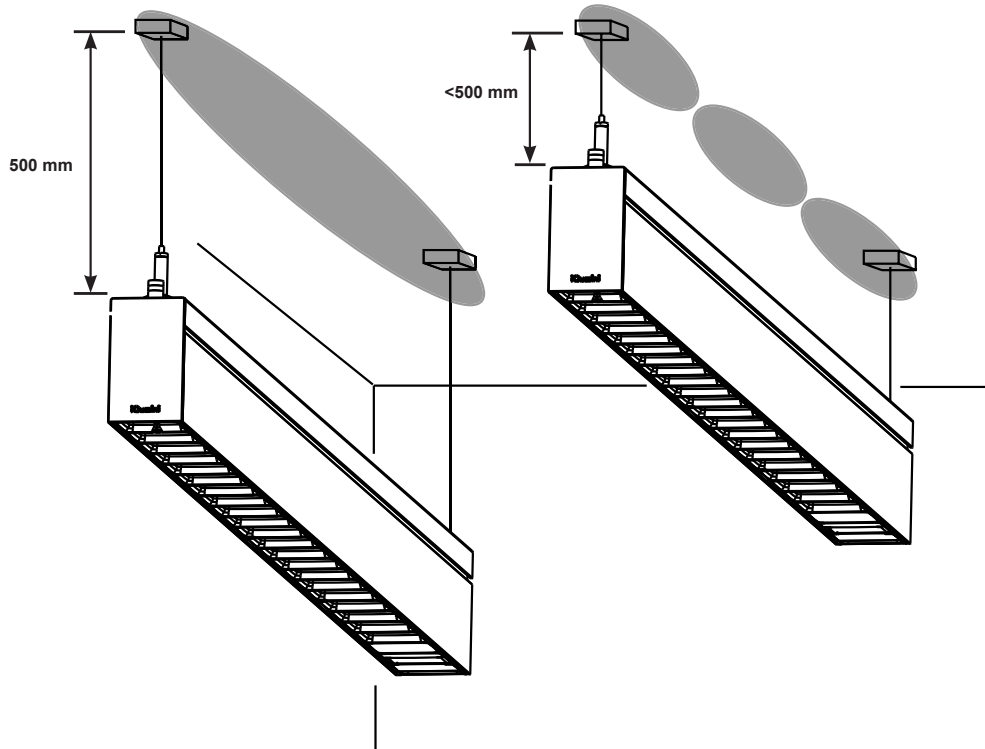

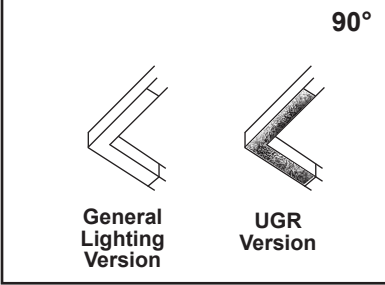
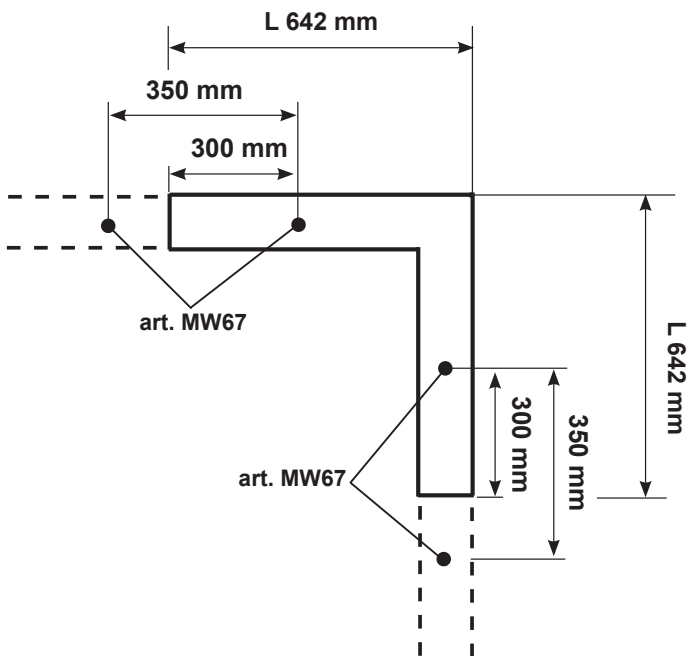

	<b>L (mm)</b>
2 x	642 x 642

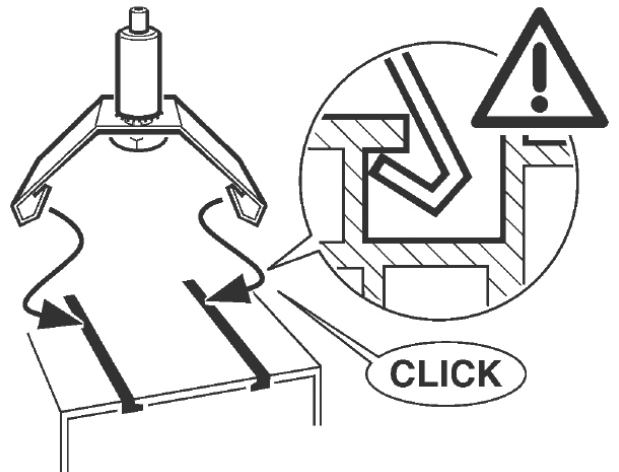
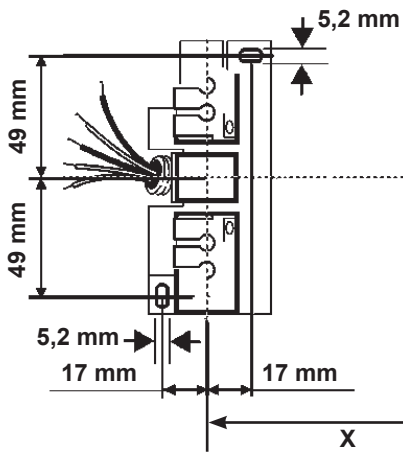
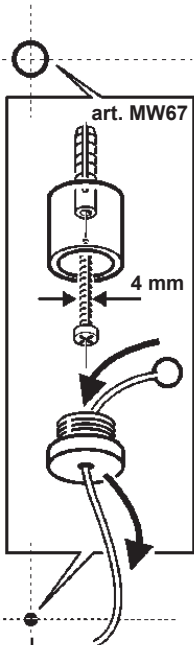
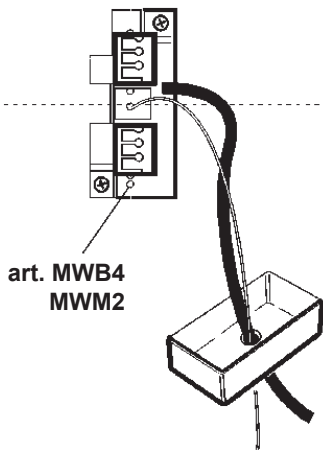
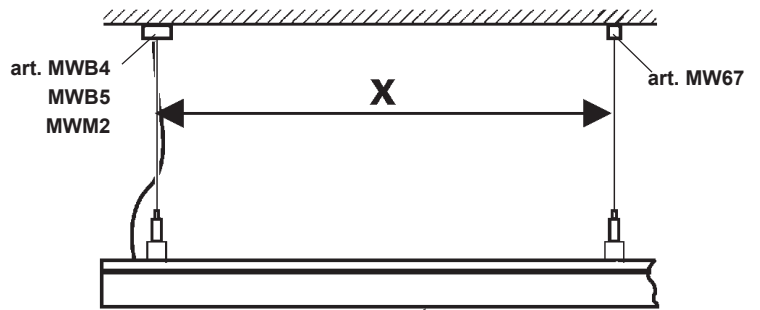
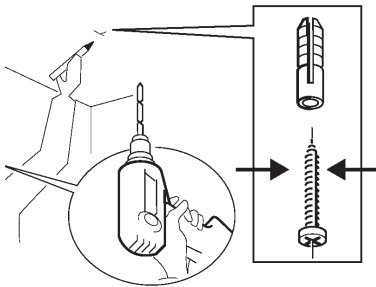

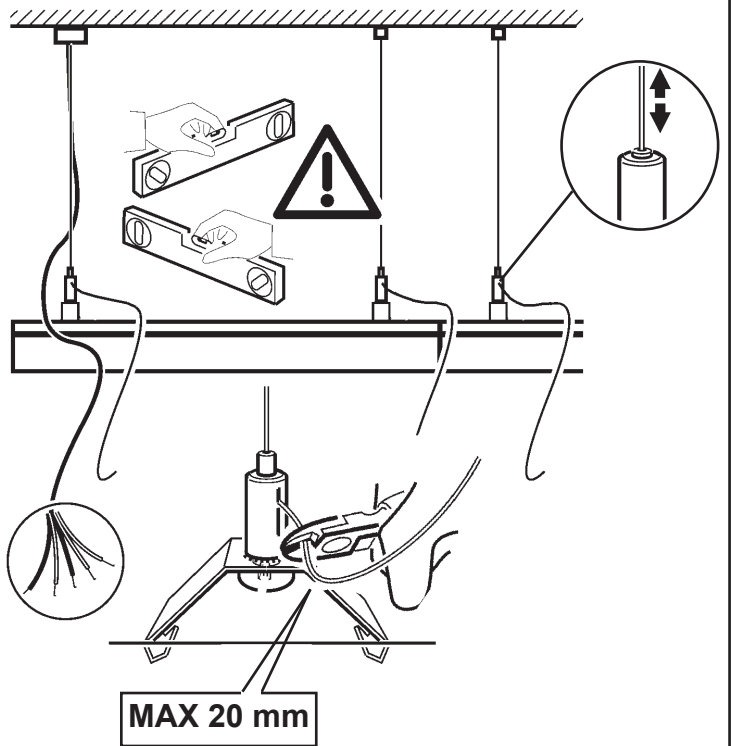
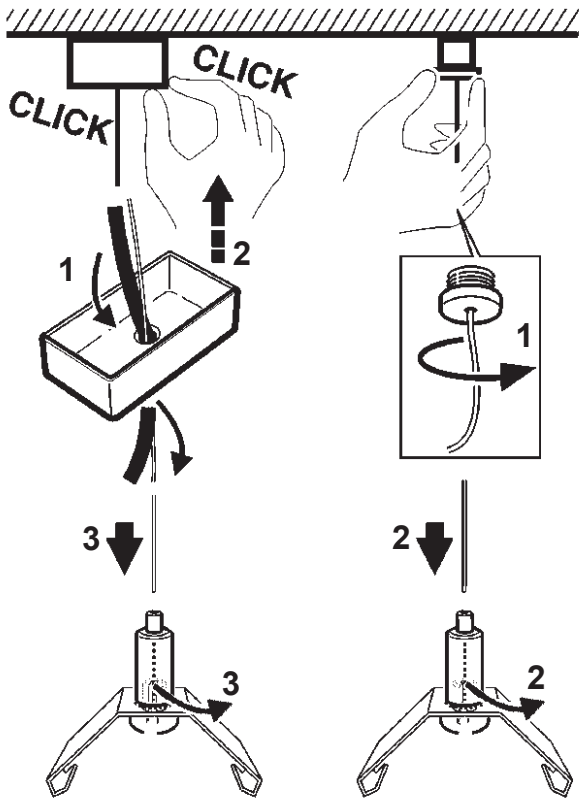
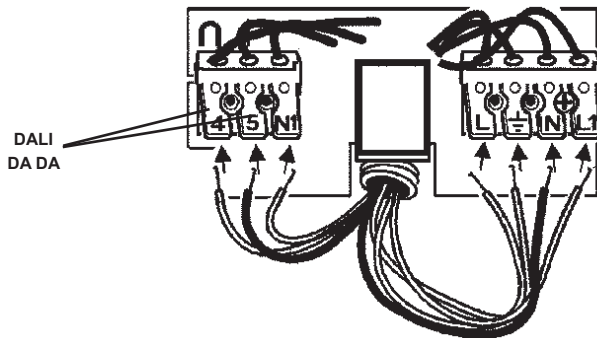
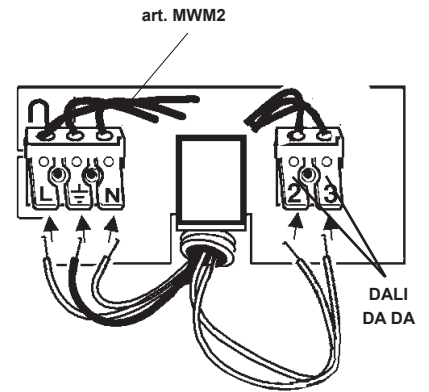
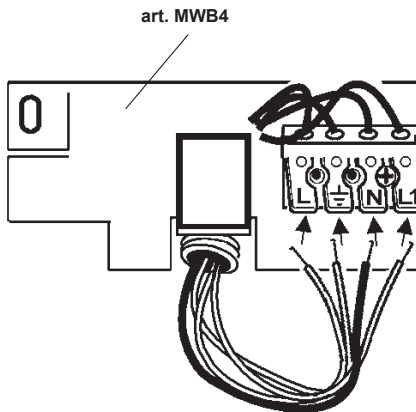
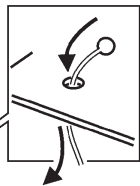
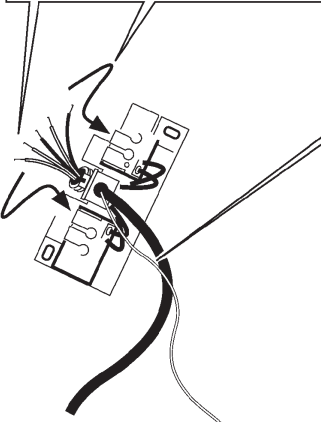
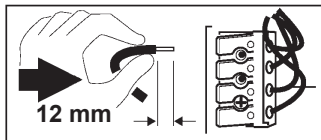
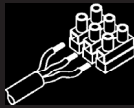

- IT N.B.: Per la sostituzione del LED contattare l'azienda iGuzzini.
- EN N.B.: For information on LED replacement please contact iGuzzini.
- FR N.B.: Pour procéder au remplacement de la LED, adressez-vous à la société iGuzzini.
- DE N.B.: Bezüglich des Austausches der LED kontaktieren Sie bitte die Firma iGuzzini.
- NL N.B.: Voor het vervangen van de LED neemt u contact op met het bedrijf iGuzzini.
- ES NOTA: Para sustituir el LED llame a la empresa iGuzzini.
- DA N.B.: For udskiftning af lysdioden, skal man kontakte iGuzzini.
- NO N.B.: For informasjon om skifte av LED, vennligst ta kontakt med iGuzzini.
- SV OBS! För byte av lysdioden, kontakta företaget iGuzzini.
- RU ПРИМЕЧАНИЕ: Для замены СИДов обращайтесь в компанию iGuzzini.
- ZH 注意: 如需LED更换的信息, 请联系iGuzzini

AR تنبيه: لاستبدال الضوء LED اتصل بشركة iGuzzini

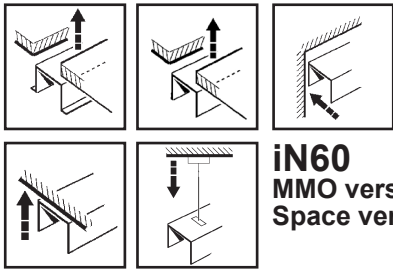

**IN60**  
MMO version  
Space version

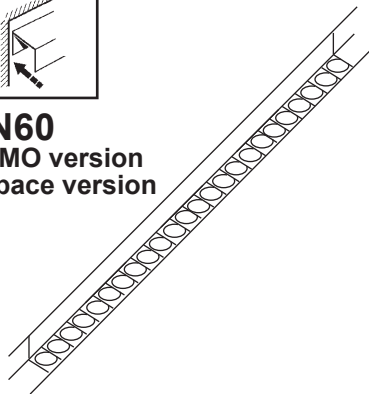

**IT ATTENZIONE:**

LA SICUREZZA DELL'APPARECCHIO E' GARANTITA SOLO CON L'USO APPROPRIATO DELLE SEGUENTI ISTRUZIONI; PERTANTO E' NECESSARIO CONSERVARLE.

**EN WARNING:**

THE SAFETY OF THIS FIXTURE IS GUARANTEED ONLY IF YOU COMPLY WITH THESE INSTRUCTIONS; REMEMBER TO CONSERVE IN A SAFE PLACE.

**FR ATTENTION:**

LA SECURITE DE L'APPAREIL N'EST GARANTIE QU'EN CAS D'UTILISATION CORRECTE DES INSTRUCTIONS SUIVANTES; IL FAUT PAR CONSEQUENT LES CONSERVER.

**DE ACHTUNG:**

DIE SICHERHEIT DES GERÄTES WIRD NUR DURCH SACHGEMÄSSE BEFOLGUNG NACHSTEHENDER ANWEISUNGEN GEWÄHRLEISTET; IHRE AUFBEWAHRUNG IST DESHALB SEHR WICHTIG.

**NL OPGELET:**

DE VEILIGHEID VAN DI ATOESTEL IS SLECHTS DAN GEGARANDEERD ALS INDIEN DE VOLGENDE INSTRUCITIES STRIKT WORDEN TOEGEPAST: DAAROM MOET MEN ZE OOK BEWAREN.

**ES ATENCION:**

LA SEGURIDAD DEL APARATO SE GARANTIZA SOLO CUMPLIENDO CUIDADOSAMENTE LAS SIGUIENTES INSTRUCCIONES; POR ELLO, ES NECESARIO CONSERVARLAS.

**DA BEMÆRK:**

SIKKERHEDEN VED BRUG AF ARMATURET KAN KUN GARANTERES, HVIS DISSE ANVISNINGER FØLGES; SØRG DERFOR FOR AT GEMME DEM.

**NO ADVARSEL:**

SIKKERHETEN TIL DETTE APPARATET GARANTERES KUN HVIS DU OVERHOLDER DISSE INSTRUKSJONENE; HUSK Å OPPBEVARE DEM PÅ ET TRYGT STED.

**SV OBSERVERA!**

UTRUSTNINGENS SÄKERHET KAN ENDAST GARANTERAS OM DESSA ANVISNINGAR RESPEKTERAS I DETALJ. SPARA DÄRFÖR DESSA ANVISNINGAR FÖR FRAMTIDA KONSULTATION.

**RU ВНИМАНИЕ:**

МЫ ГАРАНТИРУЕМ БЕЗОПАСНУЮ ЭКСПЛУАТАЦИЮ ИЗДЕЛИЯ ТОЛЬКО ПРИ СОБЛЮДЕНИИ СЛЕДУЮЩИХ ИНСТРУКЦИЙ; С ЭТОЙ ЦЕЛЬЮ НЕОБХОДИМО СОХРАНИТЬ ДАННУЮ БРОШЮРУ.

**ZH 警告**

为确保该装置安全，请遵守操作指示；并于安全场所放置。

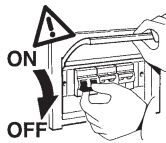

**IT** N.B.: DURANTE L'INSTALLAZIONE DEL SISTEMA "IN 60 LED" RISPETTARE SCRUPOLOSAMENTE LE NORME IMPIANTISTICHE NAZIONALI VIGENTI.

**EN** N.B.: WHEN INSTALLING THE "IN 60 LED" SYSTEM, MAKE SURE ALL CURRENT NATIONAL REGULATIONS RELATING TO INSTALLATION ARE OBSERVED.

**FR** N.B.: LORS DE L'INSTALLATION DU SYSTÈME "IN 60 LED" VEUILLEZ RESPECTER RIGOREUSEMENT LES NORMES EN VIGUEUR EN LA MATIÈRE DANS LE PAYS.

**DE** N.B.: BEACHTEN SIE BEI DER INSTALLATION DES SYSTEMS "IN 60 LED" UNBEDINGT DIE IM LAND GELTENDEN ANLAGETECHNISCHEN VORSCHRIFTEN.

**NL** N.B.: BIJ HET INSTALLEREN VAN HET "IN 60 LED" SYSTEEM MOET U DE GELDENDE NATIONALE INSTALLATIENORMEN STRIKT NALEVEN.

**ES** NOTA: DURANTE LA INSTALACIÓN DEL SISTEMA "IN 60 LED" RESPETAR ESCRUPULOSAMENTE LAS NORMAS NACIONALES DE INSTALACIÓN EN VIGOR.

**DA** N.B.: UNDER INSTALLATION AF "IN 60 LED" SYSTEMET SKAL MAN NØJE OVERHOLDE DE GÆLDENDE REGLER FOR DISSE ANLÆG.

**NO** N.B.: UNDER INSTALLASJON AV SYSTEMET "IN 60 LED" MÅ DE NASJONALE ANLEGGSFORSKRIFTENE OVERHOLDES NØYE.

**SV** OBS! UNDER INSTALLATIONEN AV SYSTEMET "IN 60 LED" SKAGÄLLANDE NATIONELLA INSTALLATIONSFÖRESKRIFTER RESPEKTERAS I DETALJ.

**RU** ПРИМЕЧАНИЕ: В ПРОЦЕССЕ МОНТАЖА СИСТЕМЫ "IN 60 LED" СТРОГО СОБЛЮДАЙТЕ НАЦИОНАЛЬНЫЕ ДЕЙСТВУЮЩИЕ НОРМАТИВЫ ПО ЭЛЕКТРОПРОВОДКЕ.

**ZH** 重要：安装 "IN 60 LED" 系统时请始终参照标准系统

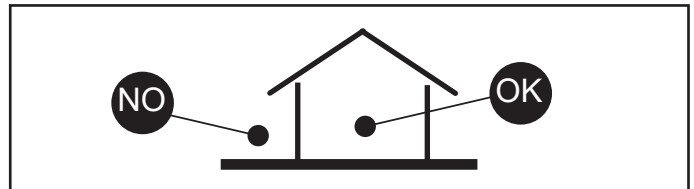

**IT** INSTALLAZIONE SUL CONTROSOFFITTO  
**EN** INSTALLATION ON CEILING  
**FR** INSTALLATION AU FAUX-PLAFOND  
**DE** INSTALLATION AN DER HÄNGEDECKE  
**NL** HET INSTALLEREN IN HET VERLAAGDE PLAFOND  
**ES** INSTALACION SOBRE FALSO TECHO  
**DA** INSTALLATION PÅ FORSÆNKET LOFT  
**NO** MONTERING I TAKET  
**SV** INSTALLATION I UNDERTAK  
**RU** МОНТАЖ В ФАЛЬШ-ПОТОЛКЕ  
**ZH** 吸顶式安装天花板上的安装

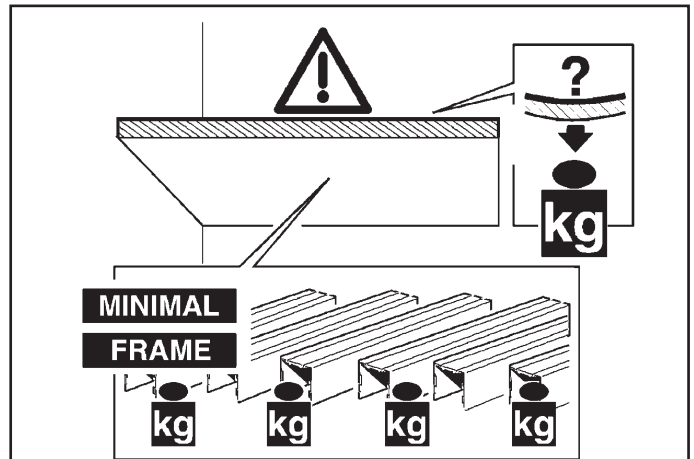

**IT** N.B.: E' responsabilità dell'utente verificare la resistenza del controsoffitto, in funzione del peso degli apparecchi installati.

**EN** N.B.: It is the user's responsibility to check the strength of the false ceiling with respect to the weight of the fixtures installed.

**FR** N.B.: Il appartient à l'utilisateur de vérifier la résistance du faux plafond en fonction du poids des appareils installés.

**DE** N.B.: Es obliegt dem Verbraucher sicherzustellen, daß die Deckenverkleidung das Gewicht der Einbauleuchte aufnehmen kann.

**NL** N.B.: Het is de verantwoordelijkheid van de koper zich ervan te verzekeren dat het verlaagde plafond stevig genoeg is voor het dragen van het gewicht van de geïnstalleerde apparaten.

**ES** NOTA: Corresponde al usuario efectuar las pruebas en el falso techo, en función del peso de los aparatos instalados.

**DA** N.B.: Det er brugerens ansvar, at kontrollere loftets modstanddygtighed, ud fra de installerede apparaters vægt.

**NO** N.B.: Det er brukerens ansvar å kontrollere himlingens/takets motstandskraft, på grunnlag av de installerte apparatens vekt.

**SV** OBS! Det är användarens ansvar att kontrollera takets hållfasthet i förhållande till vikten på installerad utrustning.

**RU** ПРИМЕЧАНИЕ: Пользователь должен проверить прочность фальш-потолка в соответствии с весом устанавливаемых в него приборов.

**ZH** 注意：用户须根据安装装置的重量 检查天花板的强度。



**IT** N.B.: Apparecchi non idonei ad essere coperti di materiale termicamente isolante

**EN** N.B.: Fixtures not suitable to be covered in thermally-insulating material.

**FR** N.B.: Appareils ne pouvant pas être couverts de matériau d'isolation thermique

**DE** N.B.: Geräte nicht geeignet, um mit wärmeisolierendem Material abgedeckt zu werden

**NL** N.B.: Deze apparaten zijn niet geschikt om te worden bedekt met thermisch isolerend materiaal

**ES** NOTA: Aparatos no aptos para ser cubiertos de material térmicamente aislante

**DA** N.B.: Armaturerne må ikke dækkes af varmeisolerende materiale.

**NO** N.B.: Apparaten passer ikke til å dækkes av termoisolerende materialer.



**SV** OBS! Utrustningen får inte täckas över med värmeisolerande material

**RU** Внимание: Приборы непригодны для покрытия термоизоляционным материалом.

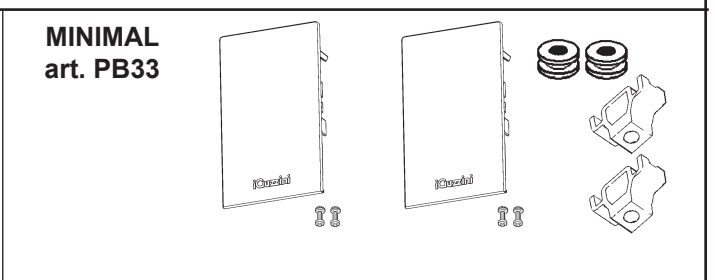
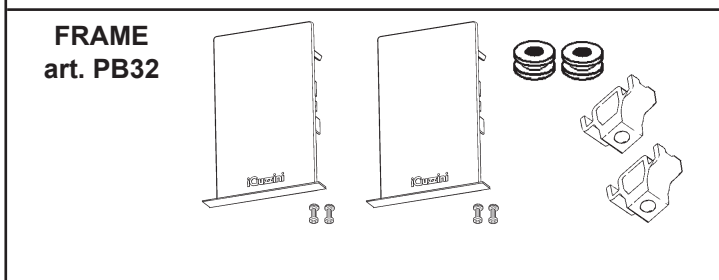
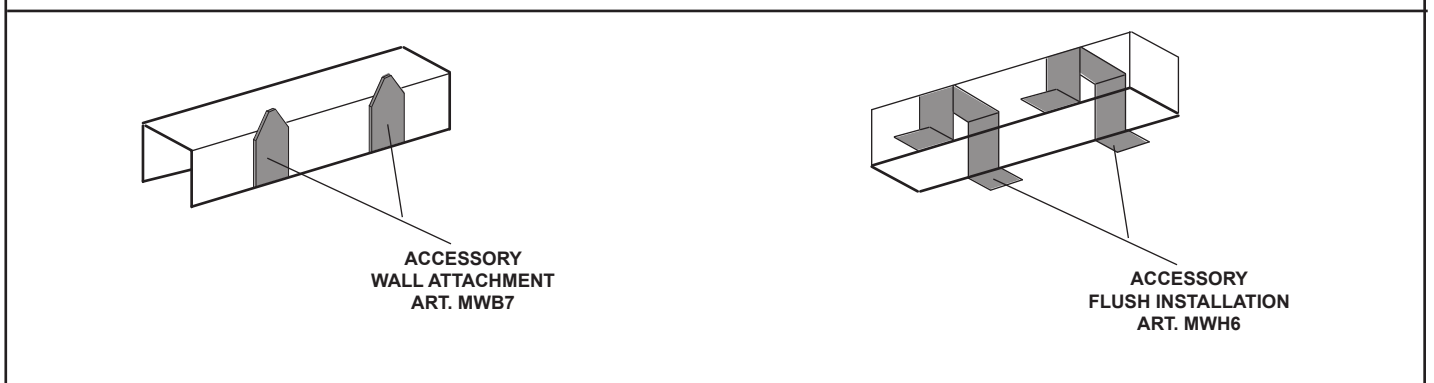
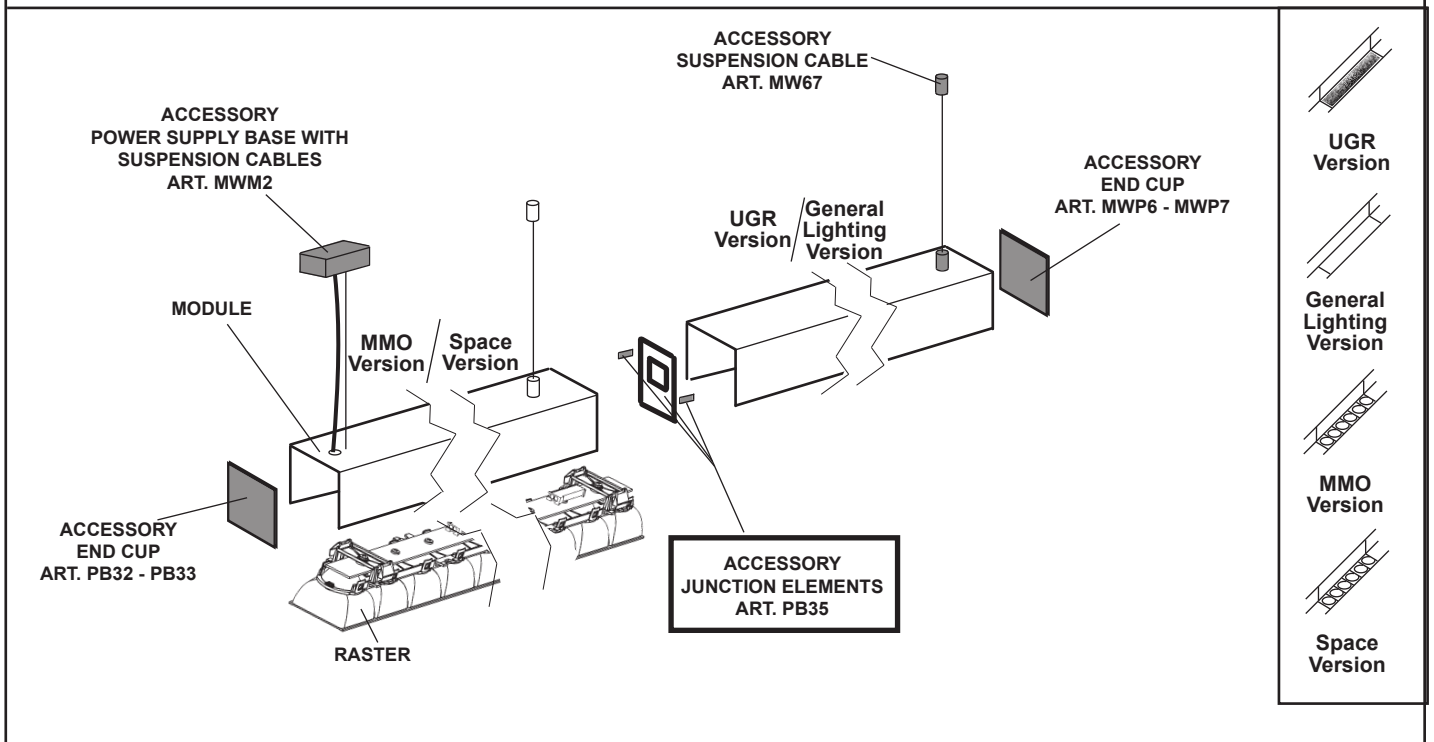
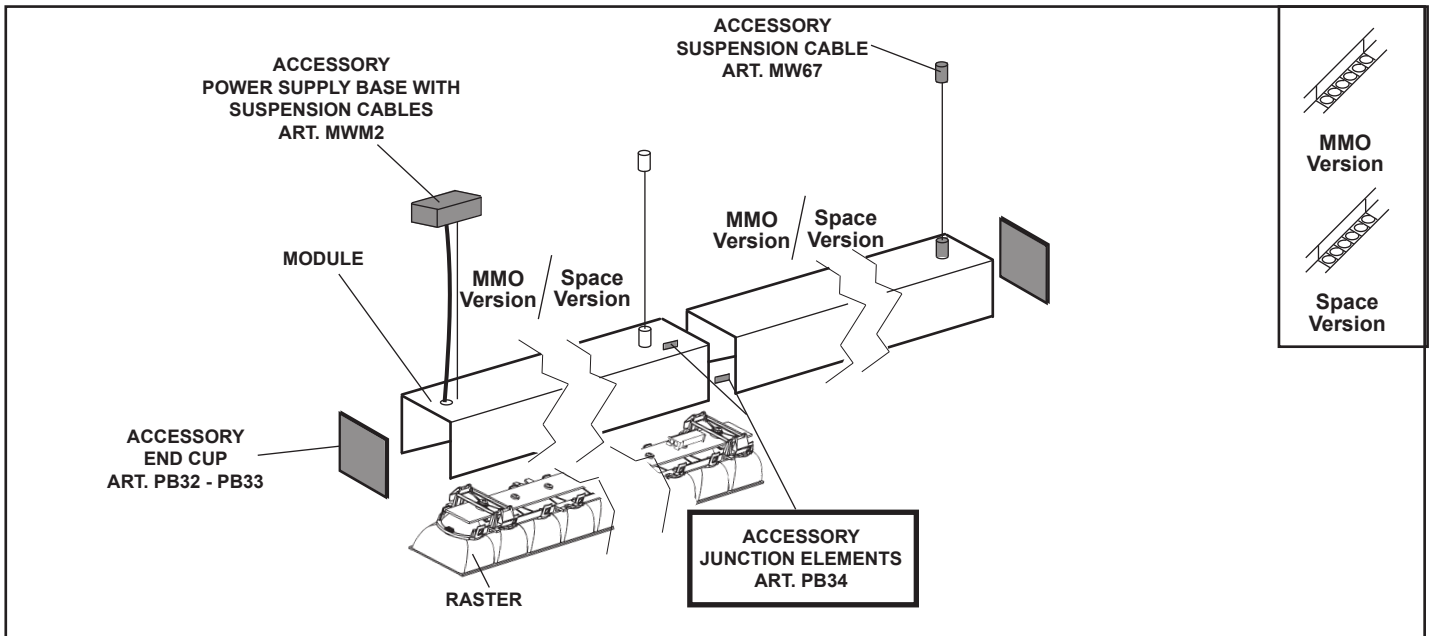

**ZH** 灯具不适用隔热材料加以覆盖。



# DOWN

L (mm)	MODULE 	RASTER 
1192	QX47 - QX48	QX89 - QX90 - QX91 - QX92 - QX93 - QX94 - QX95 - QX96 - QX97 - QX98 - QX99 - QY00 - QY01 - QY02 - QY03 - QY04 R526 - R527 - R528 - R529 - R530 - R531 - R532 - R533 - R534 - R535 - R536 - R537 - R538 - R539 - R540 - R541
2384	QX54 - QX55	QY18 - QY19 - QY20 - QY21 - QY22 - QY23 - QY24 - QY25 R555 - R556 - R557 - R558 - R559 - R560 - R561 - R562

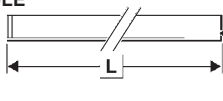
# UP/ DOWN

L (mm)	MODULE 	RASTER 
1192	QX49 - QX50 - QX51 - QX52 QX53	QY05 - QY06 - QY07 - QY08 - QY09 - QY10 - QY11 - QY12 - QY14 - QY15 - QY16 - QY17 R542 - R543 - R544 - R545 - R546 - R547 - R548 - R549 - R551 - R552 - R553 - R554 QY13 - R550
2384	QX56 - QX57 - QX58 - QX59	QY26 - QY27 - QY28 - QY29 - QY30 - QY31 - QY32 - QY33 - QY34 - QY35 - QY36 - QY37 R563 - R564 - R565 - R566 - R567 - R568 - R569 - R570 - R571 - R572 - R573 - R574

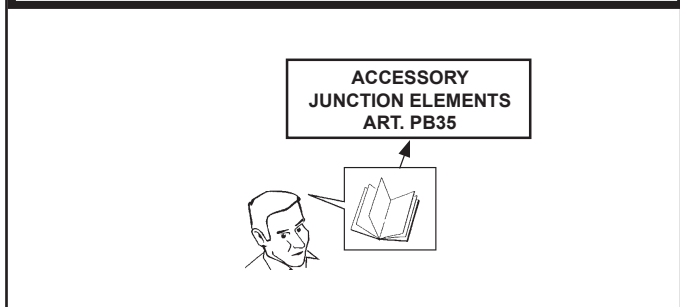
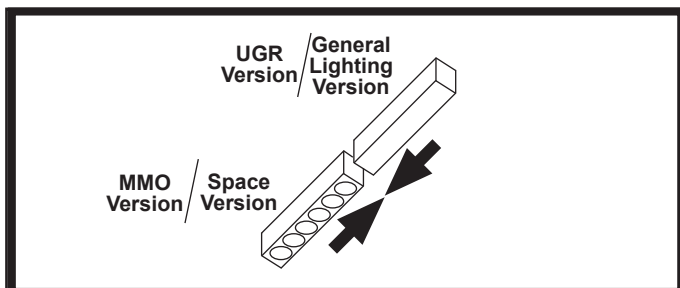
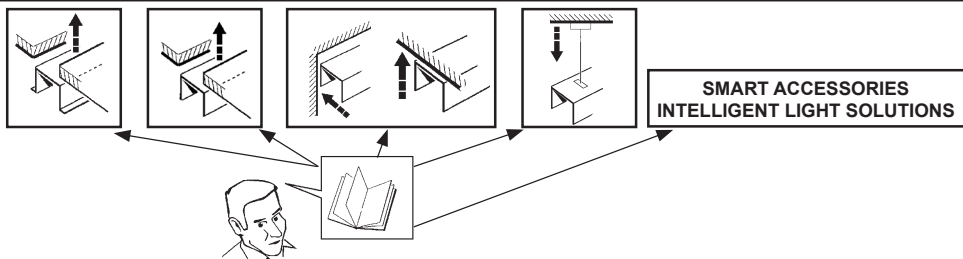

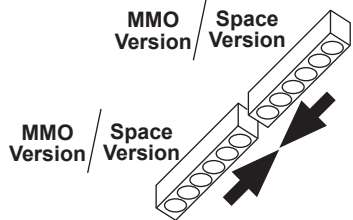

art. PB34

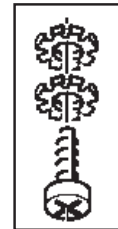
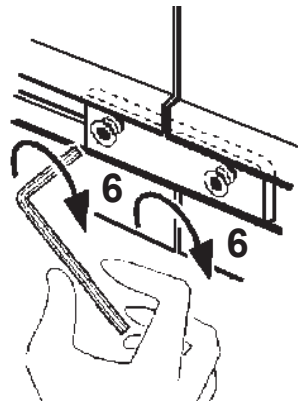
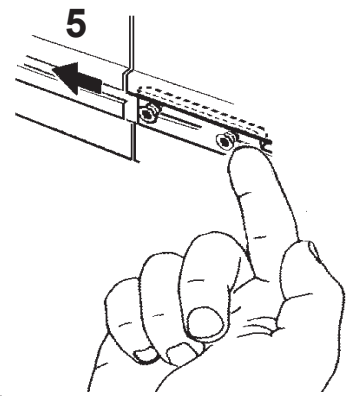
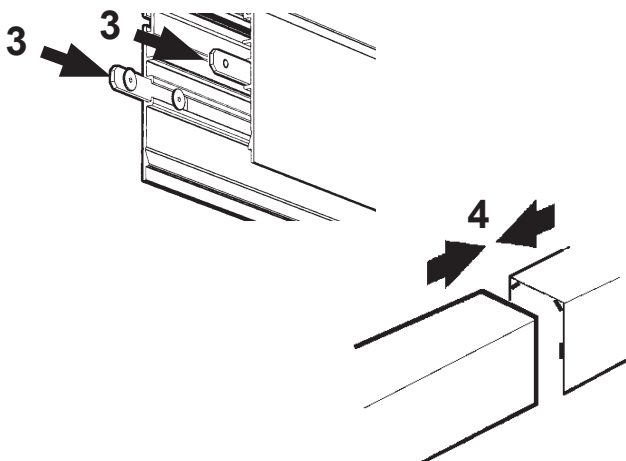
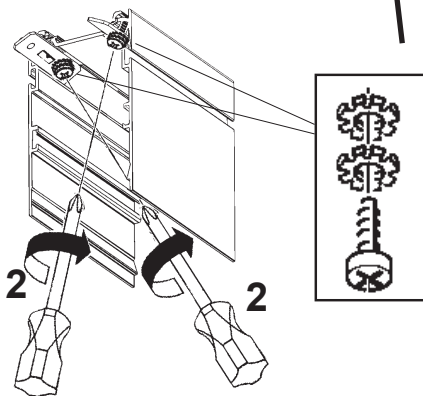
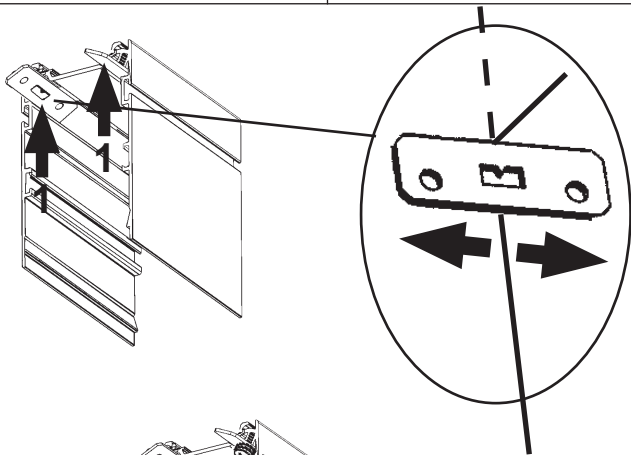
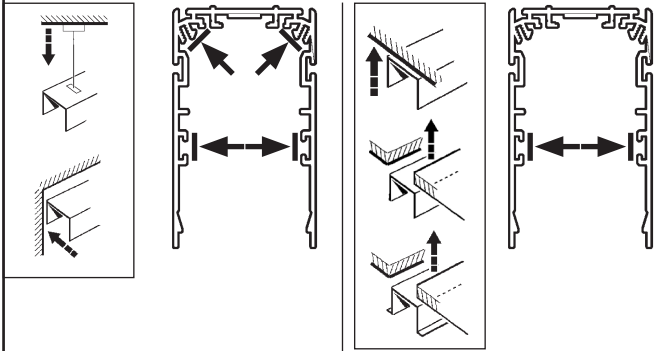

2x 7

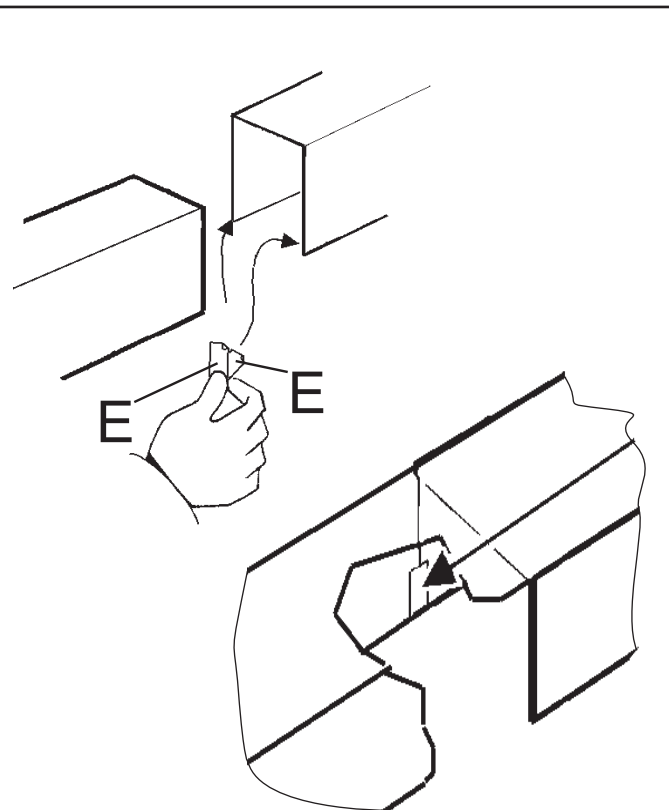

IT Applicare l'etichetta "E" come mostrato in figura.

EN Apply label "E" as shown in the figure.

FR Appliquez l'étiquette "E" comme illustré (voir figure).

DE Bringen Sie das Etikett "E" wie in der Abbildung dargestellt an.

NL Bevestig het etiket "E" zoals aangegeven in de figuur.

ES Aplicar la etiqueta "E" según ilustrado en la figura.

DA Sæt mærkatet "E" på, som vist i figuren.

NO Innrett merke "E" slik som vist på figuren.

SV Applicera etiketten "E" enligt figuren.

RU Нанесите этикетку «E», как показано на схеме.

ZH 按表中所示贴上标签"E"。

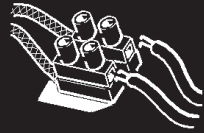

**IT** DETERMINAZIONE DELLE CORRENTI MASSIME AMMISSIBILI  
**EN** DETERMINING THE MAXIMUM PERMITTED CURRENT  
**FR** DETERMINATION DES COURANTS MAXIMAUX ADMISSIBLES  
**DE** BESTIMMUNG DER ZULÄSSIGEN HÖCHSTSTRÖME  
**NL** VASTSTELLEN VAN DE MAXIMAAAL TOEGESTANE STROOMTOEVOER  
**ES** DETERMINACIÓN DE LAS CORRIENTES MÁXIMAS PERMITIDAS  
**DA** BESTEMMELSE AF MAKS. TILLADT STRØMSTYRKE  
**NO** BESTEMME MAKSIMAL TILLATT STRØM  
**SV** FASTSTÄLLANDE MAX. TILLÅTEN STRÖM  
**RU** ОПРЕДЕЛЕНИЕ МАКСИМАЛЬНОГО ДОПУСТИМОГО ТОКА  
**ZH** 确定最大通过电流

**IT** Nella progettazione dell'impianto illuminotecnico ed elettrico, determinare le correnti massime ammissibili, considerando i seguenti fattori:  
 - 9A corrente nominale ammessa dai morsetti  
 - coefficiente di sicurezza per tenere conto delle sovratensioni e contemporaneità;  
 - corrente nominale assorbita dai singoli moduli (vedi tabella)

**EN** When planning the lighting and electrical system, determine the maximum permitted current taking into account the following factors:  
 - 9A the nominal current permitted by terminal block  
 - safety coefficient to allow for excess voltage and contemporaneity  
 - the nominal current absorbed by single modules (see table)

**FR** Lors de l'étude de projet de l'installation d'éclairage et de l'installation électrique, déterminer les courants maximaux admissibles en tenant compte des facteurs suivants :  
 - 9A courant maximal admis par le bornier  
 - coefficient de sécurité tenant compte des surtensions et de la simultanéité;  
 - courant nominal absorbé par les différents modules (voir tableau)

**DE** Bei der Planung einer Beleuchtungs- und Elektroanlage bestimmen Sie die zulässigen Höchstströme unter Berücksichtigung folgender Faktoren:  
 - 9A von den Klemmleiste zugelassener Nennstrom  
 - Sicherheitskoeffizient zur Einbeziehung von Überspannung und Gleichzeitigkeit;  
 - von den einzelnen Modulen aufgenommener Nennstrom (siehe Tabelle)

**NL** Bij het ontwerpen van de verlichtingstechnische en elektrische installatie moet u de maximaal toegestane stroomtoevoer vaststellen door rekening te houden met de volgende factoren:  
 - 9A nominale stroom toegestaan op klemmenstroken  
 - veiligheidscoëfficiënt om rekening te houden met overspanning en gelijktijdigheid;  
 - nominale opgenomen stroom van de enkele modules (zie tabel)

**ES** Durante la proyección de la instalación luminotécnica y eléctrica, determinar las corrientes máximas permitidas, en consideración de los factores siguientes:  
 - 9A corriente nominal permitida de la bornera  
 - coeficiente de seguridad para considerar sobretensiones y contemporaneidades  
 - corriente nominal absorbida por los módulos individuales (ver tabla)

**DA** I projekteringen af det belysnings-tekniske og elektriske anlæg, skal man undersøge den maks. tilladte strømstyrke, idet man tager højde for følgende:  
 - 9A den nominelle, tilladte strømstyrke fra klæmkerne  
 - sikkerhedsfaktor for at sikre mod overspænding og samtidighedsfaktor  
 - absorberet nominal strømstyrke på de enkelte moduler (se tabellen).

**NO** Ved planlegging av lys- og elektrisk system, bestem maksimalt tillatt strøm, ta med betraktningen følgende faktorer:  
 - 9A nominell strøm tillatt av terminalblokkene  
 - sikkerhetskoeffisiens for å tillate overflødig spenning og aktualitet,  
 - nominell strøm absorbert av enkeltmoduler (se tabel)

**SV** Vid projekteringen av belysnings-systemet och det elektriska systemet ska max. tillåten ström fastställas. Ta hänsyn till följande faktorer:  
 - 9A Tillåten nominell ström från kopplingsplintarna  
 - Säkerhetskoefficient för att ta hänsyn till överspänningar och sammanlagringar  
 - Tillförd nominell ström från enskilda moduler (se tabell).

**RU** При расчёте светотехнической системы и электропроводки определите максимальный допустимый ток с учетом следующих факторов:  
 - 9A номинальный допустимый ток на клеммных колодках  
 - коэффициент безопасности для учета перенапряжения и одновременного включения различных приборов;  
 - номинальный ток, поглощаемый отдельными модулями (см. таблицу)

**ZH** 规划照明和电路系统时，确定最大允许电流，并考虑下列因素：  
 - 9A 接线排 允许的正常电流  
 - 允许超过规定电压和同时性的安全系数；  
 - 为单个模块使用的常规电流（见表）

**I** Tra i conduttori di alimentazione e quelli di controllo è garantito un isolamento fondamentale.

**EN** Insulation is guaranteed between the power supply wires and the control wires basic.

**FR** Entre les conducteurs d'alimentation et les conducteurs de commande, une isolation est garantie fondamentale.

**DE** Zwischen den Versorgungs- und Steuerungsleitern ist eine Isolierung Basis gewährleistet.

**NL** Tussen de geleiders van de voeding en de controle wordt een isolatie gewaarborgd fundamenteel.

**ES** Entre los conductores de alimentación y los de control está garantizado el aislamiento fundamental.

**DA** Der er garanteret en isolering grundlæggende imellem forsyningslederne og styrelederne.

**NO** Det garanteres en isolering fundamental mellom strømlederne og kontrolllederne.

**SV** Det garanteras isolering grundläggande mellan matningsledare och kontrollkablar.

**RU** Гарантируется развязка цепей питания и управления фундаментальная.

**ZH** 电源线和控制线之间有绝缘保证基本。

ART.	CARICO DALI / DALI LOAD CHARGE DALI (COURANT MAXI ADMISSIBLE) DALI-LAST DALI VERMOGEN CARGA DALI DALI STRØMSTYRKE BELASTNING FOR "DALI" DALI-BELASTNING МАКС. ТОК СИСТЕМЫ DALI С РЕГУЛЯЦИЕЙ ИНТЕНСИВНОСТИ СВЕТА DALI 智能调光系统允许的最大电流量	INDIRIZZI DALI DALI ADDRESSES ADRESSES DALI DALI-ADRESSEN DALI ADRESSEN DIRECCIONES DALI DALI ADDRESSER ADRESSER TIL "DALI" DALI-ADRESSER ЛОГИЧЕСКИЕ АДРЕСА СИСТЕМЫ DALI DALI 智能调光系统计算机指 定控制参数	PROTOCOLLO DALI DEVICE TYPE
QX89 - QX90 - QX91 - QX92 - QX93 - QX94 QX95 - QX96 - QY05 - QY06 - QY07 - QY08 QY09 - QY10 - QY11 - QY12 - QY18 - QY19 QY20 - QY21 - QY22 - QY23 - QY24 - QY25 QY26 - QY28 - QY30 - QY32 - R526 - R527 R528 - R529 - R530 - R531 - R532 - R533 R542 - R543 - R544 - R545 - R546 - R547 R548 - R549 - R555 - R556 - R557 - R558 R559 - R560 - R561 - R562 - R563 - R565 R567 - R569	1 (2 mA)	1	DT6
QY14 - QY15 - QY16 - QY17 QY34 - QY35 - QY36 - QY37 R551 - R552 - R553 - R554 R571 - R572 - R573 - R574		2	DT6
QY13 - R550		1	DT8
QY27 - QY29 - QY31 - QY33 R564 - R566 - R568 - R570	2 (4 mA)	2	DT6

### MINIMAL DOWN

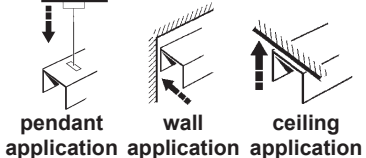

### FRAME MINIMAL

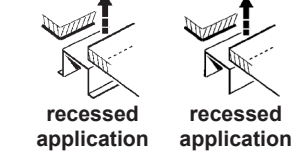

**1A** Hammer and screwdriver icon.

**2A** Cable bundle icon.

**3A** Cable bundle icon with dimensions: 70 mm, 10 mm, MIN 6mm, MAX 12mm.

**4A** Cable bundle icon.

**5A** Cable bundle icon.

ALIMENTAZIONE POWER SUPPLY ALIMENTATION EINSPEISUNG STROOMVERZORGING ALIMENTACION STRØMFORSYNING STRØMFORSYNING ELFÖRSÖRJNING ЭЛЕКТРОПИТАНИЕ 电源

90° OK



# MINIMAL UP/DOWN

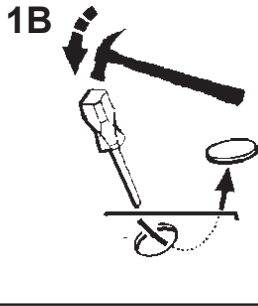
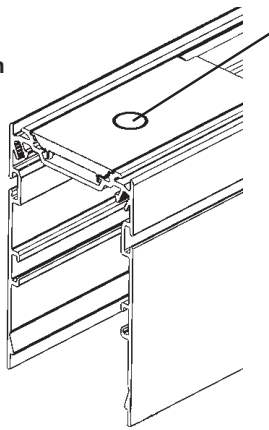
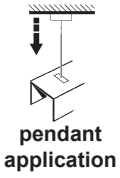

ALIMENTAZIONE  
POWER SUPPLY  
ALIMENTATION  
EINSPEISUNG  
STROOMVERZORGING  
ALIMENTACION  
STRØMFORSYNING  
STRØMFORSYNING  
ELFORSØRNING  
ЭЛЕКТРОПИТАНИЕ  
电源

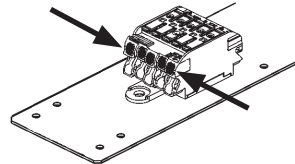
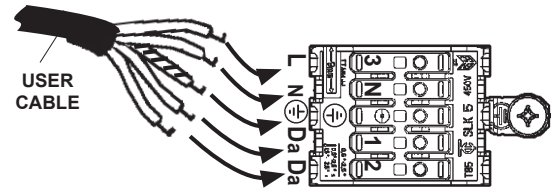
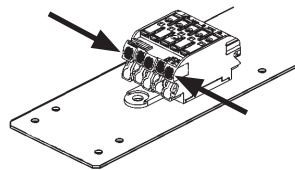
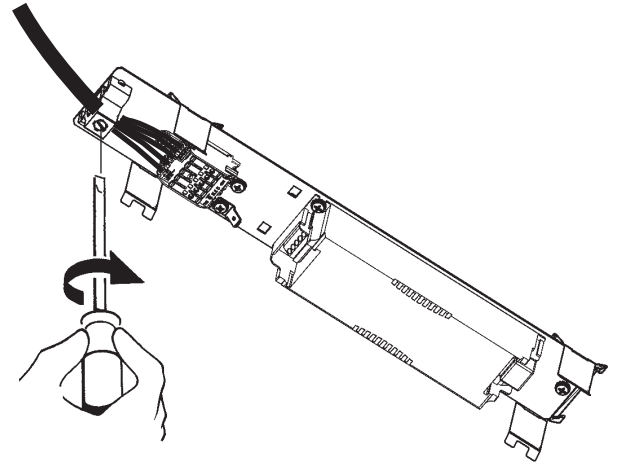
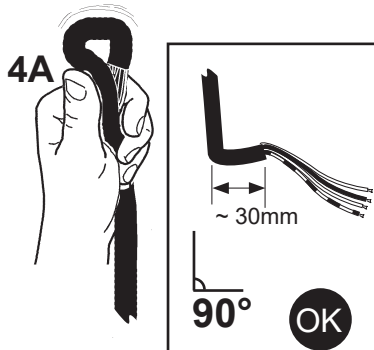
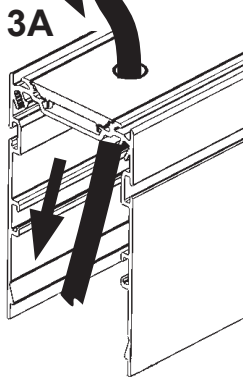
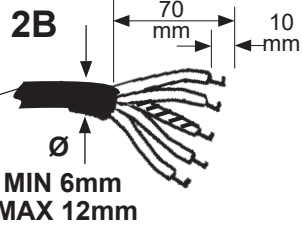

art. MWM2



art. PB32 - PB33

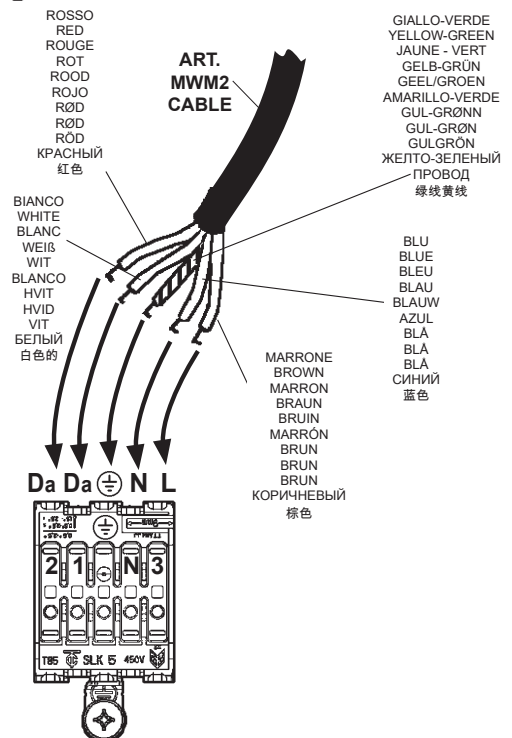
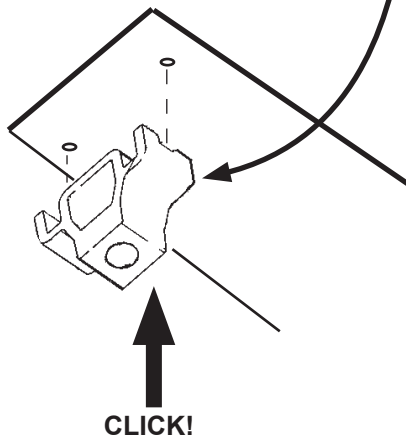
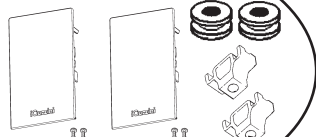

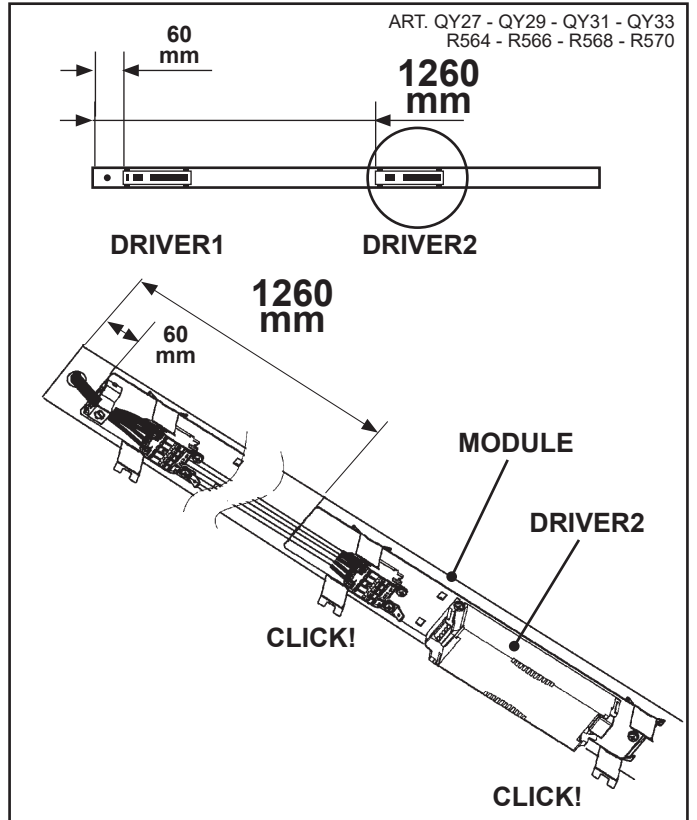
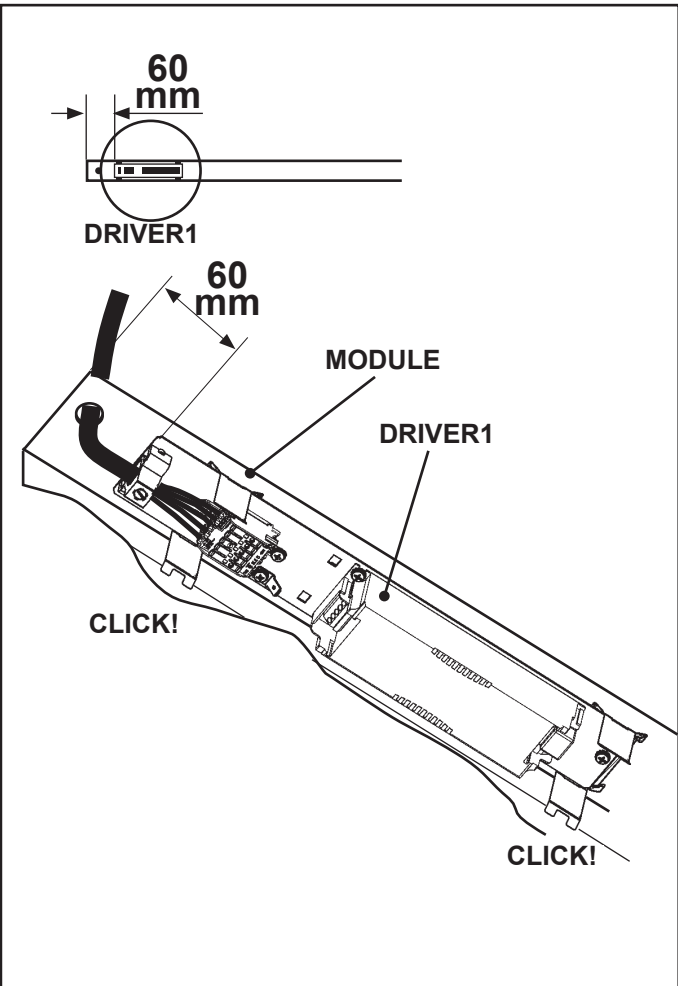
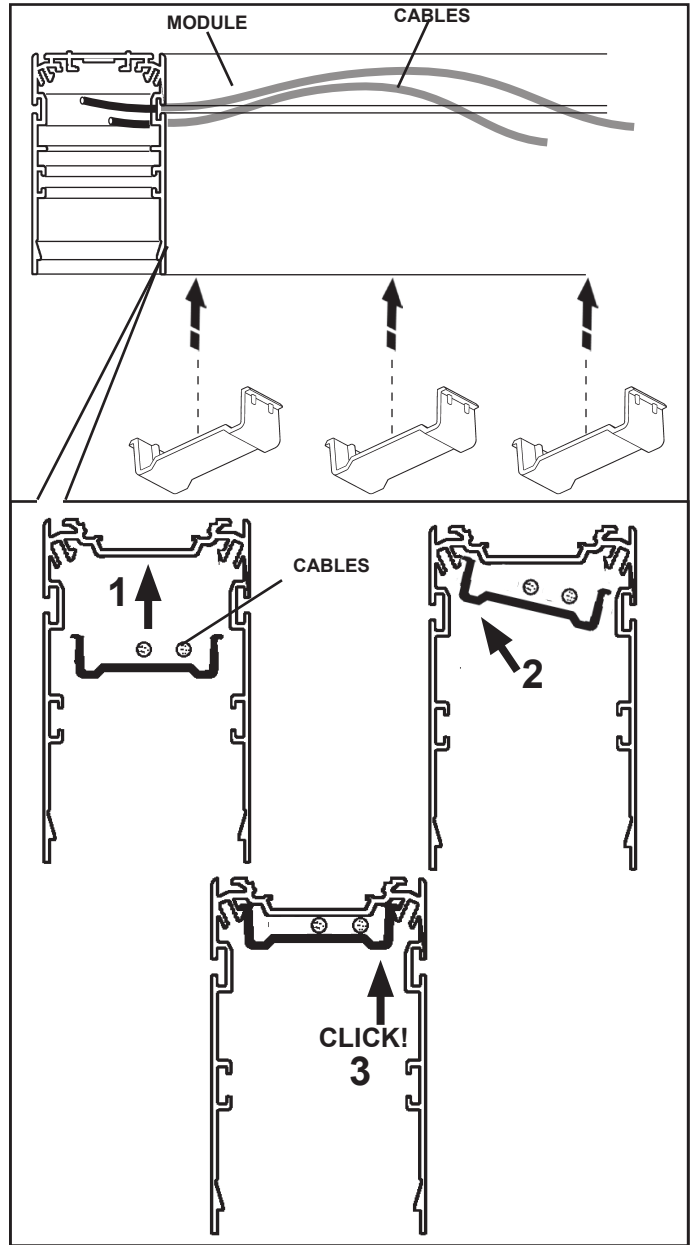
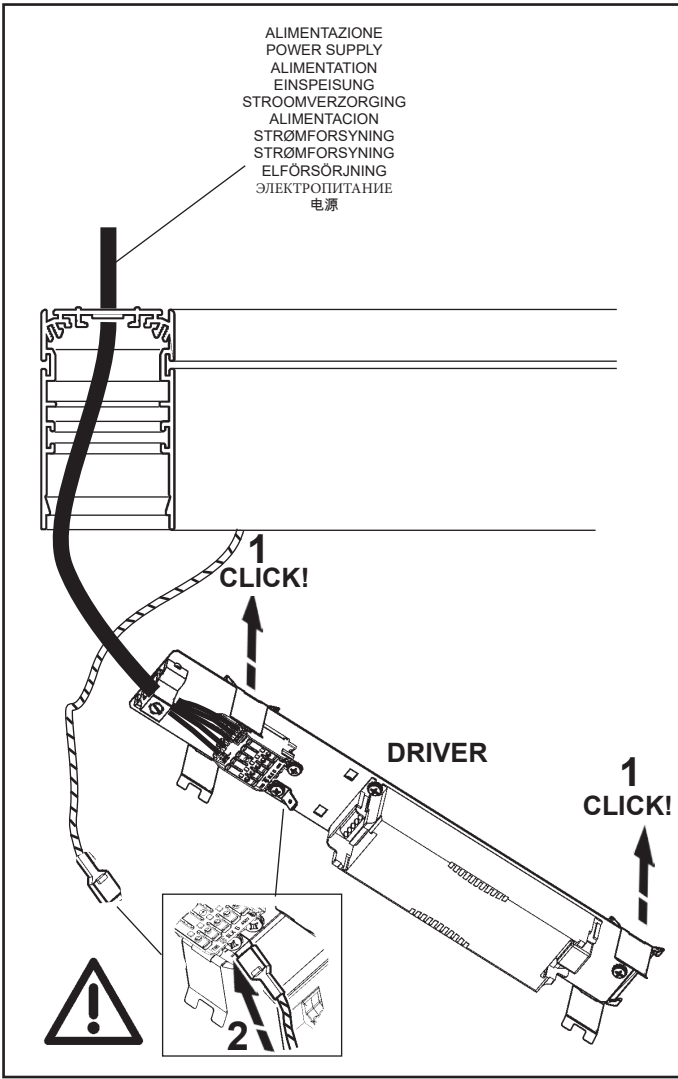

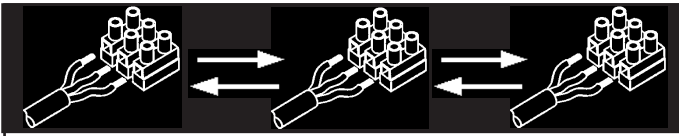

**art. PB34 - PB35**  
CABLES  
2,4m

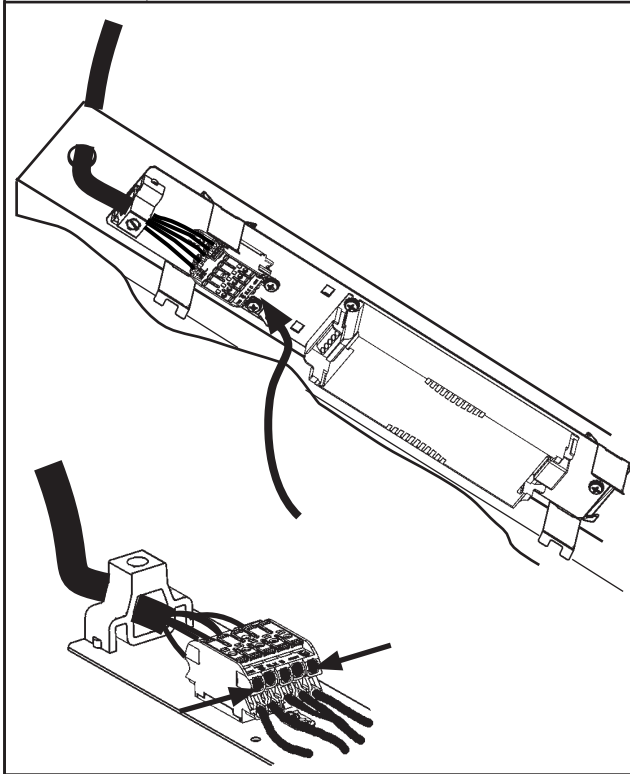

**art. QY27 - QY29 - QY31 - QY33**  
R564 - R566 - R568 - R570

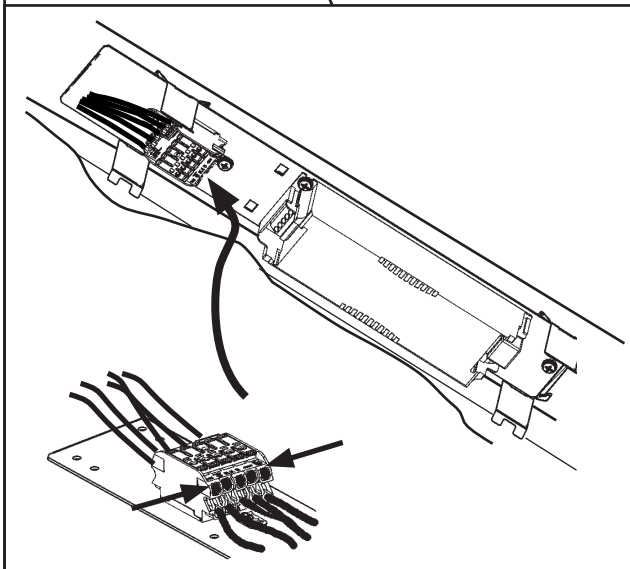

Da Da ⊕ N L

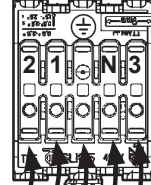

BIANCO  
WHITE  
BLANC  
WEISS  
WIT  
BLANCO  
HVID  
HVID  
ВИТ  
БЕЛЫЙ  
白色的

MARRONE  
BROWN  
MARRON  
BRAUN  
BRUN  
MARRÓN  
BRUN  
BRUN  
BRUN  
КОРИЧНЕВЫЙ  
棕色

**art. PB34 - PB35**  
CABLES  
2,4m

GIALLO-VERDE  
YELLOW-GREEN  
JAUNE - VERT  
GELB-GRÜN  
GELB-GRÜN  
AMARILLO-VERDE  
GUL-GRÖNN  
GUL-GRÖNN  
GULGRÖN  
ЖЕЛТО-ЗЕЛЕНЫЙ  
ПРОВОД  
绿线黄线

BLU  
BLUE  
BLEU  
BLAU  
BLAUW  
AZUL  
BLA  
BLA  
BLA  
СИНИЙ  
蓝色

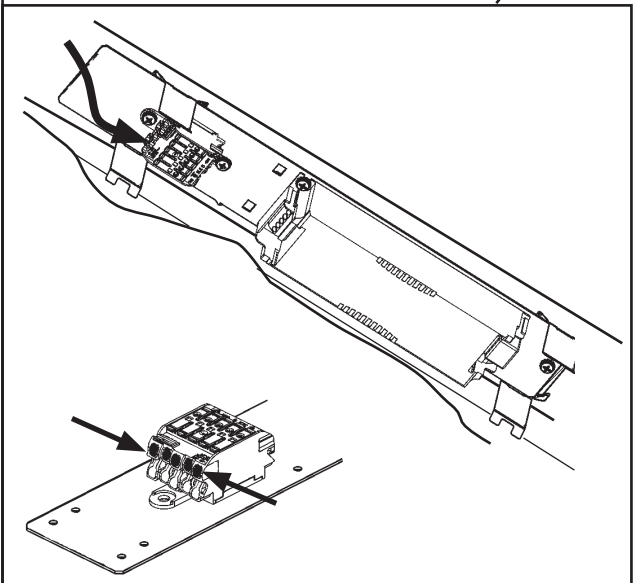
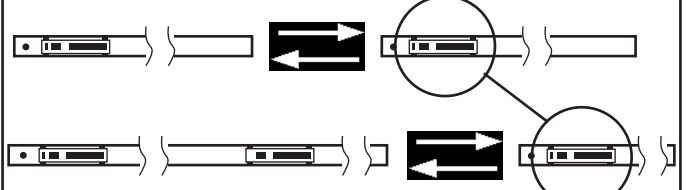

BIANCO  
WHITE  
BLANC  
WEISS  
WIT  
BLANCO  
HVID  
HVID  
ВИТ  
БЕЛЫЙ  
白色的

GIALLO-VERDE  
YELLOW-GREEN  
JAUNE - VERT  
GELB-GRÜN  
GELB-GRÜN  
AMARILLO-VERDE  
GUL-GRÖNN  
GUL-GRÖNN  
GULGRÖN  
ЖЕЛТО-ЗЕЛЕНЫЙ  
ПРОВОД  
绿线黄线

MARRONE  
BROWN  
MARRON  
BRAUN  
BRUN  
MARRÓN  
BRUN  
BRUN  
BRUN  
КОРИЧНЕВЫЙ  
棕色

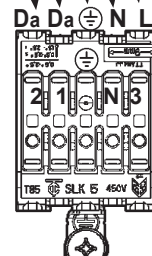

BLU  
BLUE  
BLEU  
BLAU  
BLAUW  
AZUL  
BLA  
BLA  
BLA  
СИНИЙ  
蓝色

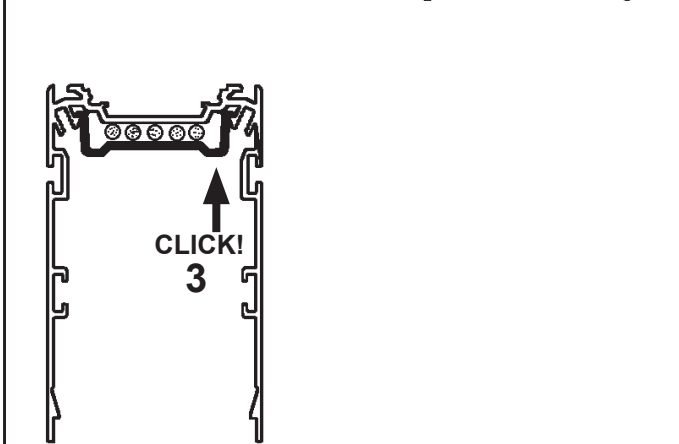
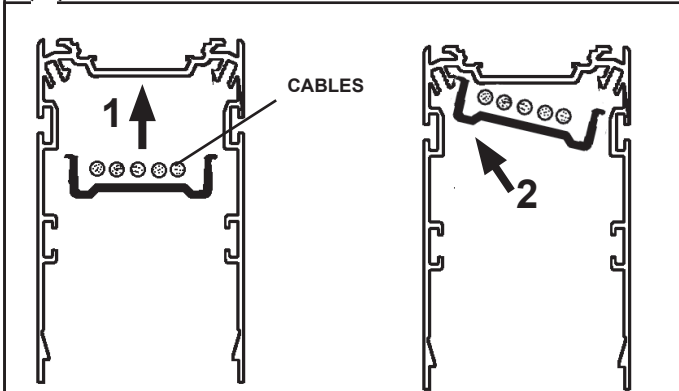
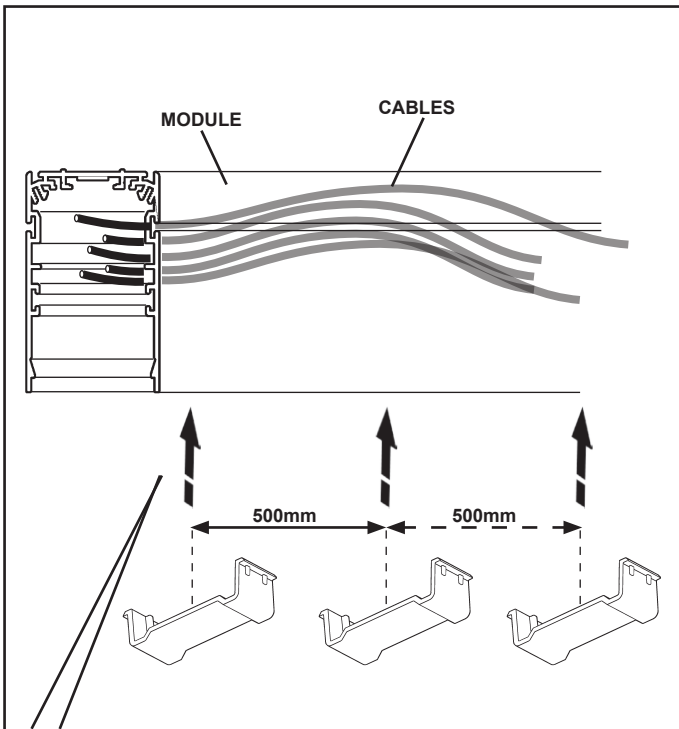

### UP/DOWN version

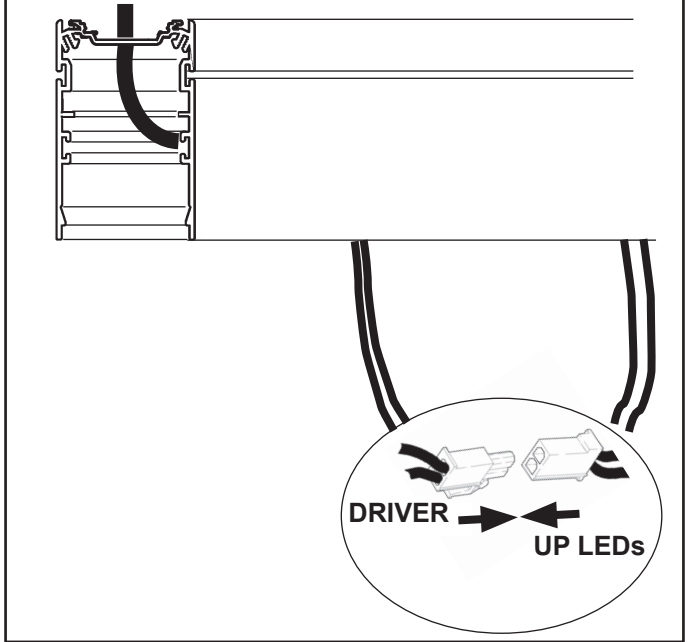



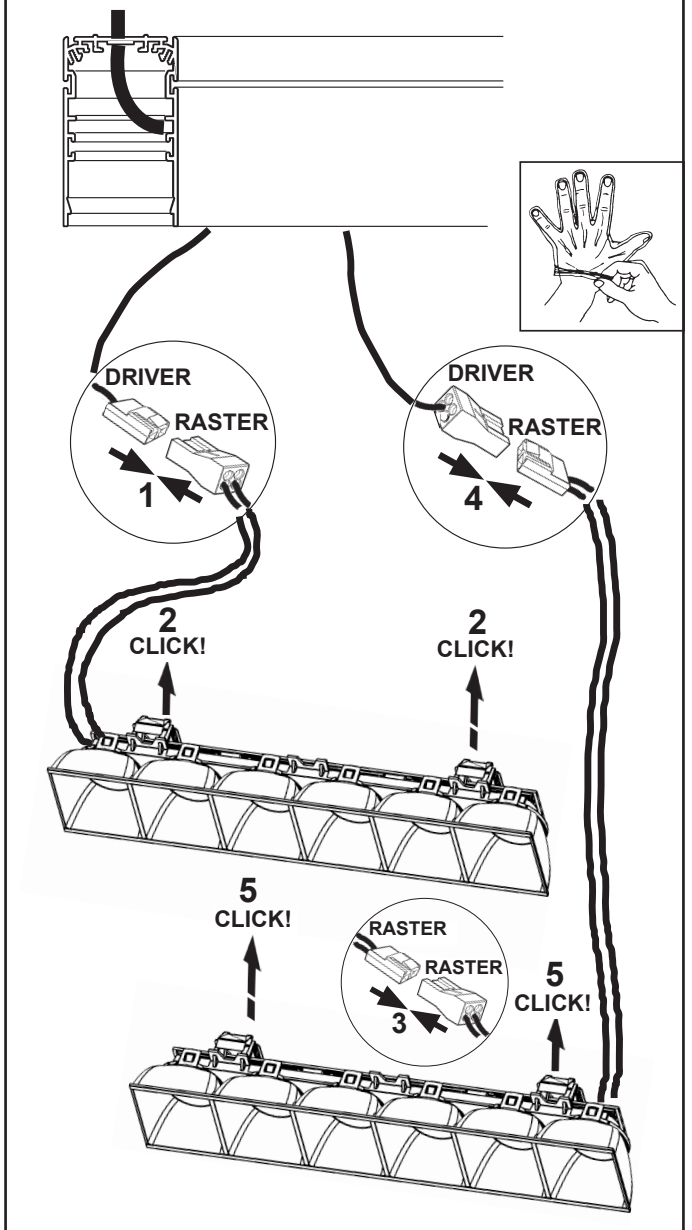



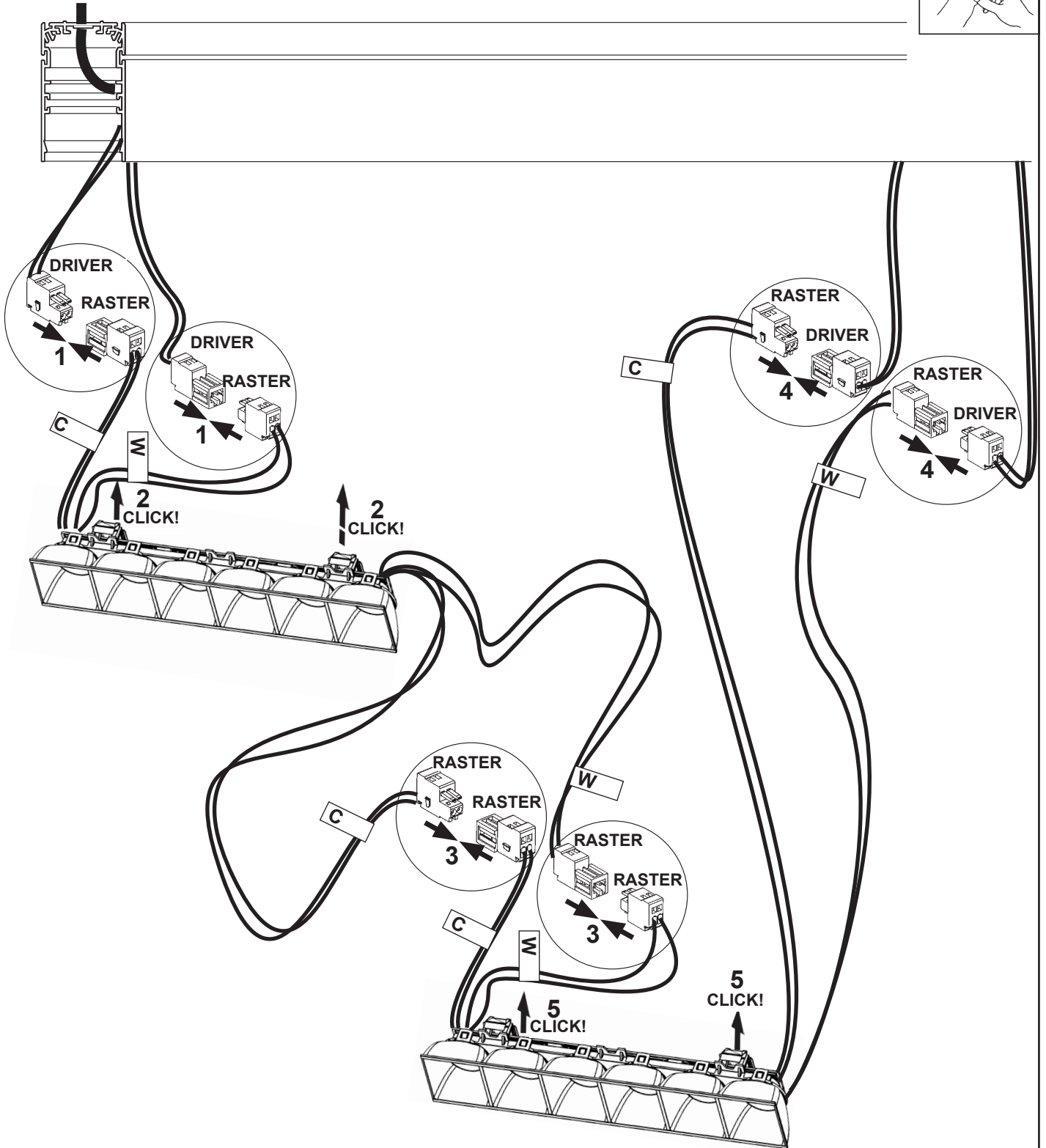
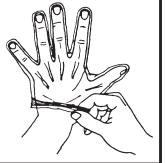

### DOWN version UP/DOWN version MONOCROMATIC

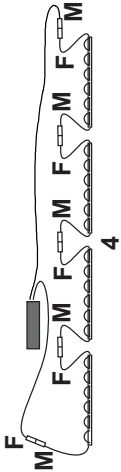

# UP/DOWN version TUNABLE WHITE

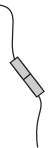
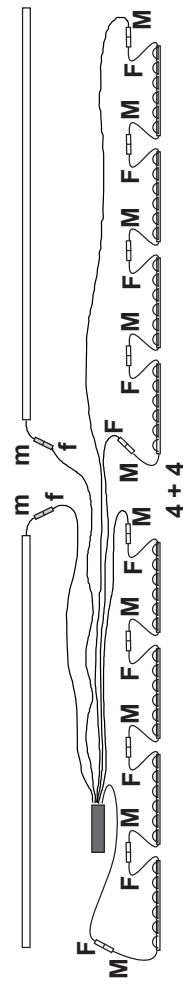
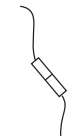
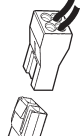
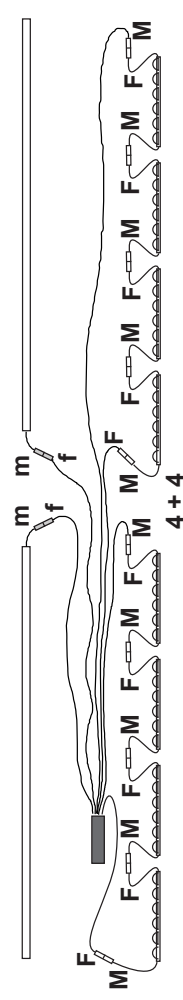
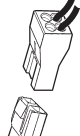
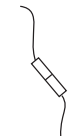

	 <b>RASTER ART.</b>	<b>RASTER CONFIGURATION</b>			
<b>L</b> (mm)					
<b>DOWN version</b>	<b>1192</b>  QX89 - QX90 - QX91 - QX92 - QX93 - QX94 - QX95 QX96 - QX97 - QX98 - QX99 - QY00 - QY01 - QY02 QY03 - QY04 - R526 - R527 - R528 - R529 - R530 R531 - R532 - R533 - R534 - R535 - R536 - R537 R538 - R539 - R540 - R541		<b>UP/DOWN version</b>	<b>2384</b>  QY18 - QY19 - QY20 - QY21 - QY22 - QY23 QY24 - QY25 - R555 - R556 - R557 - R558 R559 - R560 - R561 - R562	
	<b>1192</b>  MONOCROMATIC QY05 - QY06 - QY07 - QY08 - QY09 - QY10 - QY11 QY12 - QY14 - QY15 - QY16 - QY17 R542 - R543 - R544 - R545 - R546 - R547 - R548 R549 - R551 - R552 - R553 - R554  TUNABLE WHITE QY13 - R550	QY26 - QY28 - QY30 - QY32 R563 - R565 - R567 - R569			
	<b>2384</b>  QY27 - QY29 - QY31 - QY33 R564 - R566 - R568 - R570  QY34 - QY35 - QY36 - QY37 R571 - R572 - R573 - R574		 = female f	 male m	 = Female F  Male M
	 = Female F  Male M		 Female F  Male M		

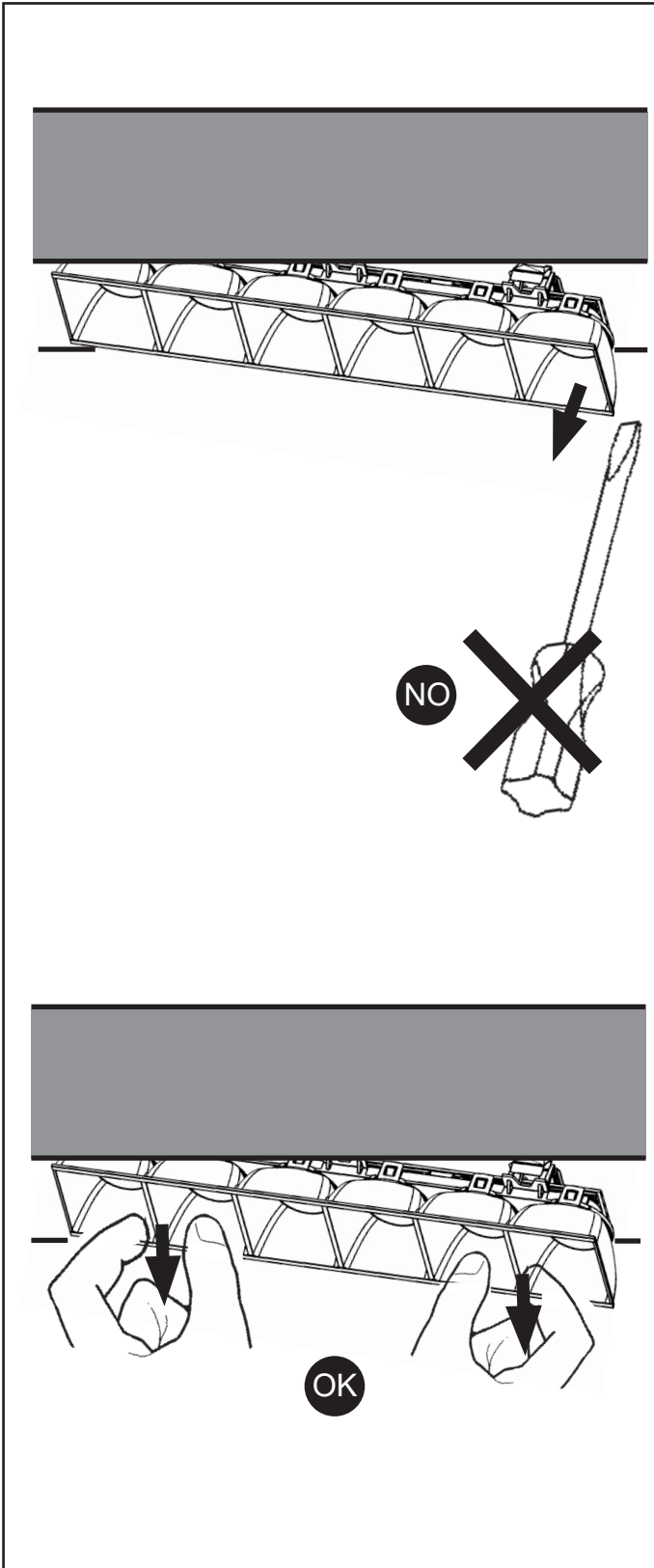
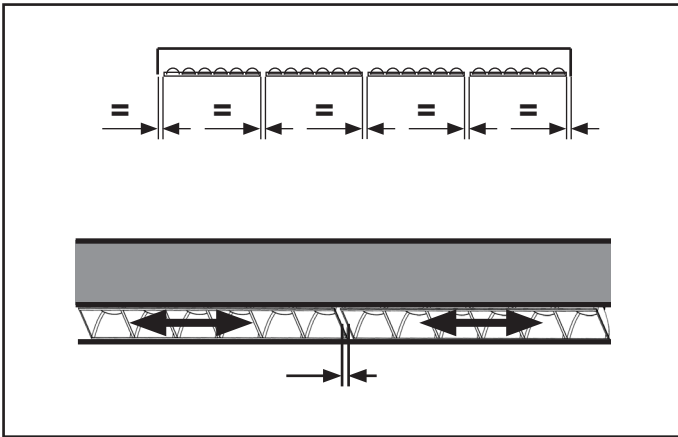

- IT** N.B.: Per l'eventuale pulizia non utilizzare acqua o solventi vari, usare esclusivamente panni morbidi asciutti.
- EN** N.B.: When cleaning, do not use water or any type of solvent. Use only soft dry cloths.
- FR** N.B.: En cas de nettoyage, n'utiliser ni eau ni solvants en général, n'utiliser que des chiffons doux et secs.
- DE** N.B.: Zur eventuellen Reinigung weder Wasser noch Lösungsmittel, sondern ausschließlich ein weiches, trockenes Tuch verwenden.
- NL** N.B.: Gebruik voor het sohoonmaken geen water of oplosmiddelen, maar uitsluitend zachte stofdoeken.
- ES** NOTA: Para la limpieza eventual no usar agua ni solventes de cualquier género, sino exclusivamente un pano suave y seco.
- DA** N.B.: Ved rengøring skal man undgå brug af vand eller forskellige opløsningsmidler. Brug udelukkende en tør, blød klud.
- NO** N.B.: For en eventuell rengjøring, ikke benytt vann eller ymse løsemidler, bruk kun tørre, myke kluter.
- SV** OBS! Använd inte vatten eller diverse lösningsmedel vid eventuell rengöring. Använd endast mjuka och torra trasor.
- RU** ПРИМЕЧАНИЕ: При необходимости произвести чистку не используйте воду или различные растворители, а исключительно сухие мягкие тряпки.
- ZH** 注意：不要用水或任何类型的溶剂进行清洗。只能使用干燥的软布。

- IT** N.B.: Per la sostituzione del LED contattare l'azienda iGuzzini.
- EN** N.B.: For information on LED replacement please contact iGuzzini.
- FR** N.B.: Pour procéder au remplacement de la LED, adressez-vous à la société iGuzzini.
- DE** Ñ.B.: Bezüglich des Austausches der LED kontaktieren Sie bitte die Firma iGuzzini.
- NL** N.B.: Voor het vervangen van de LED neemt u contact op met het bedrijf iGuzzini.
- ES** NOTA: Para sustituir el LED llame a la empresa iGuzzini.
- DA** N.B.: For udskiftning af lysdioden, skal man kontakte iGuzzini.
- NO** N.B.: For informasjon om skifte av LED, vennligst ta kontakt med iGuzzini.
- SV** OBS! För byte av lysdioden, kontakta företaget iGuzzini.
- RU** ПРИМЕЧАНИЕ: Для замены СИДов обращайтесь в компанию iGuzzini.
- ZH** 注意：如需LED更换的信息，请联系iGuzzini。

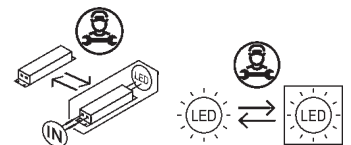

2.510.670.02 IS15971/03 <b>iGuzzini</b>		fattore di potenza power factor facteur de puissance Leistungsfaktor vermogensfactor factor de potencia effektfaktor effektfaktor фактор мощности 功率因数	corrente assorbita absorbed current courant absorbé Stromaufnahme stroomopname corriente absorbida absorberet strøm absorbert strøm tillförd ström поглощаемая мощность 电源电流
ART.	$\lambda$	A	
R526.D8 - R528.D8 - R530.D8 - R532.D8	>0,9	0,07	
R542.D8 - R544.D8 - R546.D8 - R548.D8	>0,9	0,09	
QX89 - QX91 - QX93 - QX95	>0,95	0,09	
R526.83 - R528.83 - R530.83 - R532.83 R550.D8	>0,9	0,1	
R555.D8 - R557.D8 - R559.D8 - R561.D8	>0,95	0,12	
QX90 - QX92 - QX94 - QX96 - R527 R529 - R531 - R533	>0,95	0,13	
QY05 - QY07 - QY09 - QY11	>0,95	0,14	
QY13	>0,9	0,15	
R542.83 - R544.83 - R546.83 - R548.83	>0,95	0,15	
QY18 - QY20 - QY22 - QY24	>0,95	0,16	
R550.83 - R563.D8 - R565.D8 - R567.D8 R569.D8	>0,95	0,17	
R555.83 - R557.83 - R559.83 - R561.83	>0,95	0,2	
QY06 - QY08 - QY10 - QY12 - R543 - R545 R547 - R549	>0,95	0,21	
QY14 - QY15 - QY16 - QY17 - R551 R552 - R553 - R554	>0,95	0,22	
QY19 - QY21 - QY23 - QY25 - R556 R558 - R560 - R562	>0,95	0,26	
QY26 - QY28 - QY30 - QY32	>0,95	0,27	
R563.83 - R565.83 - R567.83 - R569.83	>0,95	0,3	
QY27 - QY29 - QY31 - QY33 QY34 - QY35 - QY36 - QY37 R564 - R566 - R568 - R570 R571 - R572 - R573 - R574	>0,95	0,42	

2.510.670.02 IS15971/03 <b>iGuzzini</b>		fattore di potenza power factor facteur de puissance Leistungsfaktor vermogensfactor factor de potencia effektfaktor effektfaktor фактор мощности 功率因数	corrente assorbita absorbed current courant absorbé Stromaufnahme stroomopname corriente absorbida absorberet strøm absorbert strøm tillförd ström поглощаемая мощность 电源电流
ART.	$\lambda$	A	
R526.D8 - R528.D8 - R530.D8 - R532.D8	>0,9	0,07	
R542.D8 - R544.D8 - R546.D8 - R548.D8	>0,9	0,09	
QX89 - QX91 - QX93 - QX95	>0,95	0,09	
R526.83 - R528.83 - R530.83 - R532.83 R550.D8	>0,9	0,1	
R555.D8 - R557.D8 - R559.D8 - R561.D8	>0,95	0,12	
QX90 - QX92 - QX94 - QX96 - R527 R529 - R531 - R533	>0,95	0,13	
QY05 - QY07 - QY09 - QY11	>0,95	0,14	
QY13	>0,9	0,15	
R542.83 - R544.83 - R546.83 - R548.83	>0,95	0,15	
QY18 - QY20 - QY22 - QY24	>0,95	0,16	
R550.83 - R563.D8 - R565.D8 - R567.D8 R569.D8	>0,95	0,17	
R555.83 - R557.83 - R559.83 - R561.83	>0,95	0,2	
QY06 - QY08 - QY10 - QY12 - R543 - R545 R547 - R549	>0,95	0,21	
QY14 - QY15 - QY16 - QY17 - R551 R552 - R553 - R554	>0,95	0,22	
QY19 - QY21 - QY23 - QY25 - R556 R558 - R560 - R562	>0,95	0,26	
QY26 - QY28 - QY30 - QY32	>0,95	0,27	
R563.83 - R565.83 - R567.83 - R569.83	>0,95	0,3	
QY27 - QY29 - QY31 - QY33 QY34 - QY35 - QY36 - QY37 R564 - R566 - R568 - R570 R571 - R572 - R573 - R574	>0,95	0,42	

2.510.670.02 IS15971/03 <b>iGuzzini</b>		fattore di potenza power factor facteur de puissance Leistungsfaktor vermogensfactor factor de potencia effektfaktor effektfaktor фактор мощности 功率因数	corrente assorbita absorbed current courant absorbé Stromaufnahme stroomopname corriente absorbida absorberet strøm absorbert strøm tillförd ström поглощаемая мощность 电源电流
ART.	$\lambda$	A	
R526.D8 - R528.D8 - R530.D8 - R532.D8	>0,9	0,07	
R542.D8 - R544.D8 - R546.D8 - R548.D8	>0,9	0,09	
QX89 - QX91 - QX93 - QX95	>0,95	0,09	
R526.83 - R528.83 - R530.83 - R532.83 R550.D8	>0,9	0,1	
R555.D8 - R557.D8 - R559.D8 - R561.D8	>0,95	0,12	
QX90 - QX92 - QX94 - QX96 - R527 R529 - R531 - R533	>0,95	0,13	
QY05 - QY07 - QY09 - QY11	>0,95	0,14	
QY13	>0,9	0,15	
R542.83 - R544.83 - R546.83 - R548.83	>0,95	0,15	
QY18 - QY20 - QY22 - QY24	>0,95	0,16	
R550.83 - R563.D8 - R565.D8 - R567.D8 R569.D8	>0,95	0,17	
R555.83 - R557.83 - R559.83 - R561.83	>0,95	0,2	
QY06 - QY08 - QY10 - QY12 - R543 - R545 R547 - R549	>0,95	0,21	
QY14 - QY15 - QY16 - QY17 - R551 R552 - R553 - R554	>0,95	0,22	
QY19 - QY21 - QY23 - QY25 - R556 R558 - R560 - R562	>0,95	0,26	
QY26 - QY28 - QY30 - QY32	>0,95	0,27	
R563.83 - R565.83 - R567.83 - R569.83	>0,95	0,3	
QY27 - QY29 - QY31 - QY33 QY34 - QY35 - QY36 - QY37 R564 - R566 - R568 - R570 R571 - R572 - R573 - R574	>0,95	0,42	

2.510.670.02 IS15971/03 <b>iGuzzini</b>		fattore di potenza power factor facteur de puissance Leistungsfaktor vermogensfactor factor de potencia effektfaktor effektfaktor фактор мощности 功率因数	corrente assorbita absorbed current courant absorbé Stromaufnahme stroomopname corriente absorbida absorberet strøm absorbert strøm tillförd ström поглощаемая мощность 电源电流
ART.	$\lambda$	A	
R526.D8 - R528.D8 - R530.D8 - R532.D8	>0,9	0,07	
R542.D8 - R544.D8 - R546.D8 - R548.D8	>0,9	0,09	
QX89 - QX91 - QX93 - QX95	>0,95	0,09	
R526.83 - R528.83 - R530.83 - R532.83 R550.D8	>0,9	0,1	
R555.D8 - R557.D8 - R559.D8 - R561.D8	>0,95	0,12	
QX90 - QX92 - QX94 - QX96 - R527 R529 - R531 - R533	>0,95	0,13	
QY05 - QY07 - QY09 - QY11	>0,95	0,14	
QY13	>0,9	0,15	
R542.83 - R544.83 - R546.83 - R548.83	>0,95	0,15	
QY18 - QY20 - QY22 - QY24	>0,95	0,16	
R550.83 - R563.D8 - R565.D8 - R567.D8 R569.D8	>0,95	0,17	
R555.83 - R557.83 - R559.83 - R561.83	>0,95	0,2	
QY06 - QY08 - QY10 - QY12 - R543 - R545 R547 - R549	>0,95	0,21	
QY14 - QY15 - QY16 - QY17 - R551 R552 - R553 - R554	>0,95	0,22	
QY19 - QY21 - QY23 - QY25 - R556 R558 - R560 - R562	>0,95	0,26	
QY26 - QY28 - QY30 - QY32	>0,95	0,27	
R563.83 - R565.83 - R567.83 - R569.83	>0,95	0,3	
QY27 - QY29 - QY31 - QY33 QY34 - QY35 - QY36 - QY37 R564 - R566 - R568 - R570 R571 - R572 - R573 - R574	>0,95	0,42	





- I Istruzioni per le operazioni di servizio per l'apparecchio di illuminazione**  
**GB Instructions on luminaire service operations**  
**F Instructions pour les opérations de service du luminaire**  
**D Wartungsanleitung für die Leuchte**  
**NL Instructies voor de onderhoudsoperaties op de verlichtingsarmatuur**  
**E Instrucciones para las operaciones de servicio del aparato de alumbrado**  
**DK Anvisninger i serviceindgreb på belysningsarmatur**  
**N Anvisninger for betjening av lysapparatet**  
**S Instruktioner för användning av belysningsanordningen**  
**RUS Инструкции по эксплуатации осветительного прибора**  
**CN 照明装置检修操作说明**

**Sostituire la lampada parzialmente esausta**  
 Replace the partly exhausted lamp  
 Remplacer la lampe partiellement épuisée  
 Die teilweise erschöpfte Lampe austauschen  
 Vervang de gedeeltelijk lege lamp  
 Sustituir la lámpara parzialmente agotada  
 Udskift den delvist udtjente pære  
 Skifte ut den delvis utbrænte lyspæren  
 Byt ut den delvis förbrukade lampan  
 Замена частично отработанной лампочки  
 更换部分老化的灯泡



**Spegnimento**  
 Switch it off  
 Extinction  
 Ausschaltung  
 Uitschakeling  
 Apagado  
 Slukning  
 Slukking  
 Släckning  
 Выключение  
 关灯

**Interrompere l'alimentazione dell'apparecchio**  
 Cut the power supply to the luminaire  
 Couper l'alimentation du luminaire  
 Stromversorgung der Leuchte unterbrechen  
 Onderbreek de voeding van het apparaat  
 Interrumpir la alimentación del aparato  
 Afbryd armaturets strømforsyning  
 Avbryt strømtilførselen til apparatet  
 Koppla från anordningens strömförsörjning  
 Отключить электропитание прибора  
 中断装置供电



**Aprire l'apparecchio**  
 Open the fixture  
 Ouvrir le luminaire  
 Das Gerät öffnen  
 Open het apparaat  
 Abrir el aparato  
 Åbn armaturet  
 Åpne apparatet  
 Öppna anordningen  
 Раскрыть прибор  
 打开装置



**Rimuovere la lampada esausta**  
 Remove the exhausted lamp  
 Retirer la lampe épuisée  
 Die alte Lampe entnehmen  
 Verwijder de lege lamp  
 Quitar la lámpara agotada  
 Tag den udtjente pære ud  
 Fjerne den utbrænte lyspæren  
 Ta bort den förbrukade lampan  
 Вынуть старую лампочку  
 取出老化的灯泡

**Portarla in un centro di riciclaggio**  
 Carry it to a recycling centre  
 La porter dans une déchetterie pour son recyclage  
 Ordnungsgemäß entsorgen  
 Breng de lamp naar een recyclingcentrum  
 Llevarla a un centro de reciclaje  
 Aflever den på en genbrugsstation  
 Lever den til en miljøstasjon  
 Lämna in den till en återvinningsanläggning  
 Сдать ее в пункт приема утильсырья  
 将其送往回收中心



**Inserire la nuova lampada**  
 Introduce the new lamp  
 Installer la lampe neuve  
 Die neue Lampe einsetzen  
 Doe de nieuwe lamp op zijn plek  
 Montar la nueva lámpara  
 Sæt den nye pære i  
 Sette i den nye pæren  
 Sätt i den nya lampan  
 Вставить новую лампочку  
 装入新灯泡

**Inserire la nuova lampada nel portalampana**  
 Fit the new lamp into the socket  
 Installer la nouvelle lampe dans le support de lampe  
 Die neue Lampe in den Sockel einsetzen  
 Doe de nieuwe lamp in de lamphouder  
 Montar la nueva lámpara en el portalampana  
 Sæt den nye pære i fatningen  
 Sette den nye pæren inn i lampeholderen  
 Sätt i den nya lampan i lamphållaren  
 Вставить новую лампочку в патрон  
 将新灯泡插入灯泡架中

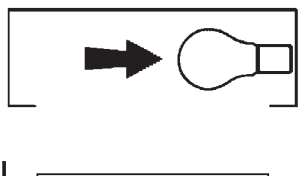

**Riposizionare ottica**  
 Re-place the optic  
 Remettre l'optique à sa place  
 Die Optik wieder einsetzen  
 Doe de optiek weer op zijn plaats  
 Volver a montar la óptica  
 Sæt den optiske enhed på plads  
 Innstille linsen  
 Flytta om optiken  
 Отрегулировать линзы  
 重新定位光头

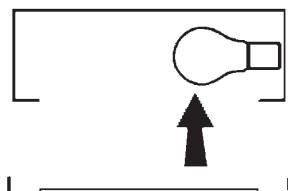

**Effettuare prova di funzionamento**  
 Perform operative test  
 Procéder à un essai de fonctionnement  
 Eine Funktionsprüfung durchführen  
 Controleer de correcte werking  
 Hacer una prueba de funcionamiento  
 Afprøv funktionen  
 Prøve om den fungerer  
 Utför funktionstest  
 Выполнить проверку исправности работы  
 执行功能测试



- I Istruzioni per la pulizia dell'apparecchio di illuminazione  
 GB Instructions on luminaire cleaning operations  
 F Instructions pour le nettoyage du luminaire  
 D Anweisungen zur Reinigung der Leuchte  
 NL Instructies voor de reiniging van de verlichtingsarmatuur  
 E Instrucciones para limpiar el aparato de alumbrado  
 DK Anvisninger i rengøring af belysningsarmaturet  
 N Anvisninger for rengjøring av lysapparatet  
 S Instruktioner för rengöring av belysningsanordningen  
 RUS Инструкции по чистке осветительного прибора  
 CN 照明装置清洁说明

Pulire l'apparecchio  
 Clean the fixture  
 Nettoyer le luminaire  
 Das Gerät reinigen  
 Reinig het apparaat  
 Limpiar el aparato  
 Rengør armaturet  
 Rengjøre apparatet  
 Rengör anordningen  
 Чистка прибора  
 清洁装置



Spegnimento  
 Switch it off  
 Extinction  
 Ausschaltung  
 Uitschakeling  
 Apagado  
 Slukning  
 Slukking  
 Släckning  
 Выключение  
 关灯

Interrompere l'alimentazione dell'apparecchio  
 Cut the power supply to the luminaire  
 Couper l'alimentation du luminaire  
 Stromversorgung der Leuchte unterbrechen  
 Onderbreek de voeding van het apparaat  
 Interrumpir la alimentación del aparato  
 Afbryd armaturets strømforsyning  
 Avbryt strømtilførselen til apparatet  
 Koppla från anordningens strömförsörjning  
 Отключить электропитание прибора  
 中断装置供电



Spolverare l'ottica esterna  
 Remove dust from the external optic  
 Dépoussiérer l'optique extérieure  
 Die externe Optik abstauben  
 Stof de externe optiek af  
 Quitar el polvo de la óptica exterior  
 Tør støvet af den udvendige optiske enhed  
 Fjerne støv fra den eksterne lysenheden  
 Damma av den yttre optiken  
 Вытереть пыль с внешней стороны линз  
 为外侧镜头掸尘



Lavare l'ottica esterna  
 Wash the external optic  
 Laver l'optique extérieure  
 Die externe Optik waschen  
 Was de externe optiek  
 Lavar la óptica exterior  
 Vask den udvendige optiske enhed  
 Vaske den eksterne lysenheden  
 Rengör den yttre optiken  
 Вымыть линзы с внешней стороны  
 清洁外镜头



Rimuovere l'ottica  
 Remove the optic  
 Retirer l'optique  
 Die Optik abnehmen  
 Verwijder de optiek  
 Quitar la óptica  
 Tag den optiske enhed af  
 Fjerne lysenheden  
 Ta bort optiken  
 Снять линзы  
 取下镜头



Pulire la parte interna dell'apparecchio di illuminazione  
 Clean the inside of the fixture  
 Nettoyer l'intérieur du luminaire  
 Die Innenseite der Leuchte reinigen  
 Reinig de binnenzijde van de verlichtingsarmatuur  
 Limpiar el interior del aparato de alumbrado  
 Rengør belysningsarmaturets indvendige dele  
 Rengjøre lysapparatet innvendig  
 Rengör belysningsanordningen invändigt  
 Протереть осветительный прибор изнутри  
 清洁照明装置内部



Riposizionare ottica  
 Re-place the optic  
 Remettre l'optique à sa place  
 Die Optik wieder einsetzen  
 Doe de optiek weer op zijn plaats  
 Volver a montar la óptica  
 Sæt den optiske enhed på plads  
 Innstille linsen  
 Flytta om optiken  
 Отрегулировать линзы  
 重新定位镜头

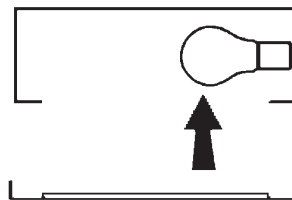

Effettuare prova di funzionamento  
 Perform operative test  
 Procéder à un essai de fonctionnement  
 Eine Funktionsprüfung durchführen  
 Controleer de correcte werking  
 Hacer una prueba de funcionamiento  
 Afprøv funktionen  
 Prøve om den fungerer  
 Utför funktionstest  
 Выполнить проверку исправности работы  
 执行功能测试

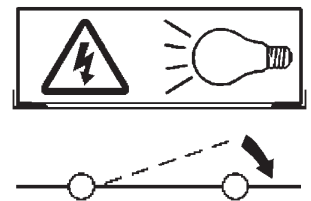

- I Istruzioni per il fine vita e lo smaltimento dei componenti**  
**GB Instructions on end-of-life and component disposal**  
**F Instructions pour la gestion des composants en fin de vie et leur mise au rebut**  
**D Anweisungen zur Entsorgung der Leuchtenkomponenten**  
**NL Instructies voor het verwijderen van de armatuur en het recyclen van de onderdelen**  
**E Instrucciones para el final de vida y la eliminación los componentes**  
**DK Anvisninger i udtjent armatur og bortskaffelse af komponenter**  
**N Anvisninger for endt levetid og avfallsbehandling av delene**  
**S Instruktionser vid bortskaffning och kassering av komponenter**  
**RUS Инструкции по утилизации прибора и его комплектующих по окончании его срока службы**  
**CN 寿命期结束与零件废弃处置说明**

Spegnimento  
Switch it off  
Extinction  
Ausschaltung  
Uitschakeling  
Apagado  
Slukning  
Slukking  
Släckning  
Выключение  
关灯

Interrompere l'alimentazione dell'apparecchio  
Cut the power supply to the luminaire  
Couper l'alimentation du luminaire  
Stromversorgung der Leuchte unterbrechen  
Onderbreek de voeding van het apparaat  
Interrompirla alimentación del aparato  
Afbryd armaturets strømforsyning  
Avbryt strømtilførselen til apparatet  
Koppla från anordningens strömförsörjning  
Отключить электропитание прибора  
中断装置供电



Rimuovere la/e lampada/e per la dismissione  
Remove the lamp(s) for decommissioning  
Retirer la(les) lampe(s) pour sa(leur) mise au rebut  
Die Lampe/n ordnungsgemäß entsorgen  
Verwijder de lamp(en) voor het recyclen  
Quitar la(s) lámpara(s) para el desecho  
Tag pæren/pærerne ud til bortskaffelse  
Fjerne lampen/-e som skal kastes  
Ta bort lampan/-orna för bortskaffningen  
Вынуть лампочку/и для утилизации прибора  
取出需要丢弃的灯泡



Rimuovere la batteria per la dismissione  
Remove the battery for decommissioning  
Retirer la batterie pour sa mise au rebut  
Die Batterie ordnungsgemäß entsorgen  
Verwijder de batterij voor het recyclen  
Quitar la batería para el desecho  
Tag batteriet ud til bortskaffelse  
Fjerne batteriet som skal kastes  
Ta bort batteriet för bortskaffningen  
Вынуть батарейку для утилизации прибора  
取出需要丢弃的电池

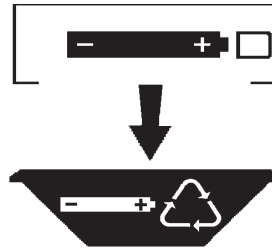

Rimuovere l'apparecchio per la dismissione  
Remove the fixture for decommissioning  
Enlever le luminaire pour sa mise au rebut  
Das Gerät ordnungsgemäß entsorgen  
Verwijder het apparaat voor het recyclen  
Quitar el aparato para el desecho  
Tag armaturet ud til bortskaffelse  
Fjerne apparatet som skal kastes  
Ta bort anordningen för bortskaffningen  
Снять прибор для утилизации  
取出需要丢弃的装置



Inviare i materiali ad un centro di raccolta  
RAEE  
Send the materials to a WEEE collection  
centre  
Envoyer les matériaux dans une déchetterie  
DEEE  
Die Materialien in einem WEEE-Zentrum  
entsorgen  
Zend de materialen naar een recyclingscentrum  
voor de AEEA  
Enviar los materiales a un centro de recogida  
RAEE  
Afløver materialerne på et indsamlingscenter  
for elektronisk udstyr  
Sende materialene til en miljøstasjon for  
resirkulering av EE-avfall  
Skicka materialet till en RAEE uppsamlingscentral  
Сдать материалы в пункт приема утильсырья  
将材料送往电气和电子垃圾回收中心

