

SPIKE FOR GROUND/GARDEN APPLICATIONS WITH DRIVER

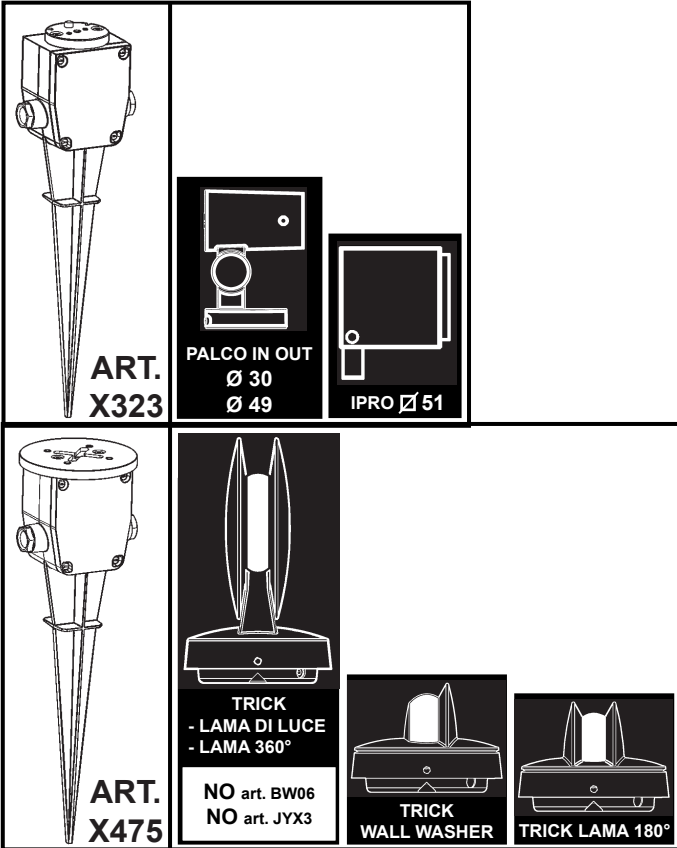

- IT Attenzione:**
La sicurezza dell'apparecchio e' garantita solo con l'uso appropriato delle seguenti istruzioni; pertanto e' necessario conservarle.
- EN Warning:**
The safety of this fixture is guaranteed only if you comply with these instructions; remember to conserve in a safe place.
- FR Attention:**
La sécurité de l'appareil n'est garantie qu'en cas d'utilisation correcte des instructions suivantes; il faut par conséquent les conserver.
- DE Achtung:**
Die sicherheit des gerätes wird nur durch sachgemässe befolgung nachstehender anweisungen gewährleitet; ihre aufbewahrung ist deshalb sehr wichtig.
- NL Opgelet:**
De veiligheid van di atoestel is slechts dan gegarandeerd als indien de volgende instructies strikt worden toegepast: daarom moet men ze ook bewaren.
- ES Atencion:**
La seguridad del aparato se garantiza solo cumpliendo cuidadosamente las siguientes instrucciones; por ello, es necesario conservarlas.
- DA Bemærk:**
Sikkerheden ved brug af armaturet kan kun garanteres, hvis disse anvisninger følges; sørg derfor for at gemme dem.
- NO Advarsel:**
Sikkerheten til dette apparatet garanteres kun hvis du overholder disse instruksjonene; husk å oppbevare dem på et trygt sted.
- SV Observera:**
Utrustningens säkerhet kan endast garanteras om dessa anvisningar respekteras i detalj. Spara därför dessa anvisningar för framtida konsultation.
- RU Внимание:**
Мы гарантируем безопасную эксплуатацию изделия только при соблюдении следующих инструкций; с этой целью необходимо сохранить данную брошюру.
- ZH 警告:**
为确保该装置安全, 请遵守操作指示; 并于安全场所放置。
- AR تحذير:**
لا يمكن ضمان سلامة هذا الجهاز إلا إذا التزمت بهذه التعليمات. يجب حفظها في مكان آمن.

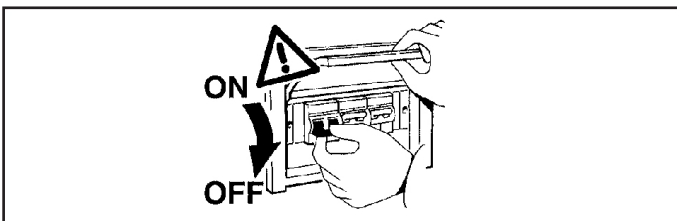

art. BU10 - BU16 - BU24 - BU25 - BU27

- IT** Flusso luminoso ridotto con l'utilizzo del picchetto X475. Max 350mA.
- EN** Light flow is reduced if the X475 stake is used. Max 350mA.
- FR** Flux lumineux réduit avec utilisation du piquet X475. Max 350mA.
- DE** Reduzierter Lichtstrom mit Verwendung von Erdspeiß X475. Max. 350 mA.
- NL** Beperkte lichtstroom bij het gebruik van grondpen X475. Max 350mA.
- ES** Flujo luminoso reducido con el uso de la piqueta X475. 350mA máx.
- DA** Reduceret lysflow ved brug af jordspyd X475. Max 350mA.
- NO** Redusert lysstrøm med bruk av festet X475. Maks 350mA.
- SV** Reducerat ljusflöde vid användning av jordspett X475. Max 350mA.
- RU** Уменьшенный световой поток при использовании кольшковой модификации. Макс. ток 350 mA.
- ZH** 此产品的正常运行只有在使用IGUZZINI的轨道及配件的情况下才可以保证
- AR** ينخفض التدفق الضوئي باستخدام وتد العرس X475 بحد أقصى 350 مللي أمبير.

- IT N.B.:** Durante l'installazione del sistema rispettare scrupolosamente le norme impiantistiche vigenti.
- EN N.B.:** When installing the system, strictly comply with all regulations on installation in force.
- FR N.B.:** Lors de l'installation du système veuillez respecter rigoureusement les normes en vigueur en la matière.
- DE N.B.:** Beachten sie bei der installation des systems gewissenhaft die gültigen bestimmungen bezüglich der anlagentechnik.
- NL N.B.:** Bij het installeren van het systeem moet u de gelden de installatienormen strikt naleven.
- ES N.B.:** Durante la instalación del sistema respetar e scrupulosamente las normas de instalación vigentes.
- DA N.B.:** Under installation af systemet skal man nøje overholde de gældende regler for disse anlæg.
- NO N.B.:** Ved installasjon av systemet skal alle forskrifter om installasjon som gjelder følges strengt.
- SV OBS.:** Under installationen av systemet ska installationsföreskrifterna respekteras i detalj.
- RU примечание:** в процессе монтажа системы строго соблюдайте национальные действующие нормативы по электропроводке.
- ZH 注意:** 在安装系统时请遵守设备的安装规定。
- AR ملاحظة:** أثناء تركيب النظام يجب التقيد بحرص بالنظم الساندة المتعلقة بالشبكة الكهربائية.

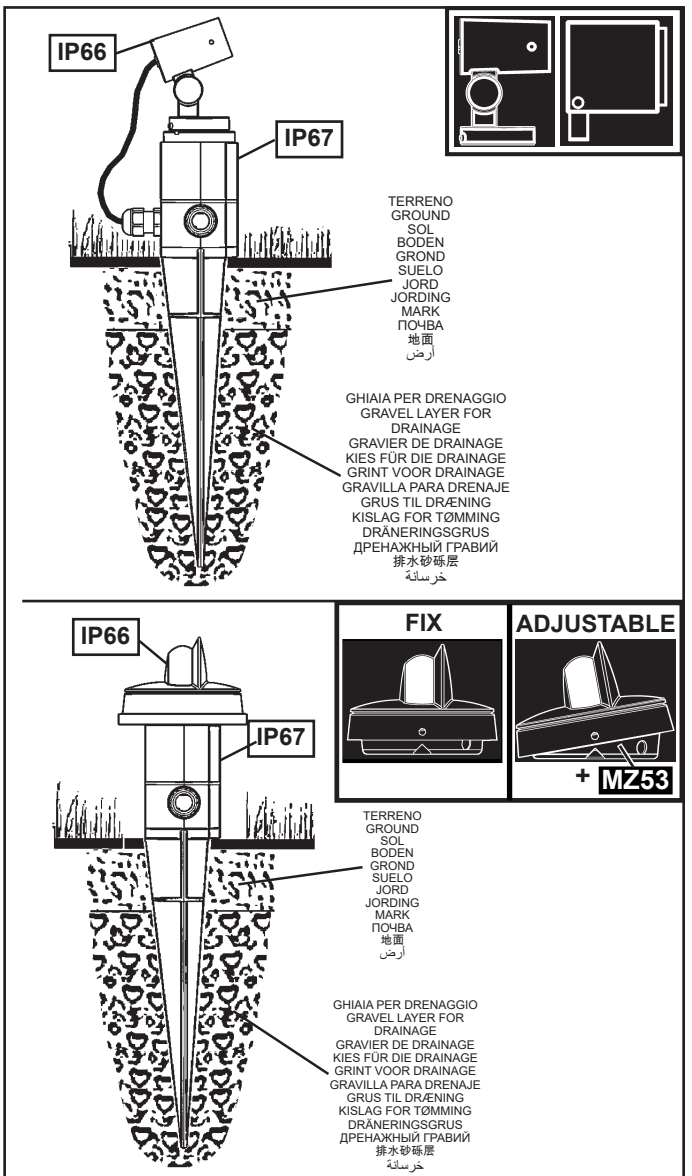

IT N.B.: Evitare il contatto diretto del prodotto con il terreno.
 EN NB: Avoid letting the product come into direct contact with the ground.
 FR N.B. : Éviter le contact direct du produit avec le sol.
 DE HINWEIS: Den direkten Kontakt des Geräts mit dem Erdboden vermeiden.
 NL N.B.: Vermijd direct contact van het product met de grond.
 ES Nota: Evitar el contacto directo del producto con el terreno.
 DA N.B.: Undgå direkte kontakt af produktet med jorden.
 NO NB! Unngå at produktet kommer i direkte kontakt med bakken.
 SV OBS! Undvik att produkten kommer i direkt kontakt med marken.
 RU Примечание: Избегайте прямого контакта изделия с землей.
 ZH 注意：避免產品與地面直接接觸。

AR ملاحظة: تجنب أن يلامس المنتج الأرض مباشرة.

IT Non installare il prodotto in luoghi soggetti al ristagno dell'acqua.
 EN Do not install the fixture in areas where water tends to collect.
 FR Ne pas installer le produit dans des endroits à risque de stagnation d'eau.
 DE Die Beleuchtungskörper nicht in Bereichen, die der Wasseranstauung unterworfen sind, installieren.
 NL Installeer het product niet op een vochtige plaats.
 ES No usar el producto para instalaciones en lugares donde hay agua estancada.
 DA Installer aldrig produktet et sted, hvor der kan ophobe sig vand.
 NO Ikke installere produktet på steder der det samler seg vann.
 SV Installera inte produktet på platser där vatten kan ansamlas.
 RU Не устанавливайте изделие в местах, в которых может застаиваться вода.
 ZH 请勿将灯具安装在容易积水的地方。

AR لا تتركب الجهاز في الأماكن التي يتجمع فيها الماء.

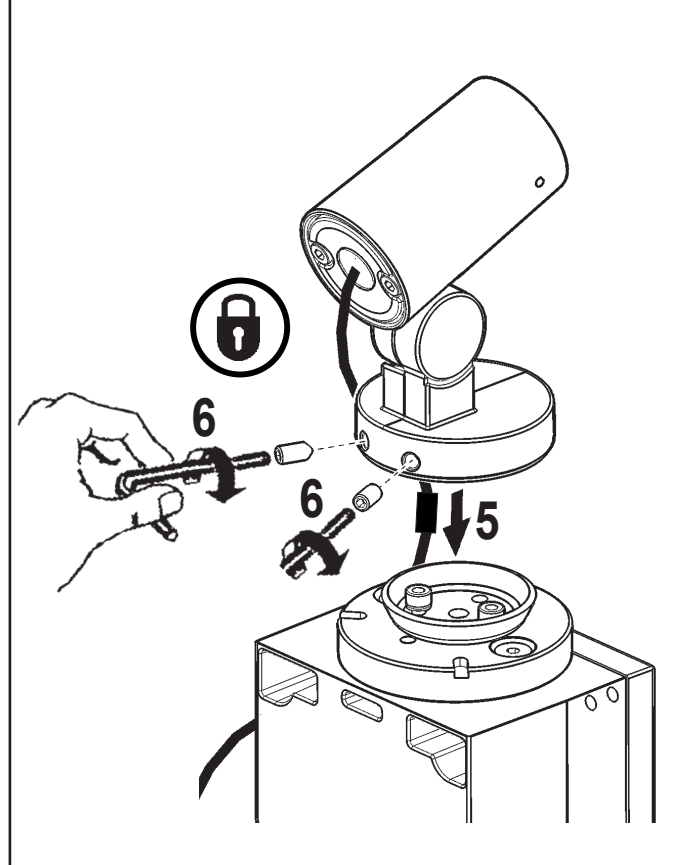
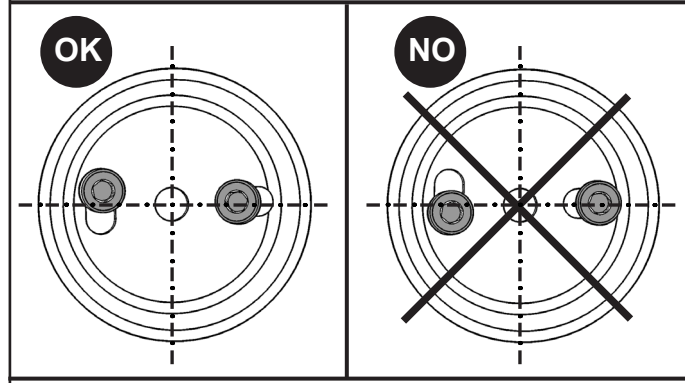
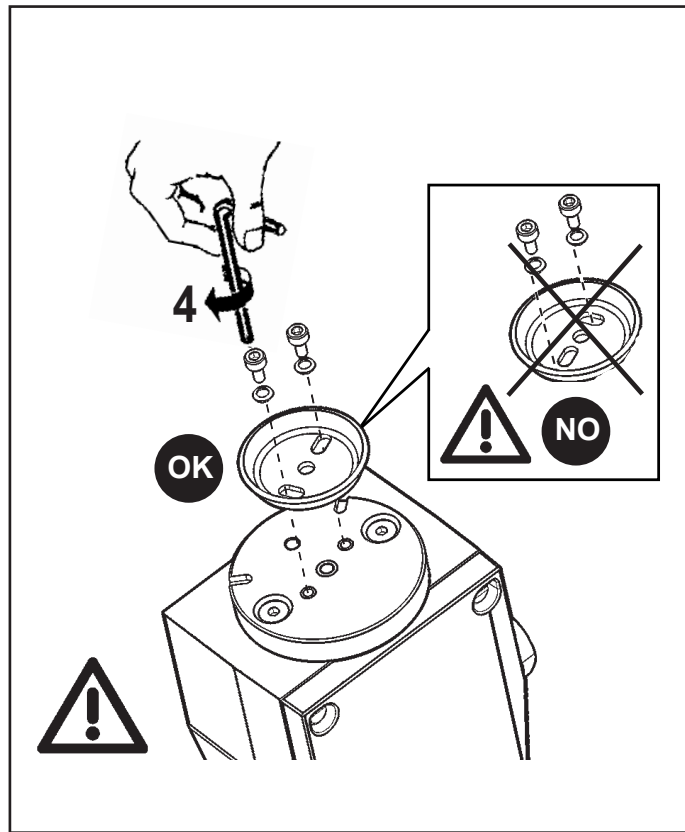
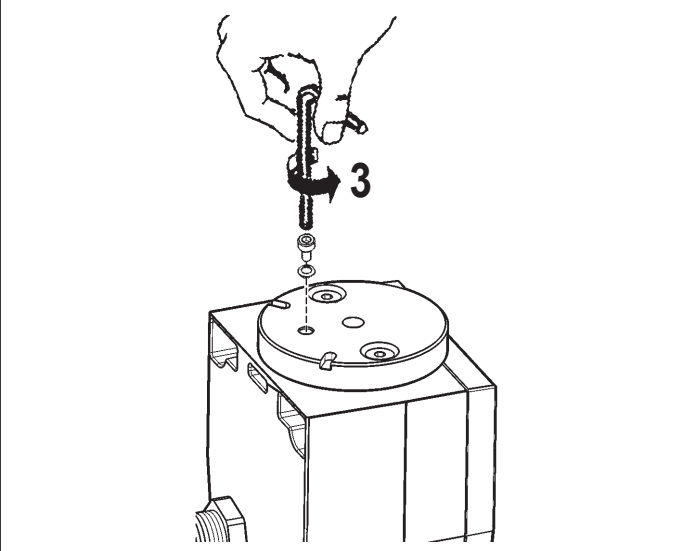
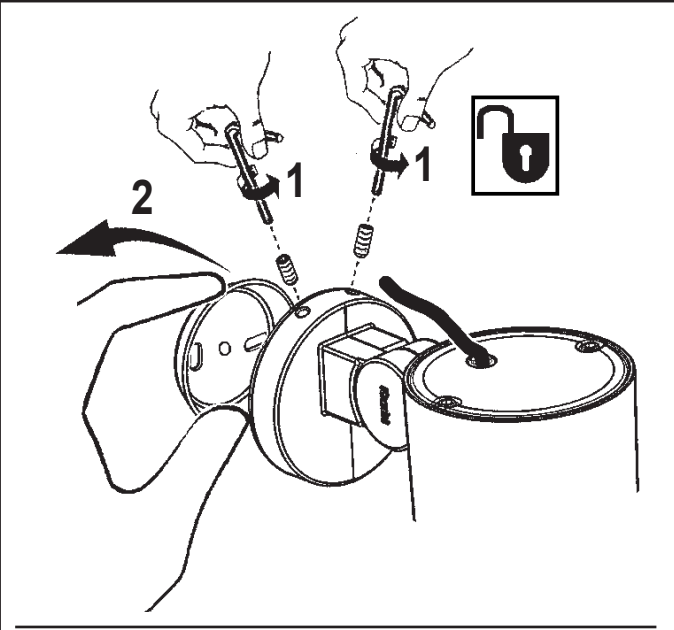
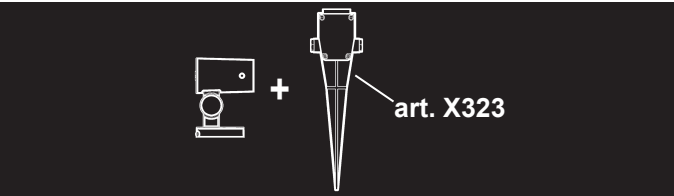

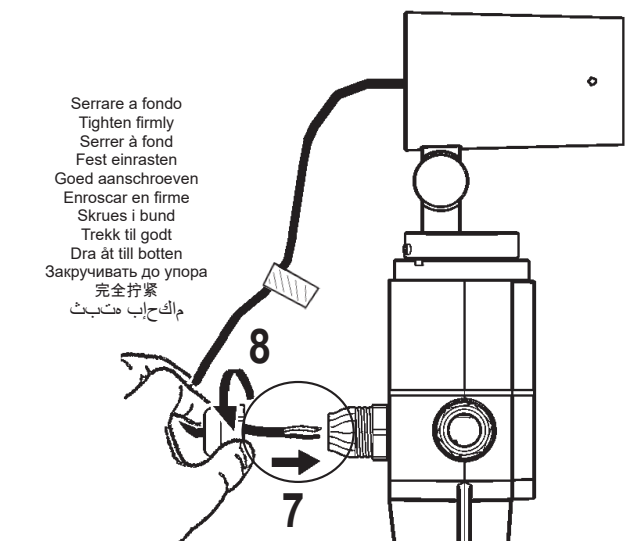
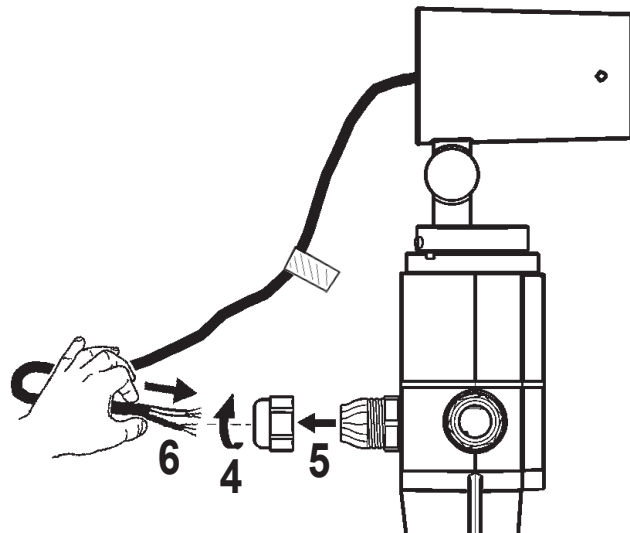
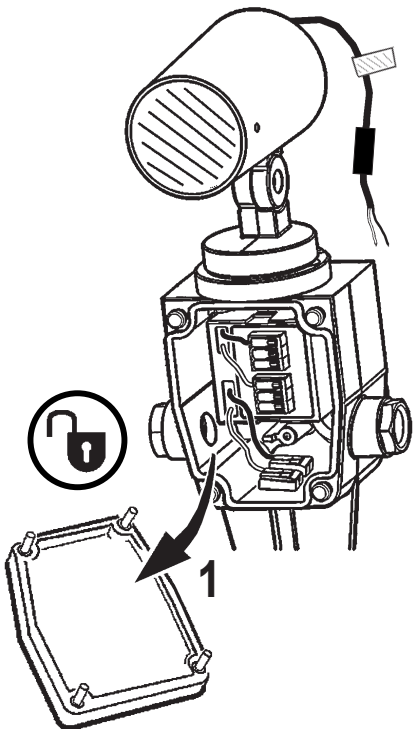
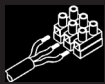

Serrare a fondo
 Tighten firmly
 Serrer à fond
 Fest einrasten
 Goed aanschroeven
 Enroscar en firme
 Skrues i bund
 Trekk til godt
 Dra åt till botten
 Закручивать до упора
 完全拧紧
 مالح اإب متكبث

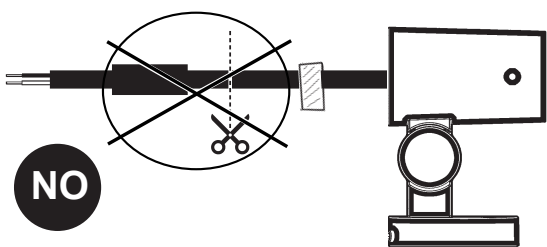
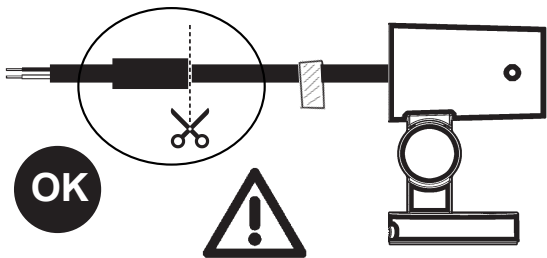
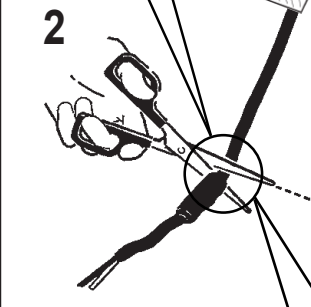
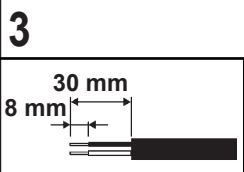
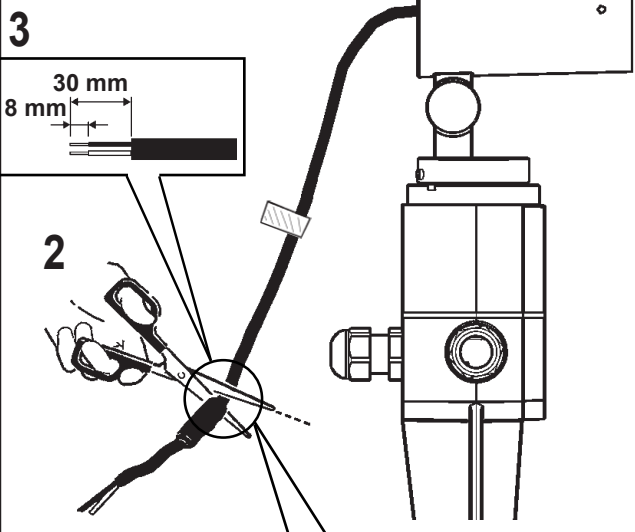

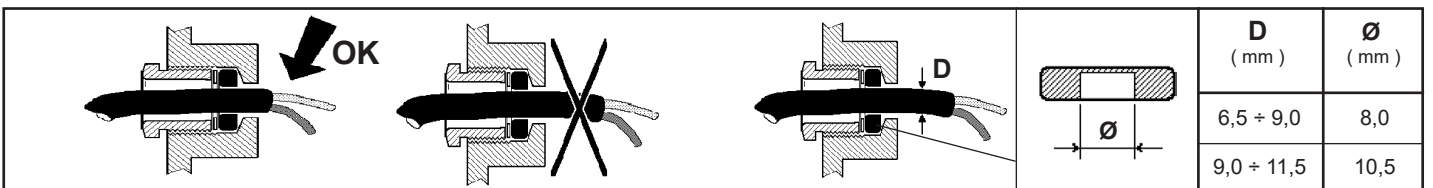
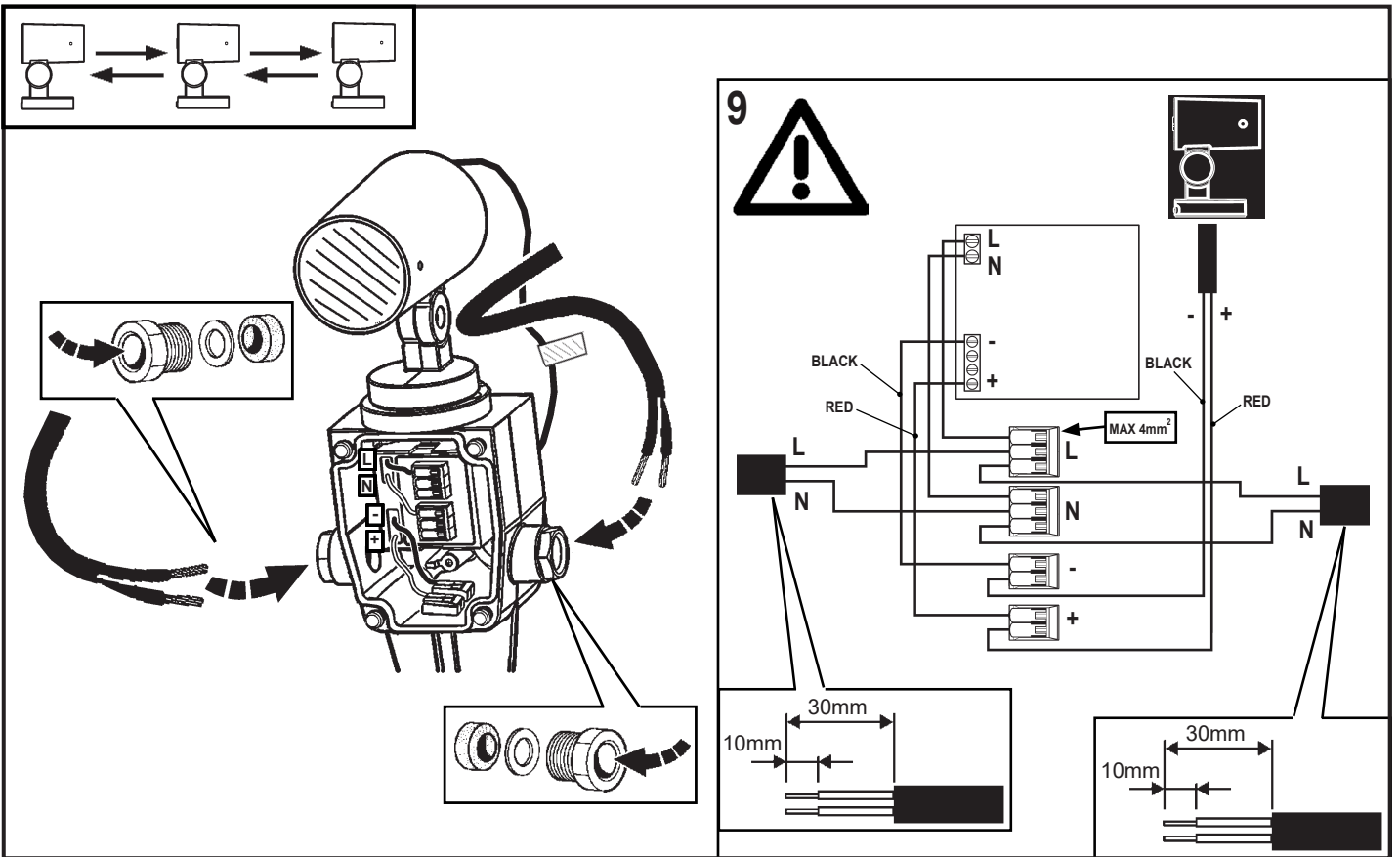
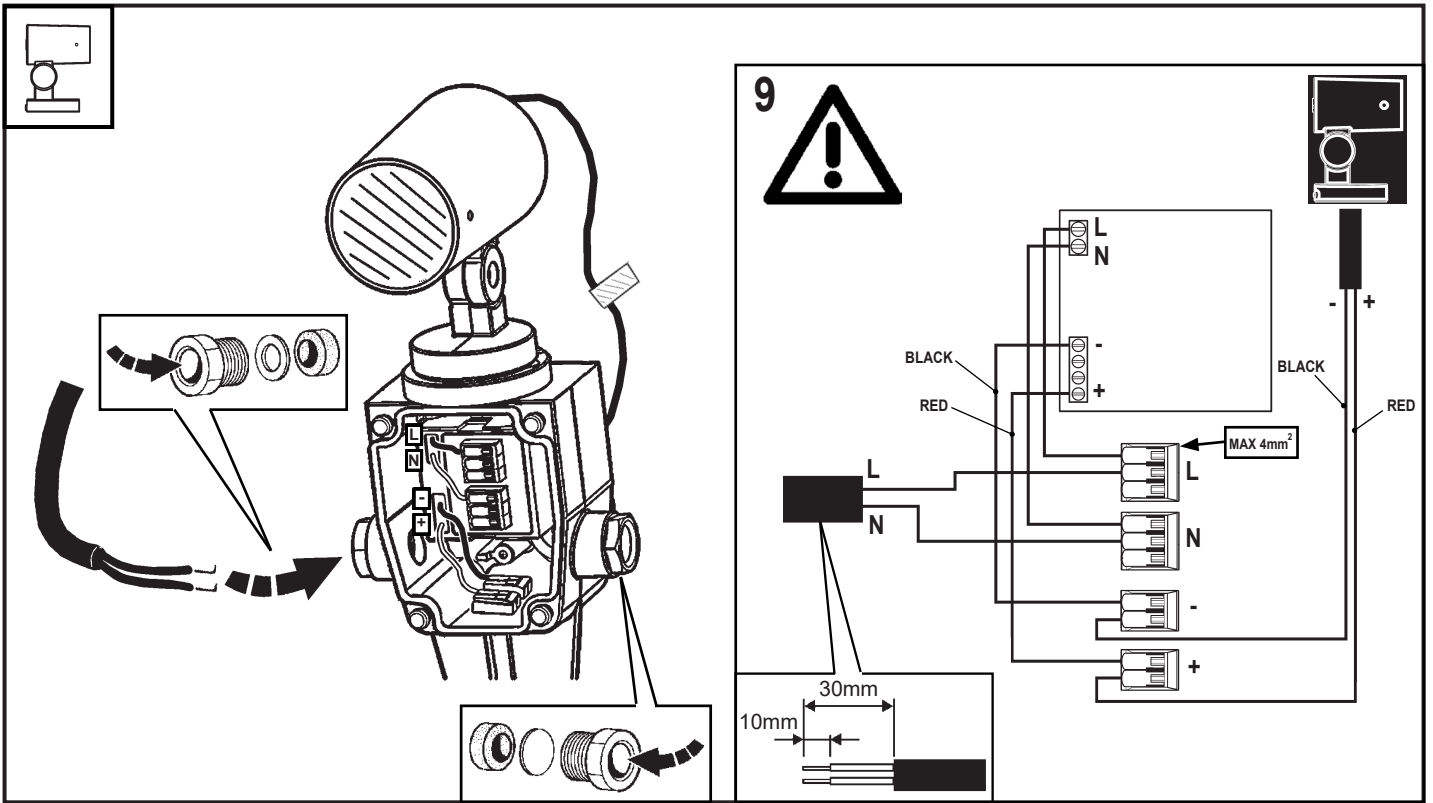

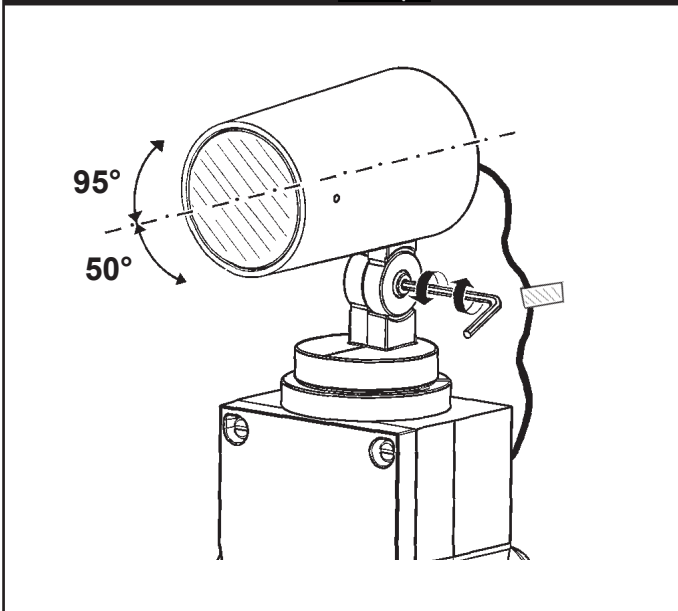
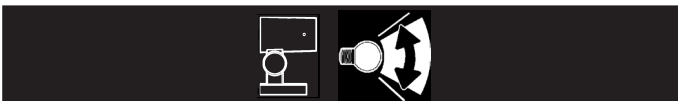
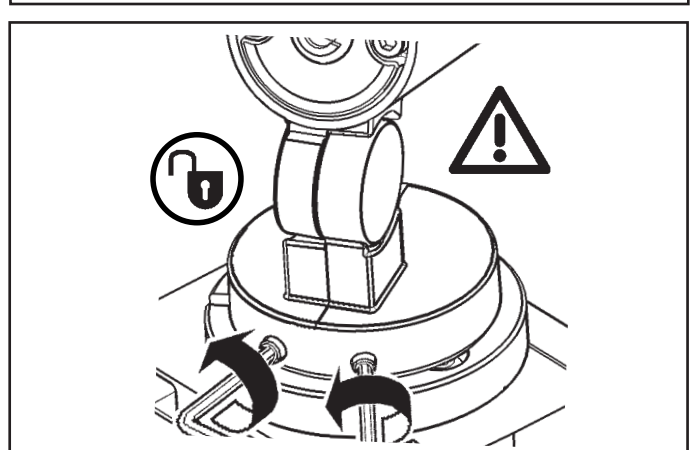
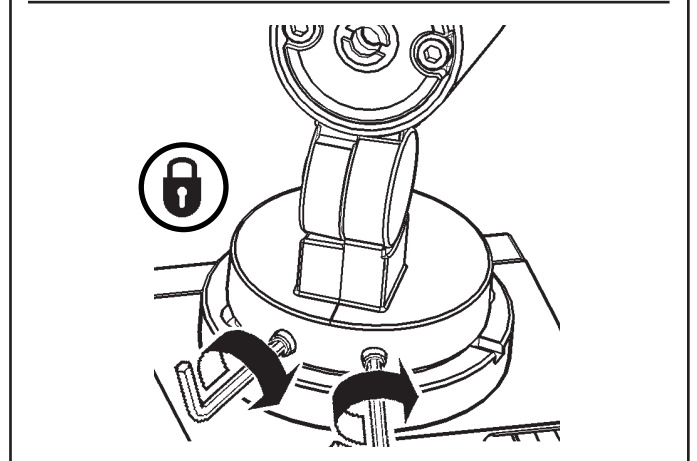
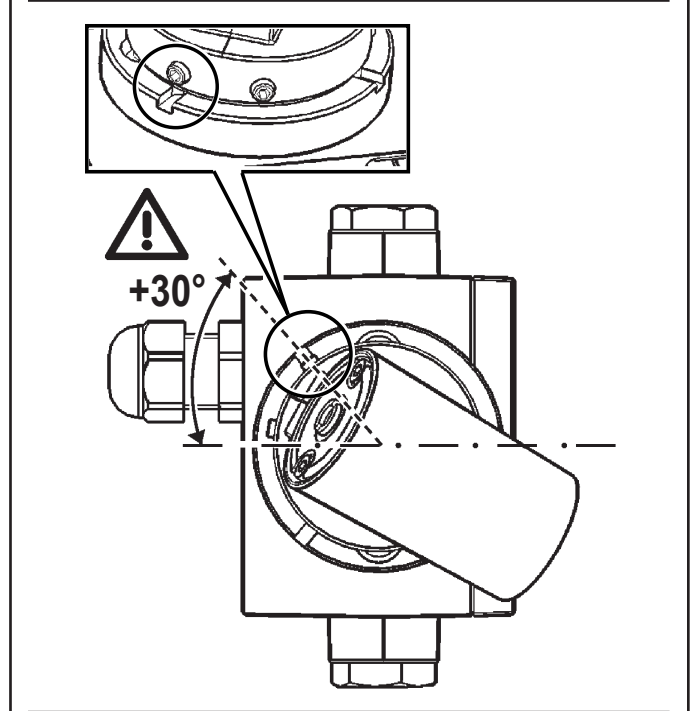
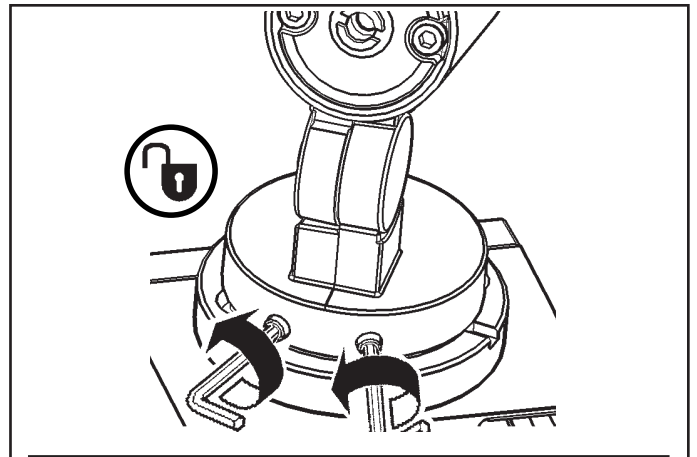
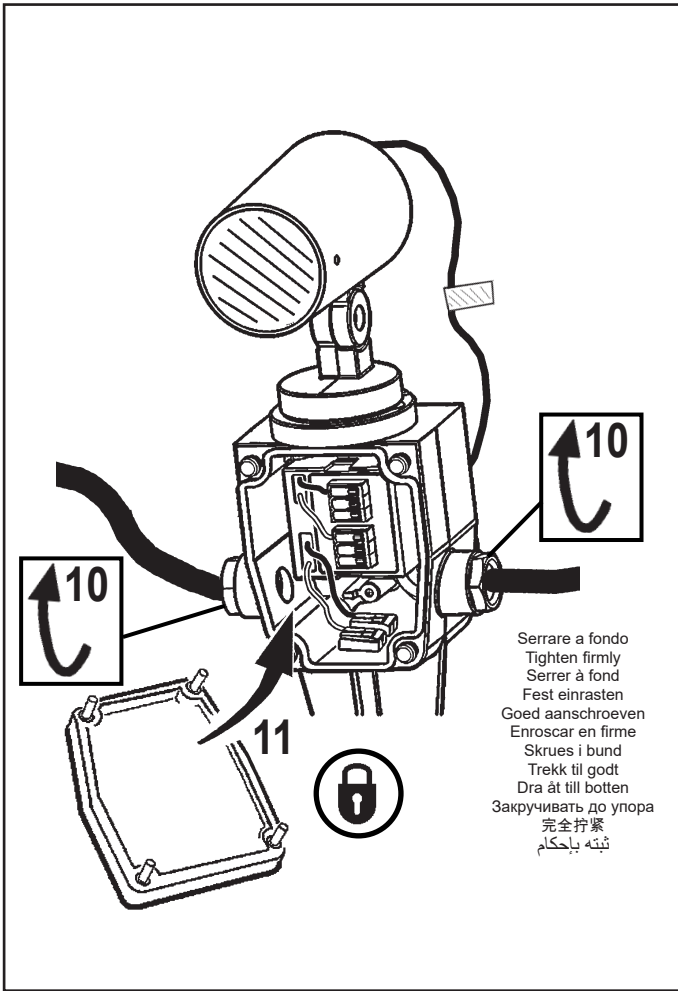

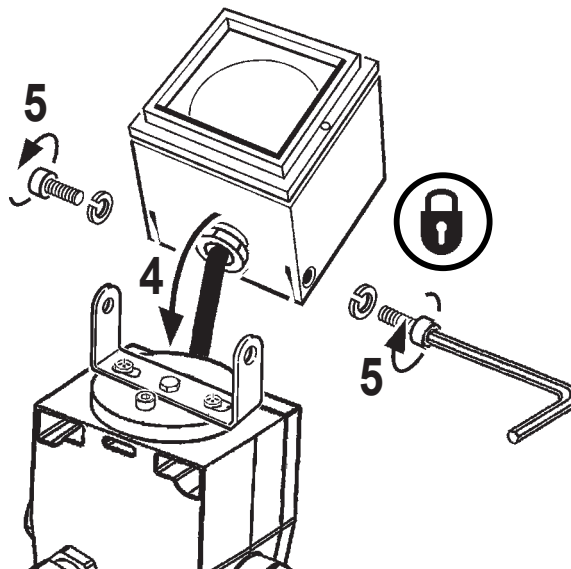
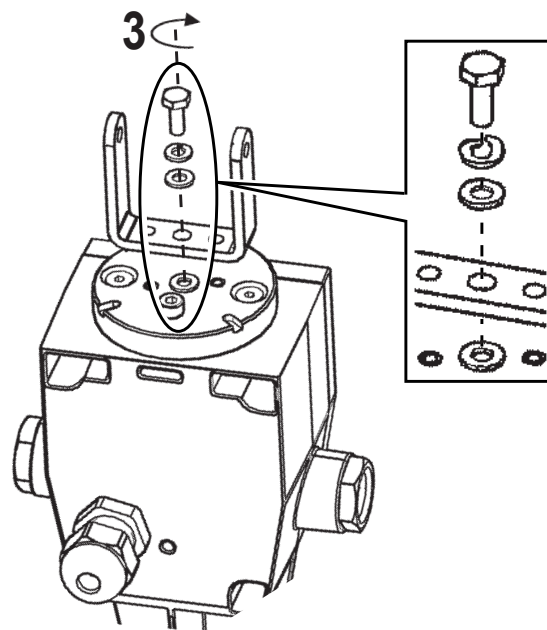
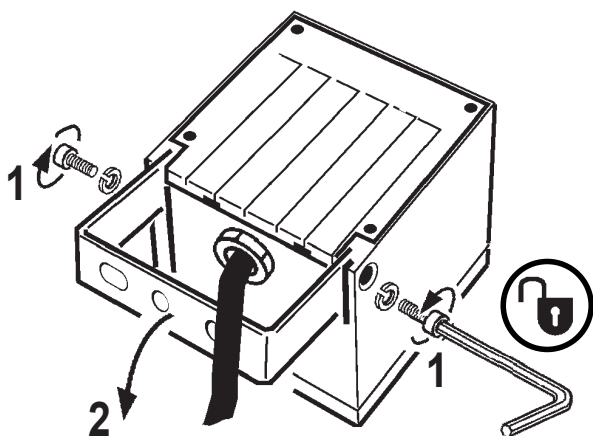
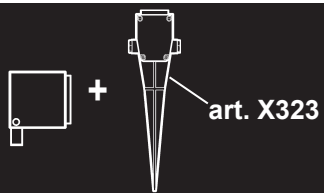
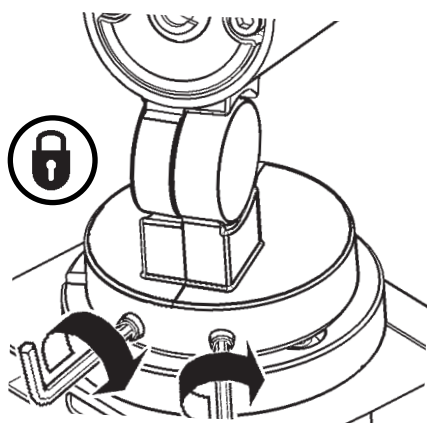
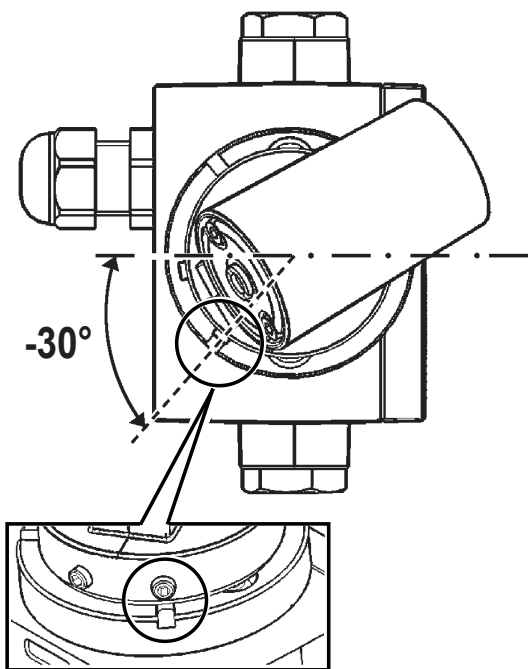

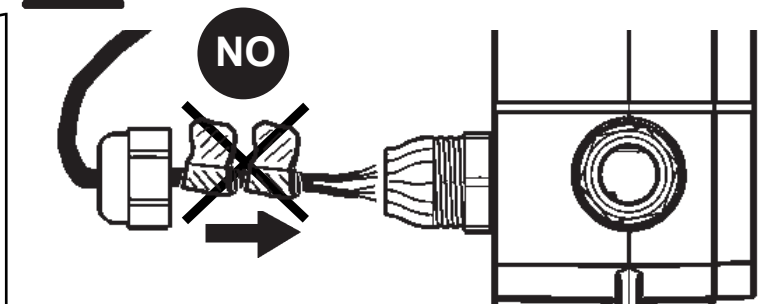
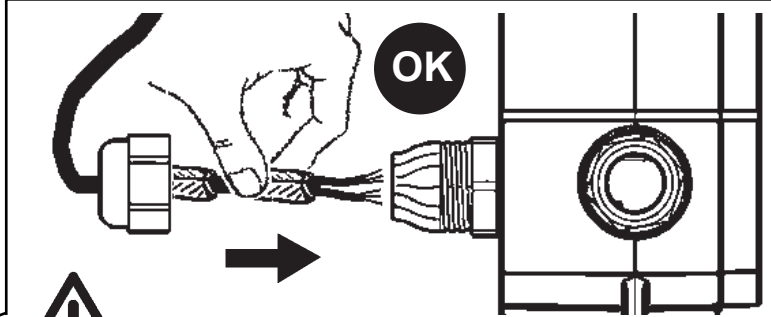
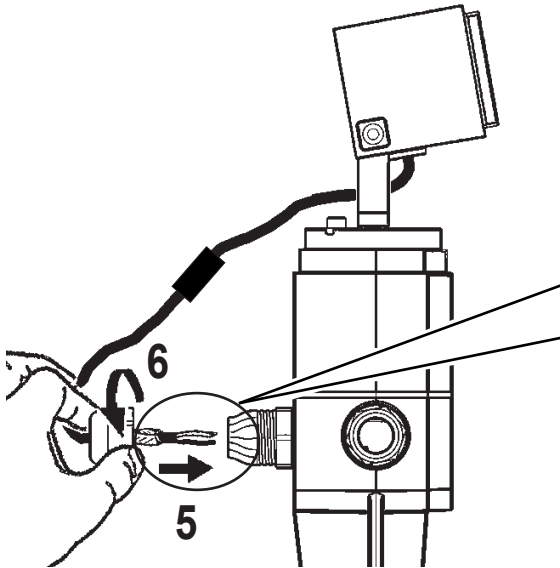
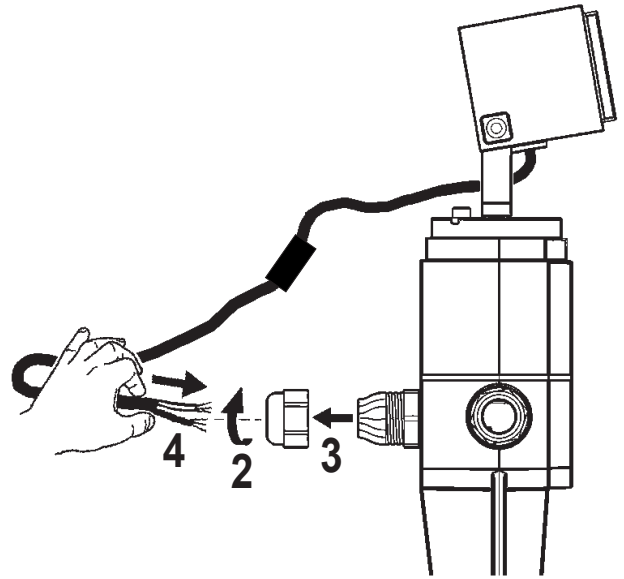
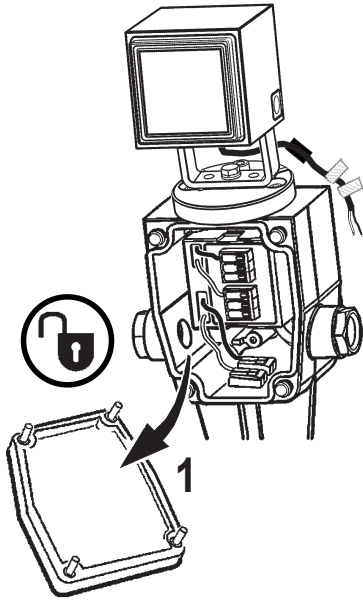
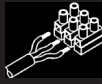

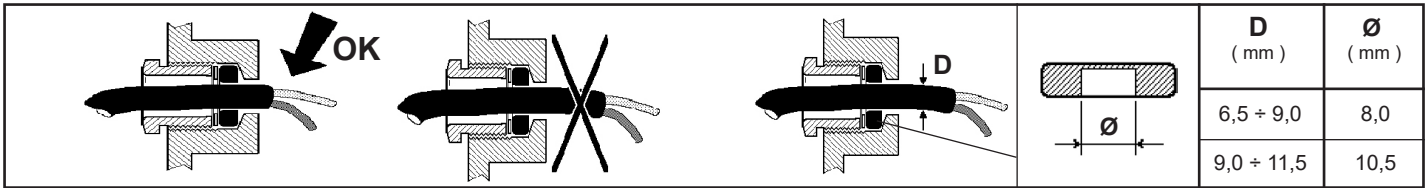
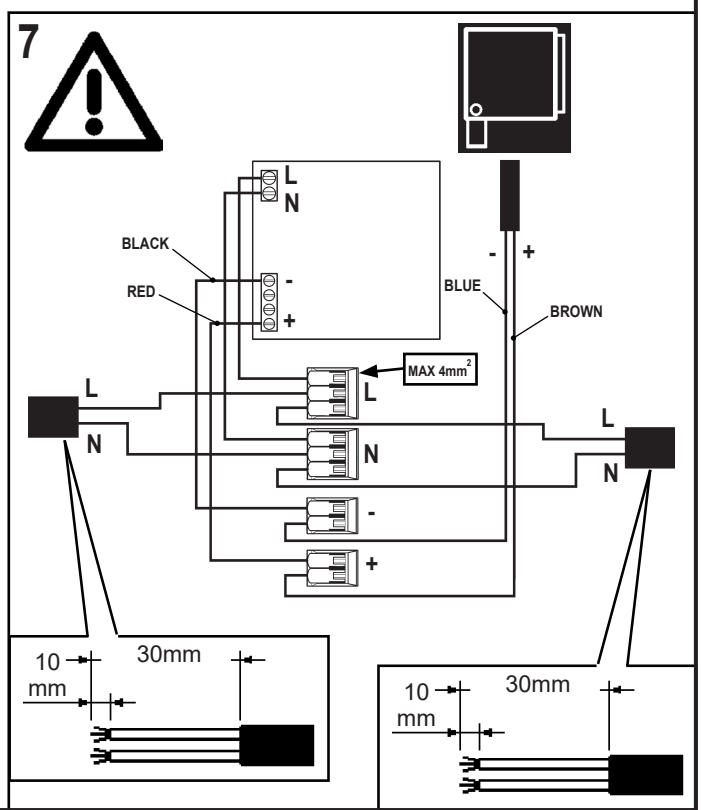
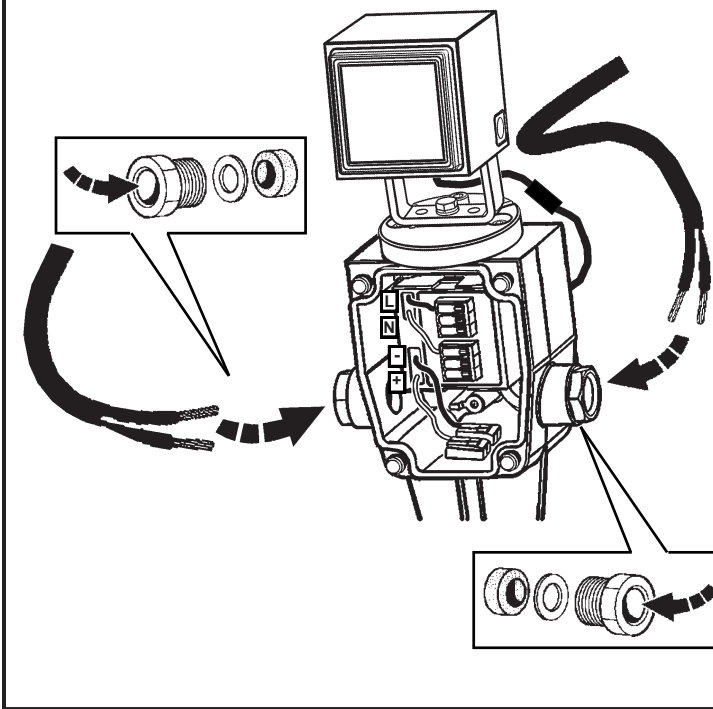
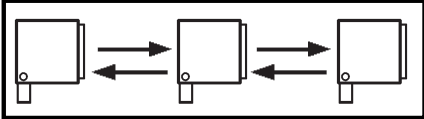
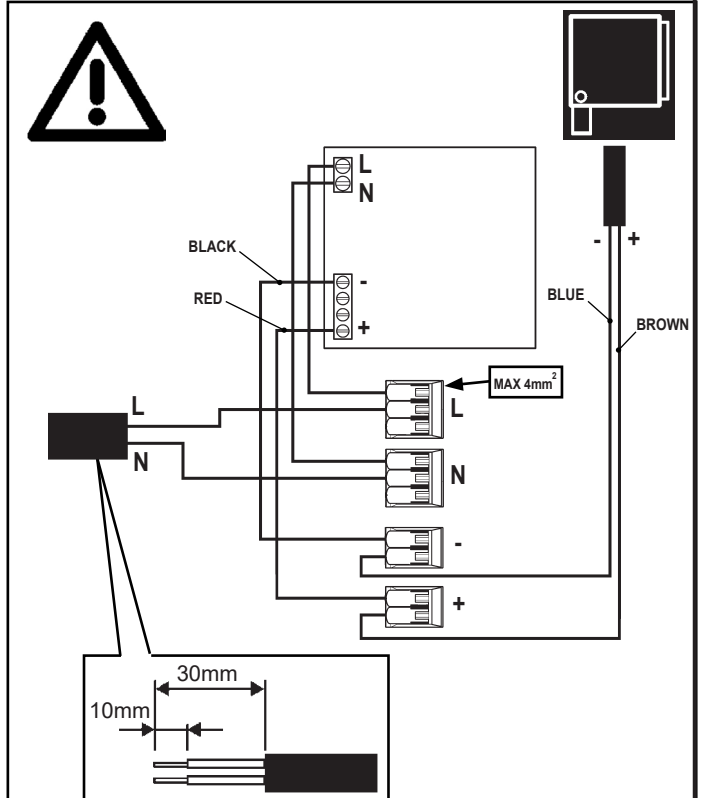
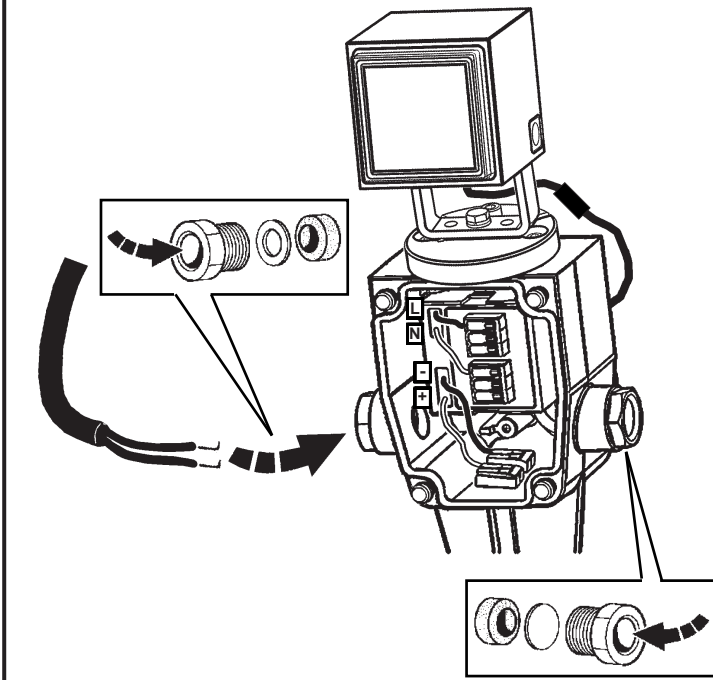
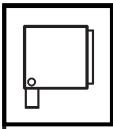

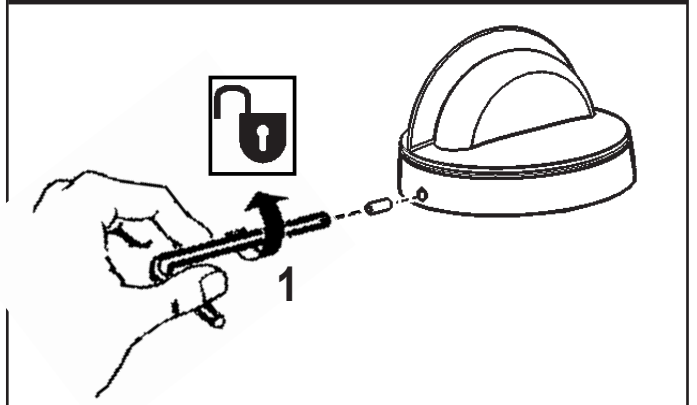
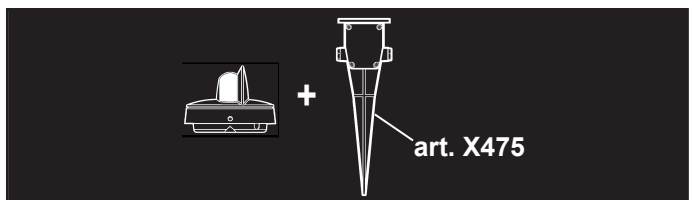
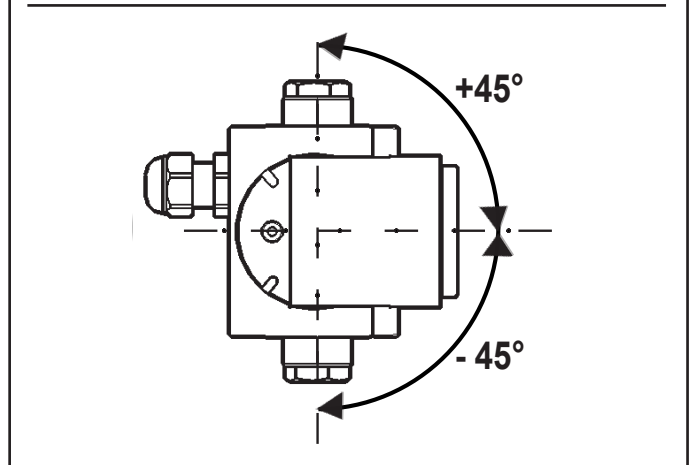
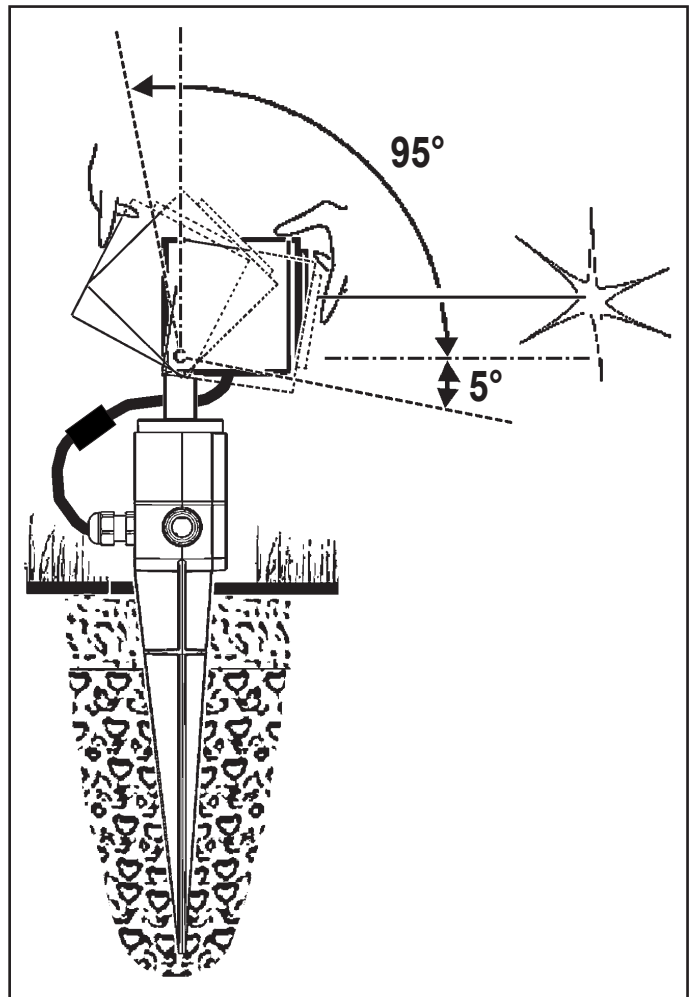
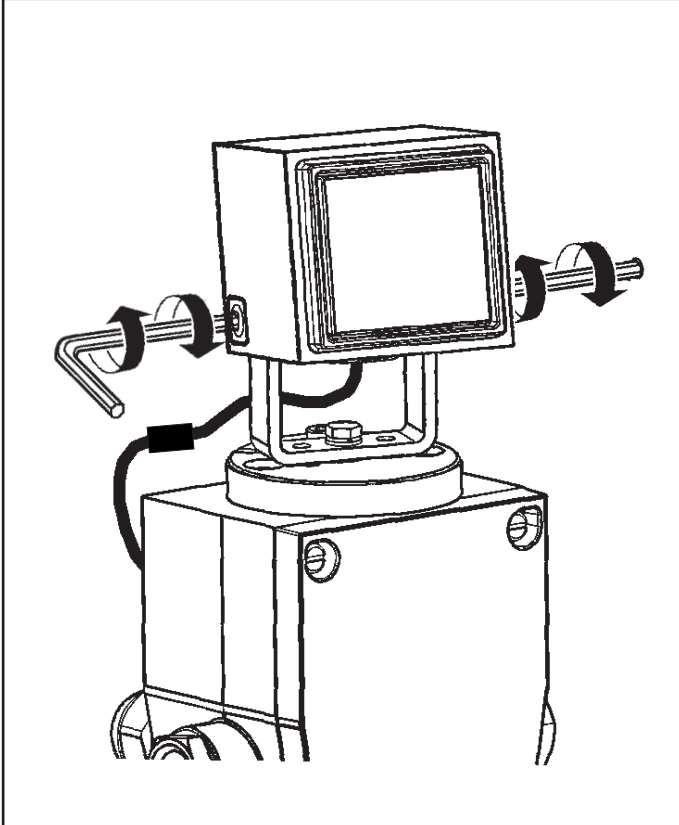
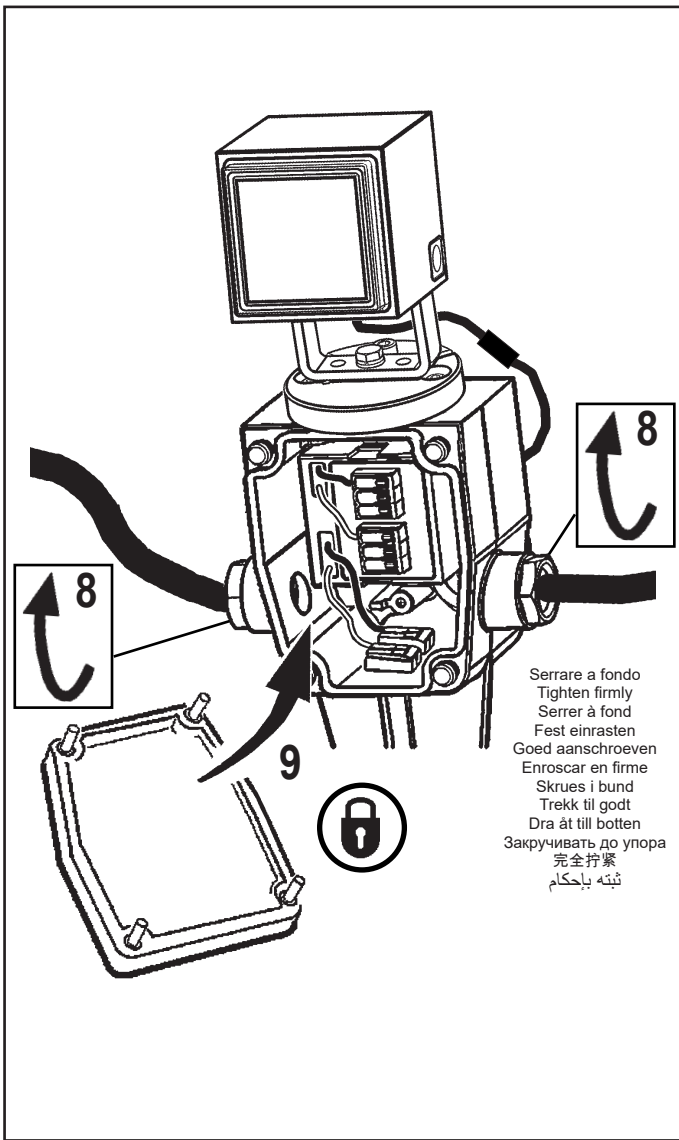

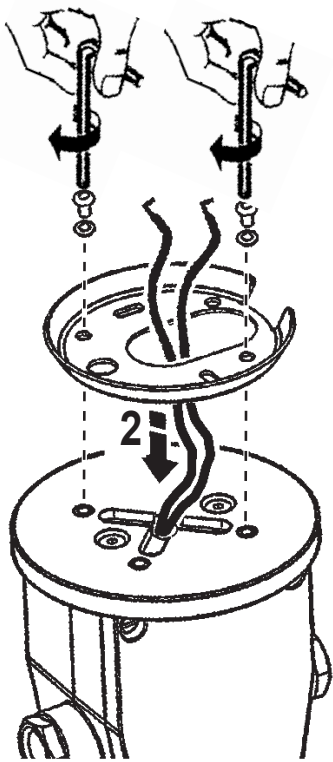

STAGNARE - COAT WITH
TIN ETAMER - VERZINNEN
VERTINNEN - ESTANAR
FORSEGLE - LÖD
ЛУЖЕНЫЕ
錫焊

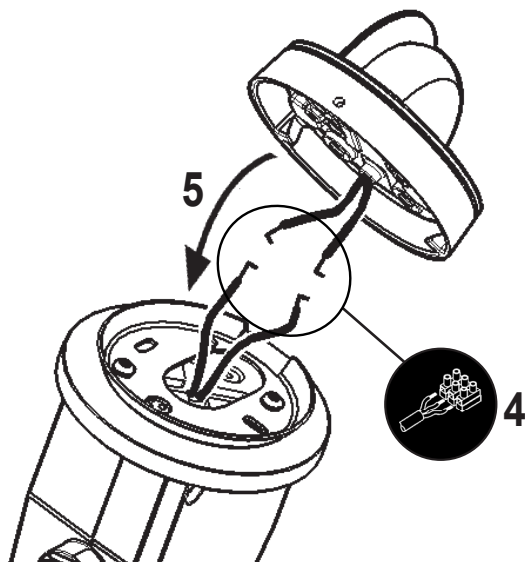
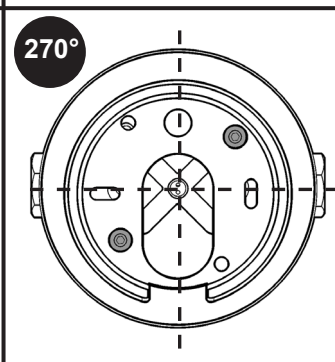
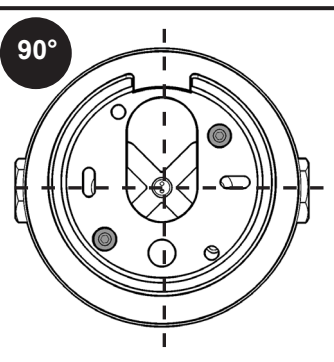
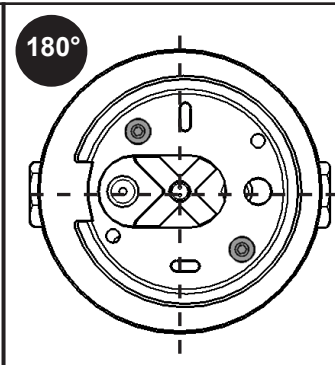
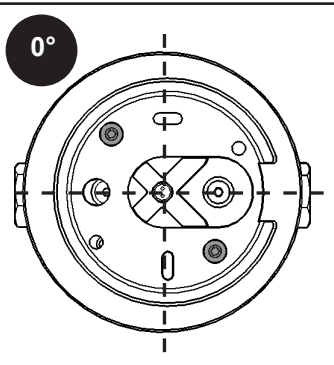
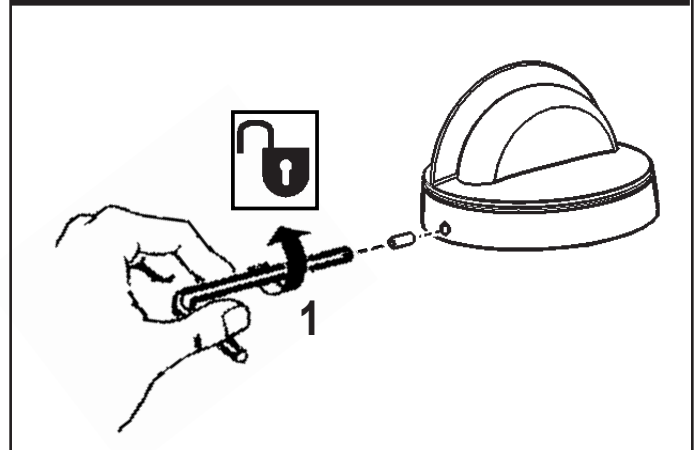
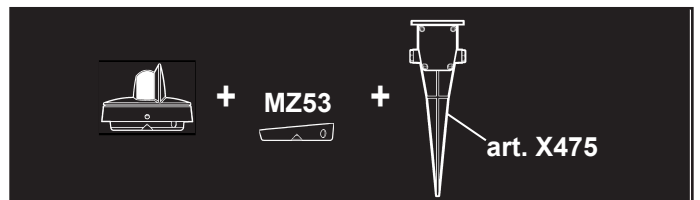
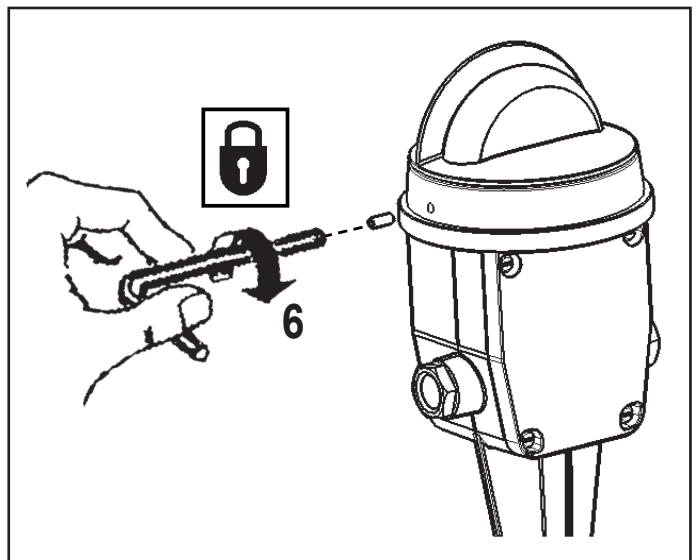
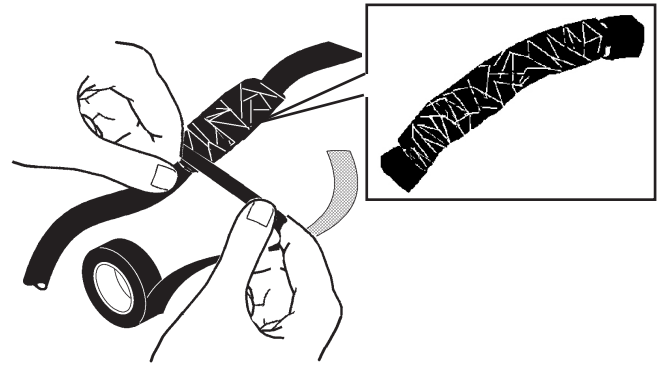
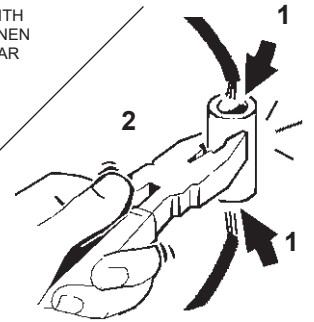

MZ53



2

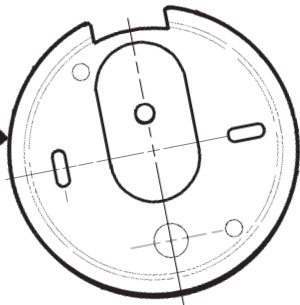

art. MZ53

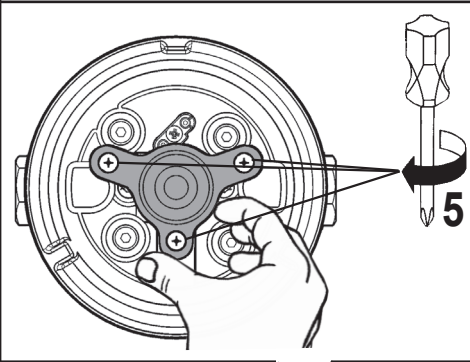
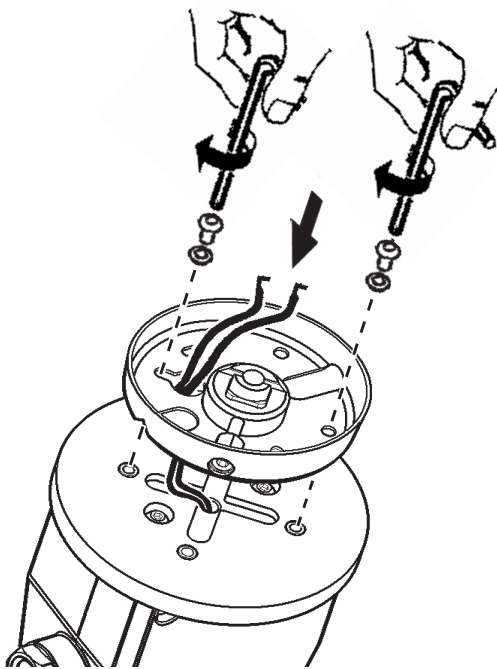
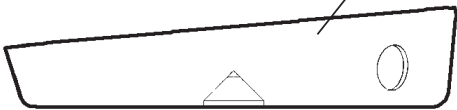

6

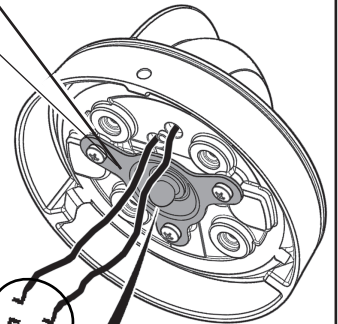

art. MZ53



STAGNARE - COAT WITH TIN
TIN ETAMER - VERZINNEN
VERTINNEN - ESTANAR
FORSEGLE - LÖD
ЛУЖЕНЫЕ
錫焊
الم

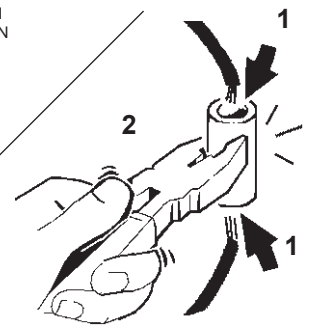
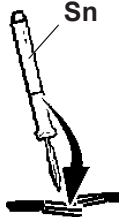

0°

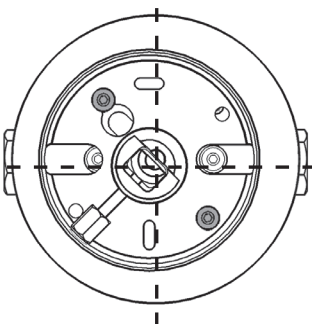

90°

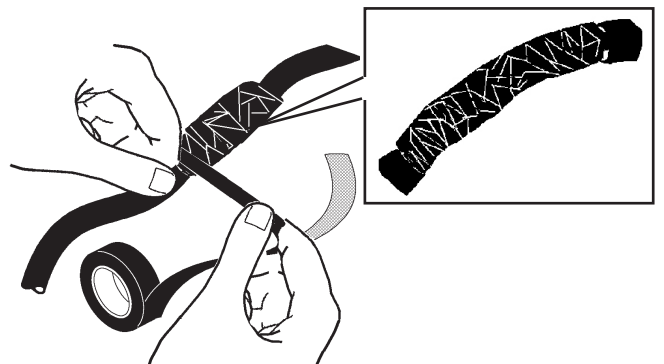
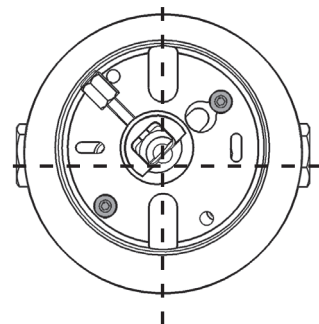

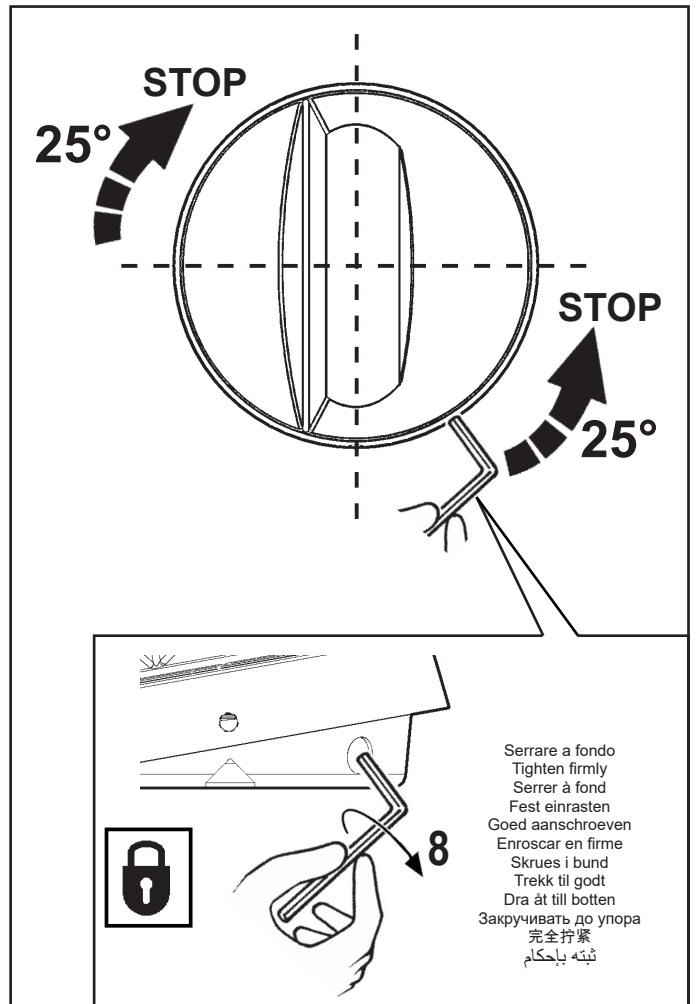
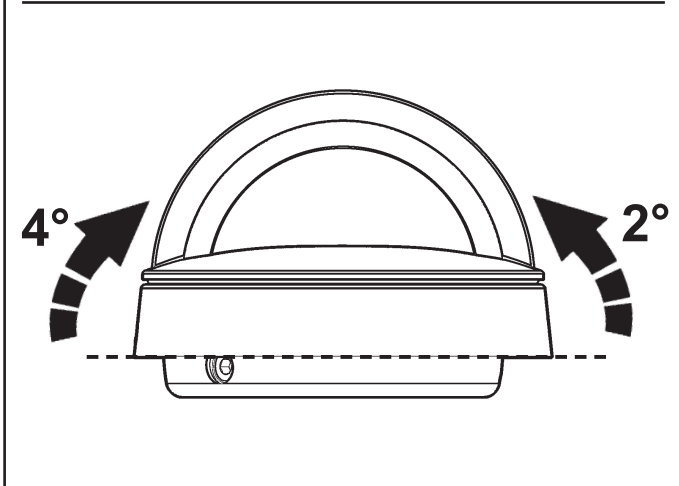
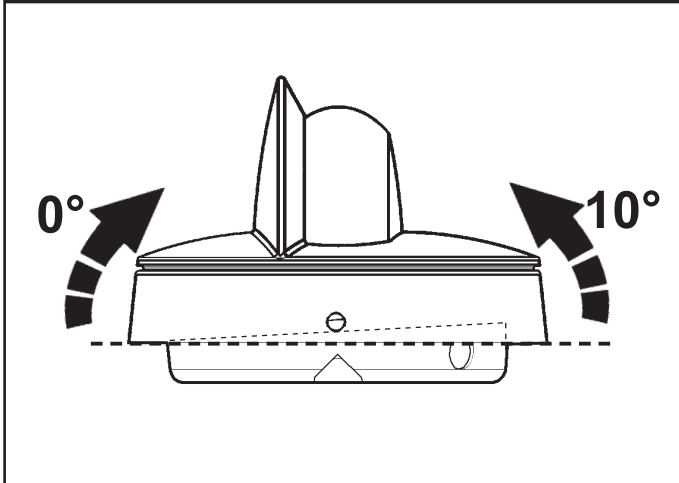
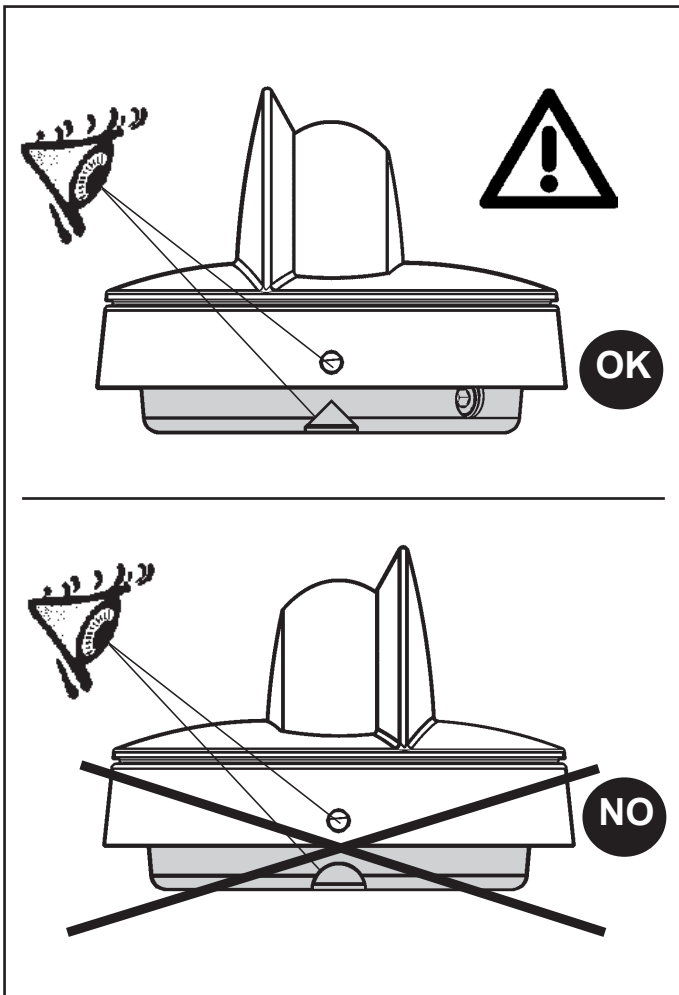

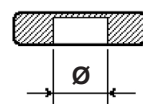
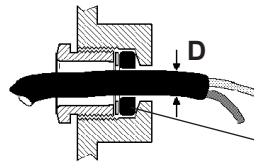
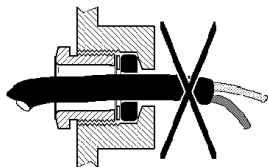
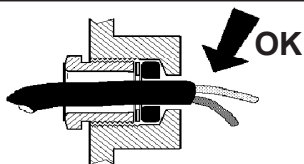
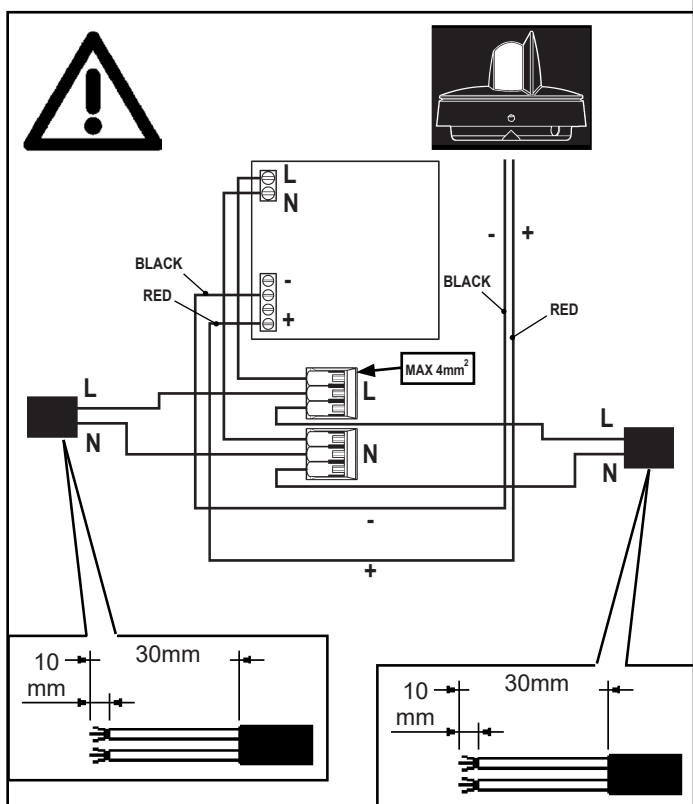
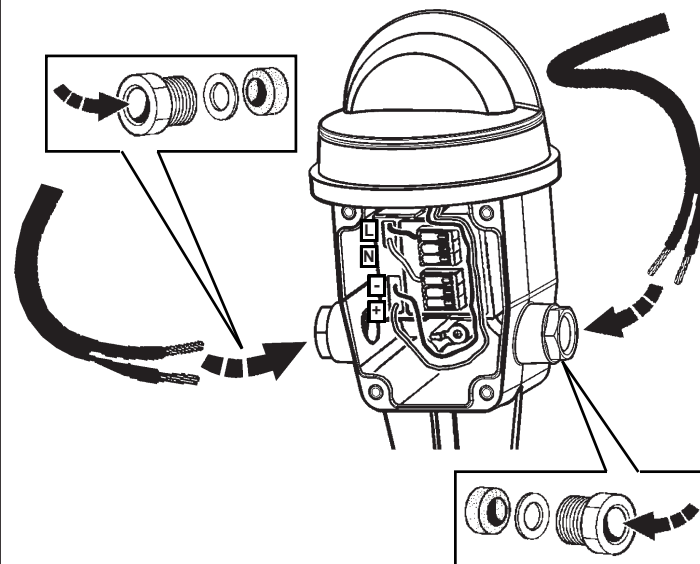
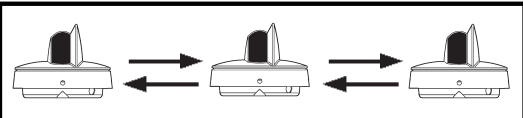
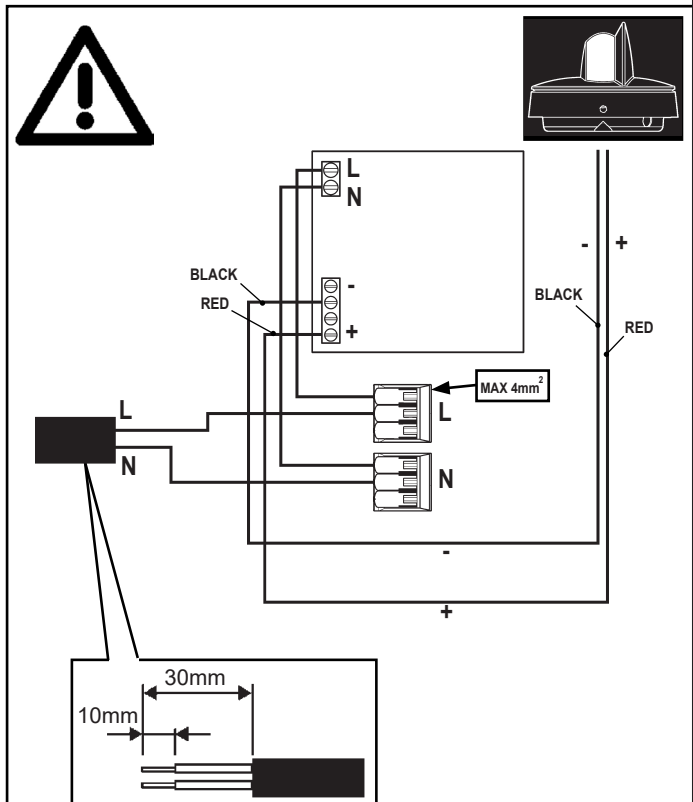
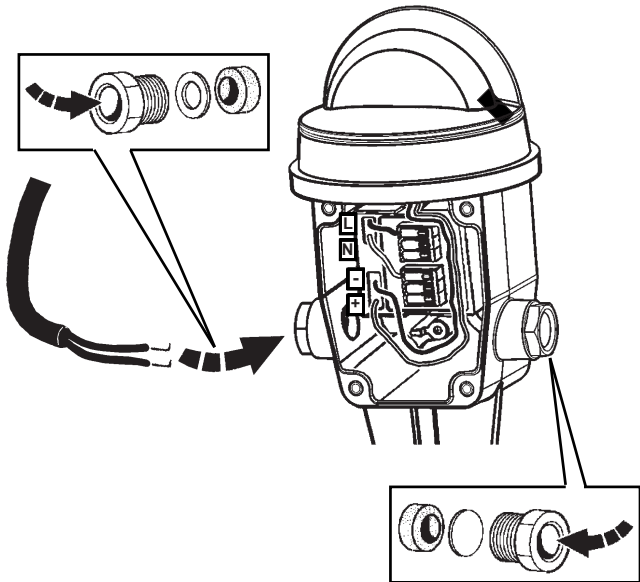
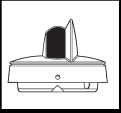
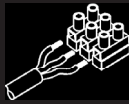

D (mm)	Ø (mm)
6,5 ÷ 9,0	8,0
9,0 ÷ 11,5	10,5