

LINEALUCE 27 SURFACE Remote 24V

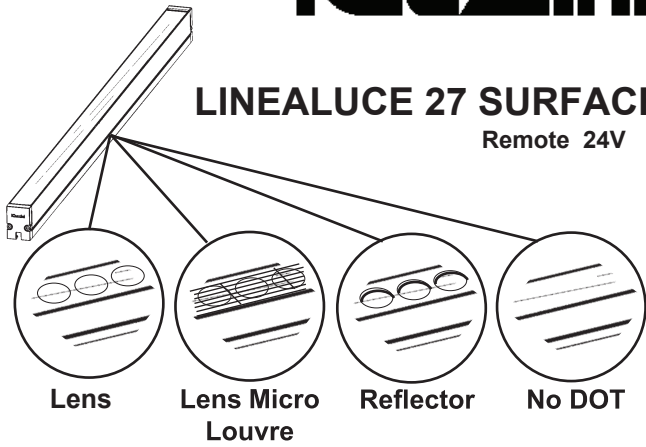

EN WARNING:

THE SAFETY OF THIS FIXTURE IS GUARANTEED ONLY IF YOU COMPLY WITH THESE INSTRUCTIONS; REMEMBER TO CONSERVE IN A SAFE PLACE.

FR ATTENTION:

LA SECURITE DE L'APPAREIL N'EST GARANTIE QU'EN CAS D'UTILISATION CORRECTE DES INSTRUCTIONS SUIVANTES; IL FAUT PAR CONSEQUENT LES CONSERVER.

ES ATENCION:

LA SEGURIDAD DEL APARATO SE GARANTIZA SOLO CUMPLIENDO CUIDADOSAMENTE LAS SIGUIENTES INSTRUCCIONES; POR ELLO, ES NECESARIO CONSERVARLAS.

IT ATTENZIONE:

LA SICUREZZA DELL'APPARECCHIO E' GARANTITA SOLO CON L'USO APPROPRIATO DELLE SEGUENTI ISTRUZIONI; PERTANTO E' NECESSARIO CONSERVARLE.

EN Install in accordance with National electric code, local and federal code specification.

FR Installer ce produit en conformité avec le code électrique national et les spécifications du code local et fédéral.

ES Instalar el producto respetando las normas eléctricas nacionales y las especificaciones de las normas locales y federales.

IT Installare questo conformità con il national electrical code e le specifiche del codice locale e federale.

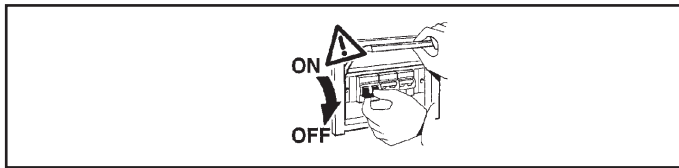

EN N.B.: WHEN INSTALLING THE SYSTEM, STRICTLY COMPLY WITH ALL REGULATIONS ON INSTALLATION IN FORCE.

FR N.B.: LORS DE L'INSTALLATION DU SYSTEME VEUILLEZ RESPECTER RIGOREUSEMENT LES NORMES EN VIGUEUR EN LA MATIERE.

ES N.B.: DURANTE LA INSTALACION DEL SISTEMA RESPETAR E SCRUPULOSAMENTE LAS NORMAS DE INSTALACION VIGENTES.

IT N.B.: DURANTE L'INSTALLAZIONE DEL SISTEMA RISPETTARE SCRUPOLOSAMENTE LE NORME IMPIANTISTICHE VIGENTI.

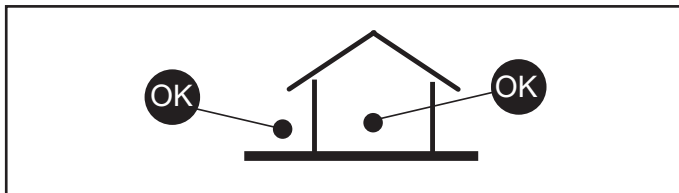

EN DO NOT MOUNT THE PRODUCT ON PLASTER BOARD

FR NE MONTEZ PAS LE PRODUIT SUR UNE PLAQUE DE PLÂTRE

ES NO MONTE EL PRODUCTO EN PLACAS DE YESO

IT NON MONTARE IL PRODOTTO SU CONTROSOFFITO

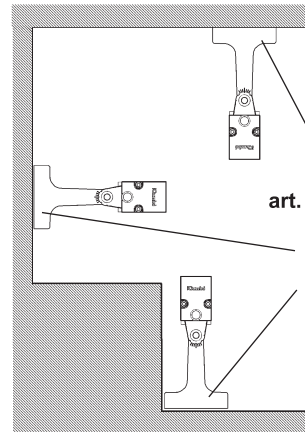
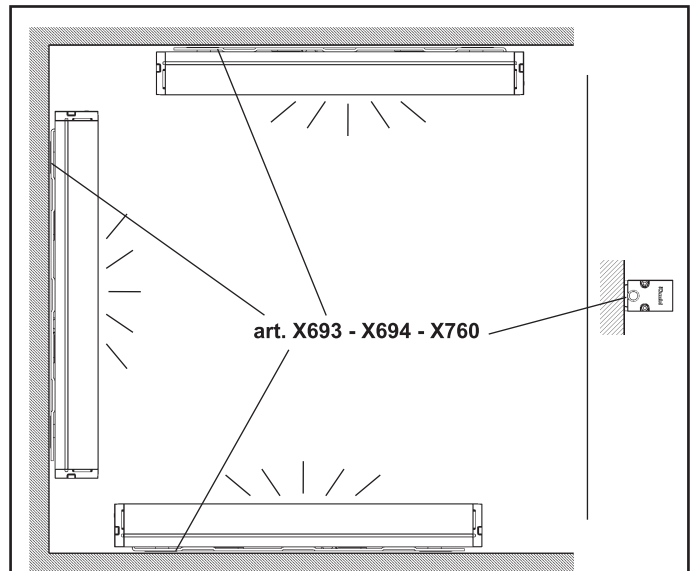

art. X688 - X770
 X771 - X772

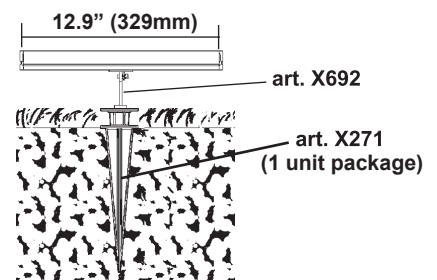
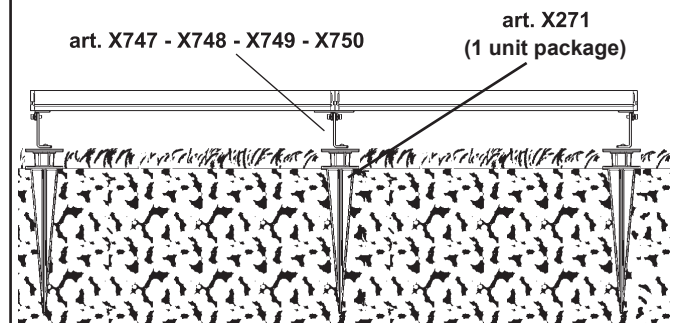
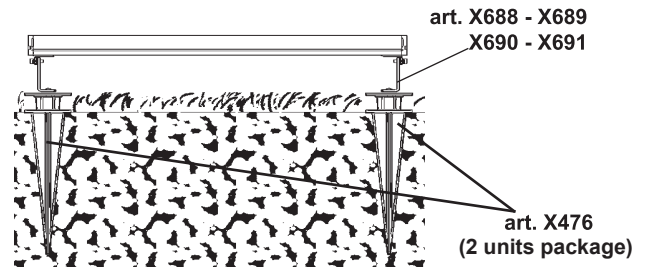
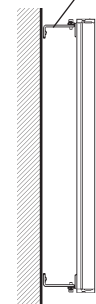

EN All installation positions must comply with those illustrated. In the event of any doubt, contact iGuzzini.

FR Pour les positions d'installation, se conformer aux positions illustrées ; contacter la société iGuzzini en cas de nécessité

ES Respetar las posiciones de instalación ilustradas y, en caso de duda, contactar con iGuzzini

IT Per le posizioni di installazione, attenersi a quelle illustrate, eventualmente contattare la iGuzzini.



These optics are not recommended for wall lighting



ELLIPTICAL
ILL27S-XX-BO-XXX-ELL

- S977-S978
- S979-S980
- S981-S982
- S983-S984
- S985-S986
- S987-S988
- SB00-SF57
- SF65



SPOT
ILL27S-XX-BO-XXX-SP

- S965-S966
- S967-S968
- S969-S970
- S971-S972
- S973-S974
- S975-S976
- SA99-SB08
- SF64



WIDE FLOOD
ILL27S-XX-BO-XXX-WF

- UE23 - UE30 - UE37
- UE44 - UE51 - UE58
- UE65 - UE72 - UE79
- UE86 - UE93 - UF00
- UF07 - UF14 - UF21
- UF28 - UF35 - UF42
- UF49 - UF56 - SA96
- SF55 - SF62 - SF69
- SB32



FLOOD
ILL27S-XX-BO-XXX-FL

- UE22 - UE29 - UE36
- UE43 - UE50 - UE57
- UE64 - UE71 - UE78
- UE85 - UE92 - UF09
- UF06 - UF13 - UF20
- UF27 - UF34 - UF41
- UF48 - UF55 - SA95
- SF54 - SF61 - SF68
- SF75



GENERAL LIGHTING
ILL27S-XX-BO-XXX-GL

- UE25 - UE32 - UE39
- UE46 - UE53 - UE60
- UE67 - UE74 - UE81
- UE88 - UE95 - UF02
- UF09 - UF16 - UF23
- UF30 - UF37 - UF44
- UF51 - UF58 - SA98
- SB07 - SB16 - SF71
- SB34

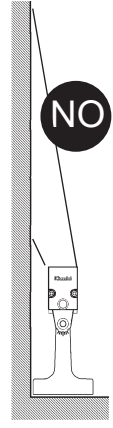

| ART. | L in (mm) |
|---|------------------------|
| UE19 - UE20 - UE21 - UE22 - UE23 - UE24 - UE25 - UE26 - UE27 - UE28 - UE29 UE30 - UE31 - UE32 - UE33 - UE34 - UE35 - UE36 - UE37 - UE38 - UE39 - UE40 UE41 - UE42 - UE43 - UE44 - UE45 - UE46 - UF50 - UF51 - UF52 - UF53 - UF54 UF55 - UF56 - UF57 - UF58 - UF59 - UF60 - UF61 - UF62 - UF63 - UF64 - UF65 UF66 - UF67 - UF68 - UF69 - UF70 - S965 - S966 - S967 - S968 - S977 - S978 S979 - S980 - SA92 - SA93 - SA94 - SA95 - SA96 - SA97 - SA98 - SA99 - SB00 ILL27S-01 | 12.9" (329) |
| UE47 - UE48 - UE49 - UE50 - UE51 - UE52 - UE53 - UE54 - UE55 - UE56 - UE57 UE58 - UE59 - UE60 - UE61 - UE62 - UE63 - UE64 - UE65 - UE66 - UE67 - UE68 UE69 - UE70 - UE71 - UE72 - UE73 - UE74 - UF71 - UF72 - UF73 - UF74 - UF75 UF76 - UF77 - UF78 - UF79 - UF80 - UF81 - UF82 - S969 - S670 - S671 - S972 S981 - S982 - S983 - S984 - SF51 - SF52 - SF53 - SF54 - SF55 - SF56 - SB07 SB08 - SF57 ILL27S-02 | 24.6" (625) |
| UE75 - UE76 - UE77 - UE78 - UE79 - UE80 - UE81 - UE82 - UE83 - UE84 - UE85 UE86 - UE87 - UE88 - UE89 - UE90 - UE91 - UE92 - UE93 - UE94 - UE95 - UE96 UE97 - UE98 - UE99 - UF00 - UF01 - UF02 - UF83 - UF84 - UF85 - UF86 - UF87 UF88 - UF89 - UF90 - UF91 - UF92 - UF93 - UF94 - S973 - S974 - S975 - S976 S985 - S986 - S987 - S988 - SF58 - SF59 - SF60 - SF61 - SF62 - SF63 - SB16 SF64 - SF65 ILL27S-03 | 36.2" (920) |
| UF03 - UF04 - UF05 - UF06 - UF07 - UF08 - UF09 - UF10 - UF11 - UF12 - UF13 UF14 - UF15 - UF16 - UF17 - UF18 - UF19 - UF20 - UF21 - UF22 - UF23 - UF24 UF25 - UF26 - UF27 - UF28 - UF29 - UF30 - UF95 - UF96 - UF97 - UF98 - UF99 UG00 - UG01 - UG02 - UG03 - UG04 - UG05 - UG06 - SF66 - SF67 - SB21 - SF68 SF69 - SF70 - SF71 ILL27S-04 | 47.8" (1216) |
| UF31 - UF32 - UF33 - UF34 - UF35 - UF36 - UF37 - UF38 - UF39 - UF40 - UF41 UF42 - UF43 - UF44 - UF45 - UF46 - UF47 - UF48 - UF49 - UF50 - UF51 - UF52 UF53 - UF54 - UF55 - UF56 - UF57 - UF58 - UG07 - UG08 - UG09 - UG10 - UG11 UG12 - UG13 - UG14 - UG15 - UG16 - UG17 - UG18 - SF72 - SF73 - SF74 - SF75 SB32 - SB33 - SB34 ILL27S-05 | 59.4" (1511) |

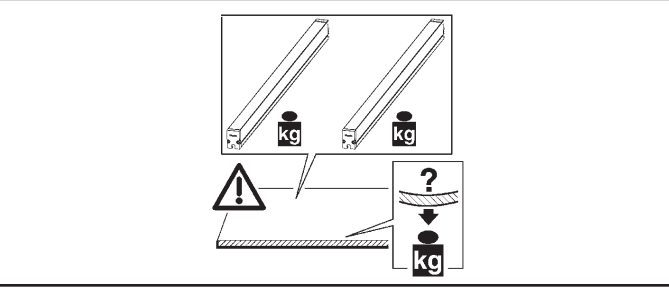

EN Any accessories or mechanical supports must be assembled before installing the product.

FR Les accessoires et les supports mécaniques doivent être assemblés avant d'installer le produit.

ES Ensamblar los accesorios y los soportes mecánicos antes de instalar el producto.

IT Gli accessori e i supporti meccanici devono essere assemblati prima di installare il prodotto.

EN Min space between units, 0.07" (2mm)

FR Espace min entre les unités 0,07" (2mm)

ES Espacio mínimo entre unidades, 0,07" (2mm)

IT Spazio min tra le unità, 0,07" (2mm)

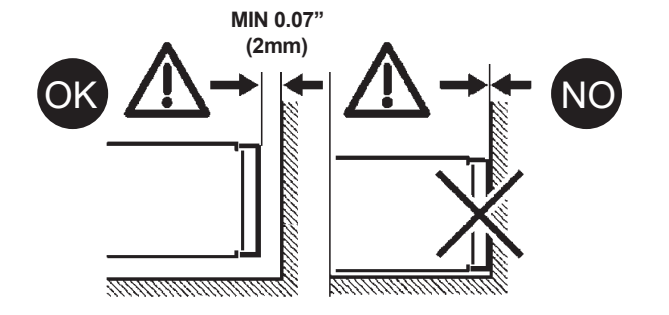
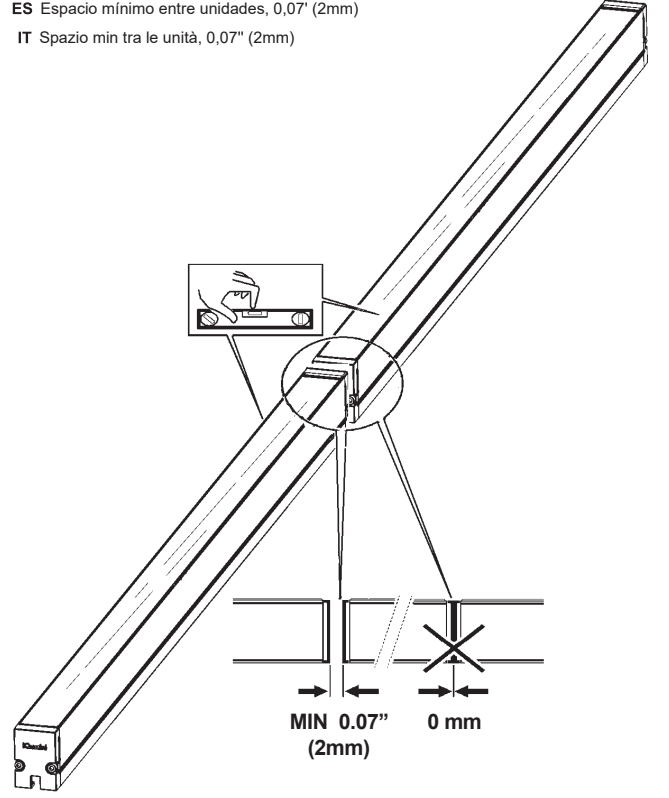

ACCESSORIES:
OPTICAL
PROTECTION PAGE 16

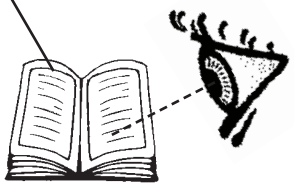

INSTRUCTION SHEET

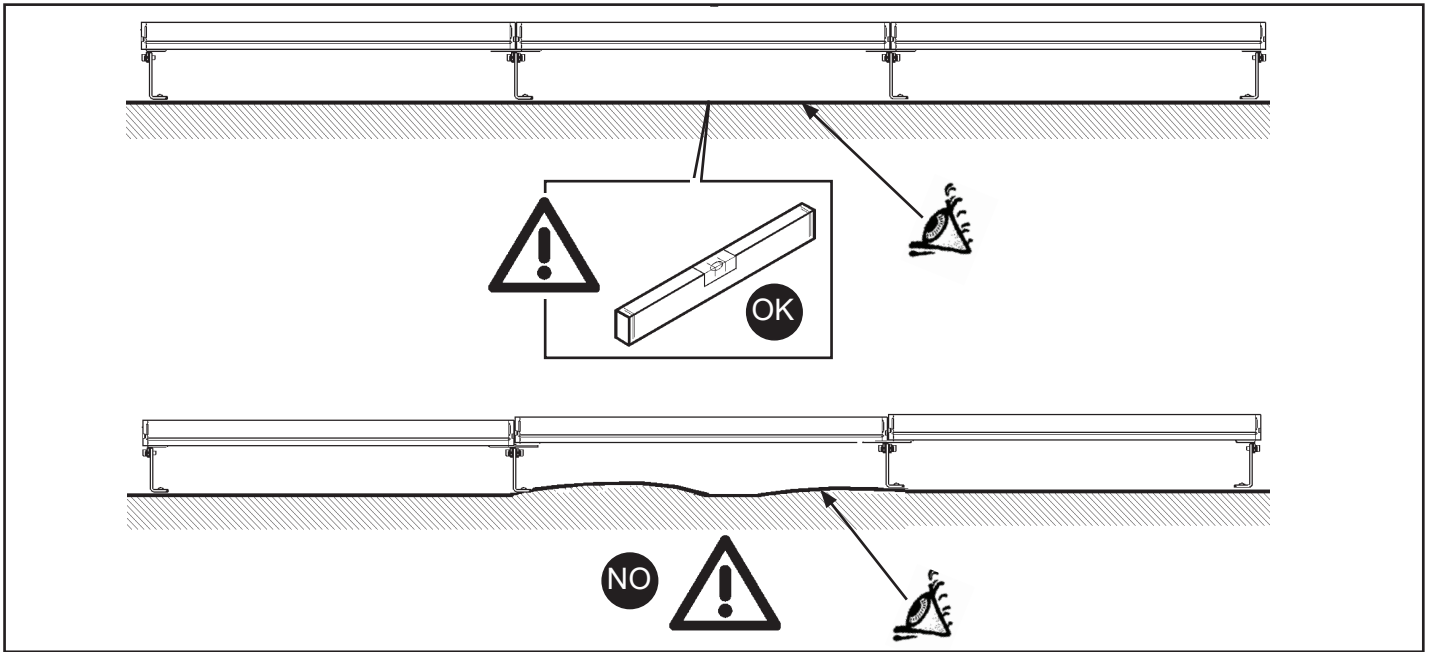

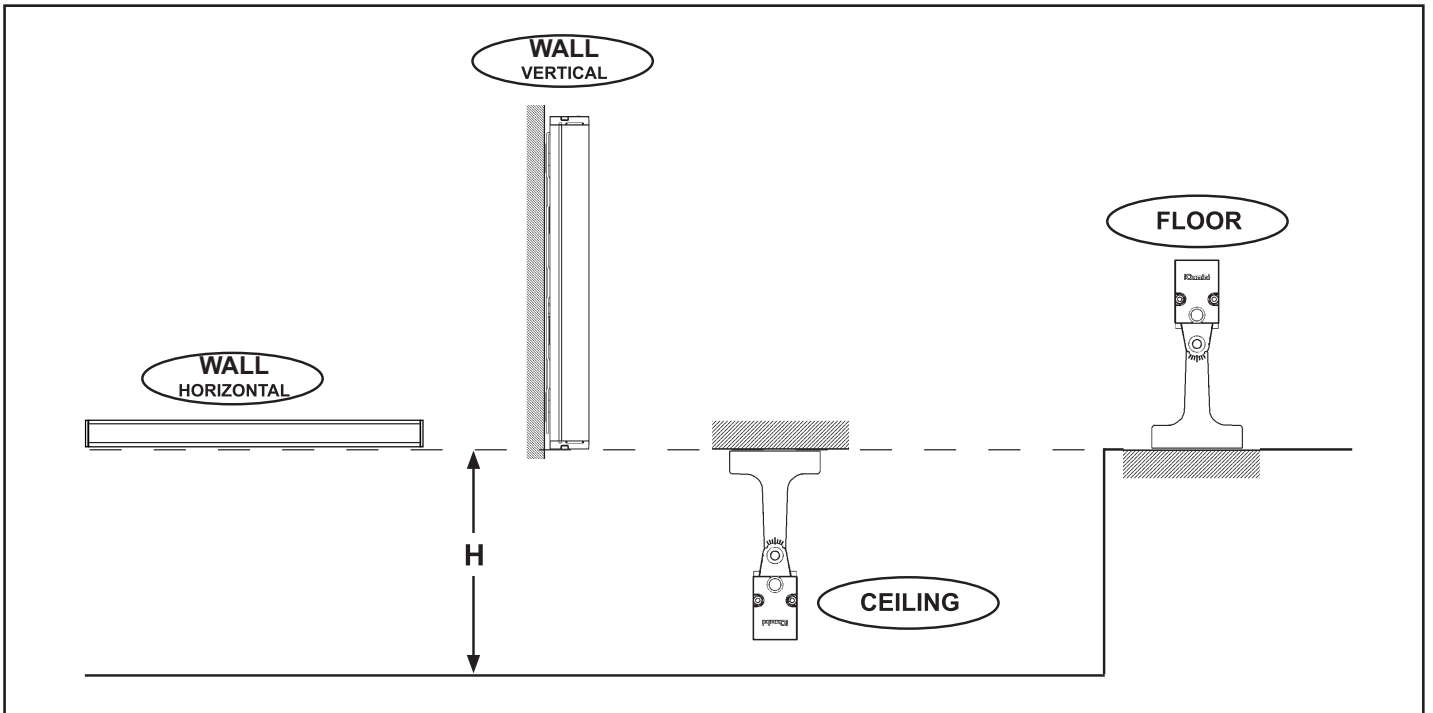

PERMITTED INSTALLATION POSITIONS - POSITIONS D'INSTALLATION AUTORISÉES
 POSICIONES DE INSTALACIÓN PERMITIDAS - POSIZIONI DI INSTALLAZIONE CONSENTITE

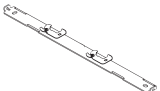
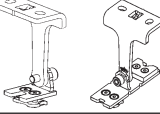

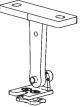
| ACCESSORIES art. | H > 118" (3m) | | | | H < 118" (3m) | | | |
|--|------------------|--------|---------|-------|------------------|--------|---------|-------|
| | WALL VERTICAL | HORIZ. | CEILING | FLOOR | WALL VERTICAL | HORIZ. | CEILING | FLOOR |
|  Mounting S1 X693 - X694 - X760 | ✗ | ✗ | ✗ | ✓ | ✓ | ✓ | ✓ | ✓ |
|  Mounting M1 to M9, G4 to G9 X689 - X690 - X691 X747 - X748 - X749 - X750 | ✗ | ✗ | ✗ | ✗ | ✗ | ✓ | ✓ | ✓ |
|  Mounting U2, U3, M2, M3, G2, G3 X688 | ✓ | ✓ | ✓ | ✓ | ✓ | ✓ | ✓ | ✓ |
|  Mounting U2 to U9 X770 - X771 - X772 | ✓ | ✓ | ✓ | ✓ | ✓ | ✓ | ✓ | ✓ |

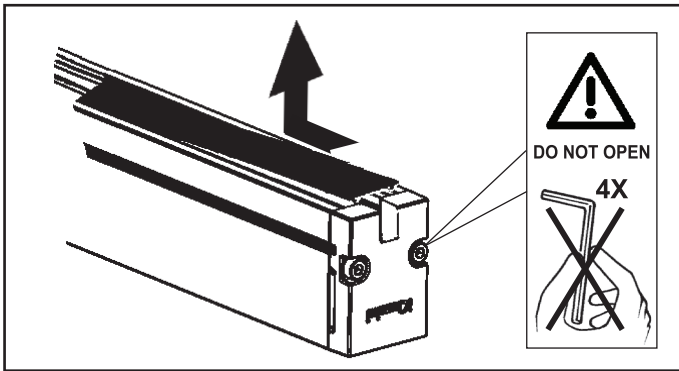

EN Handle with care and do not subject to mechanical stress.

FR Manipuler avec précaution et ne pas soumettre à des contraintes mécaniques.

ES Manejar con cuidado y no someter a tensiones mecánicas.

IT Maneggiare con cura e non sottoporre a tensioni meccaniche.

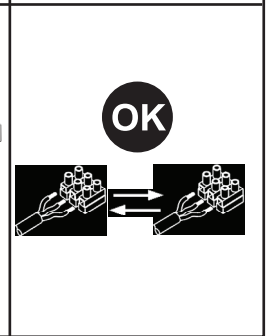
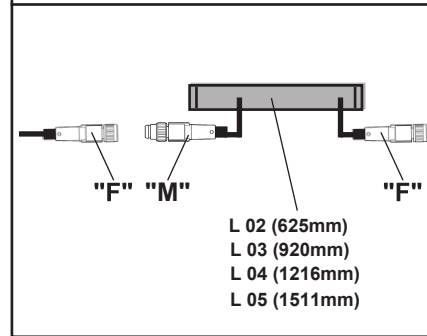
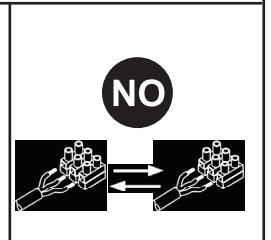
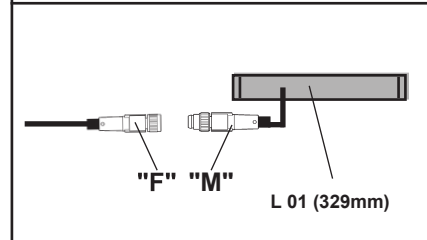
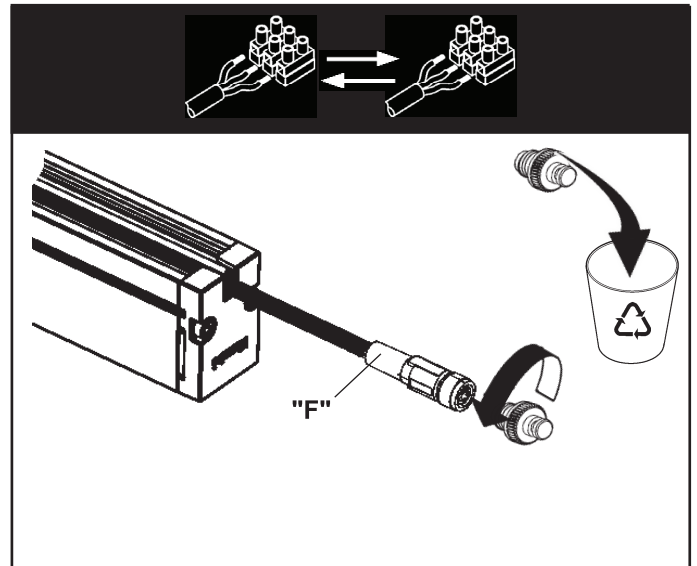
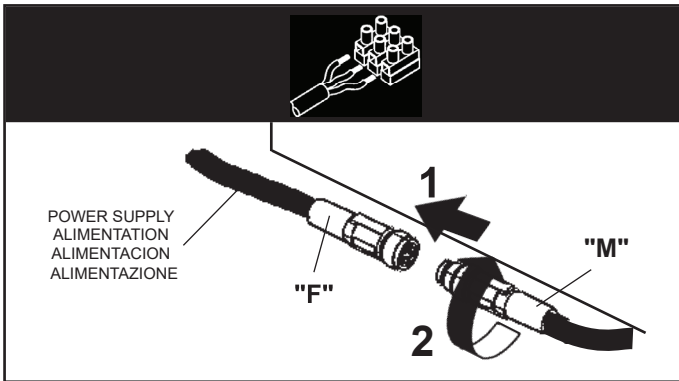

art. X688 - X689 - X690 - X691 - X747 - X748 - X749 - X750 - X770 - X771 - X772

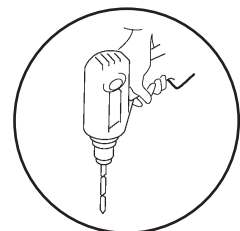
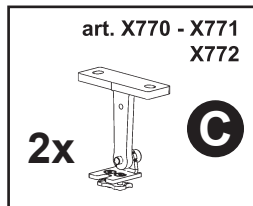
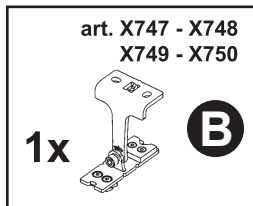
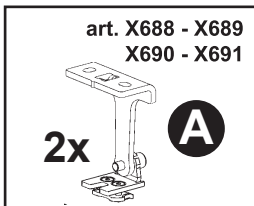

EN FOR ATTACHMENT TO WALL, USE EXPANSION SCREW; CHOOSE THE TYPE OF PLUG (NYLON, STEEL, CHEMICAL REACTION ...) ACCORDING TO THE CHARACTERISTICS OF THE SURFACE (MASONRY, CONCRETE, METAL ...) TO WHICH IT IS APPLIED.

FR POUR LA FIXATION AU MUR, UTILISEZ DES CHEVILLES A EXPANSION, LE TYPE DE CHEVILLE DOIT ÊTRE UTILISÉ (NYLON, ACIER, A REACTION CHIMIQUE ...) DOIT ÊTRE CHOISI EN FONCTION DES CARACTERISTIQUES DU MATERIAU DE SUPPORT (MAÇONNERIE, BETON, METAL ...) DU PRODUIT.

ES PARA LA FIJACION A PARED UTILIZAR TARUGOS DE EXPANSION; EL TIPO DE TARUGO QUE DEBE USARSE (NYLON, ACERO, DE REACCION QUIMICA ...) DEBERA ELEGIRSE EN FUNCION DE LAS CARACTERISTICAS DEL MATERIAL DE SOPORTE (MAMPOSTERIA, HORMIGON, METAL ...) EN EL CUAL DEBE APLICARSE EL PRODUCTO.

IT PER IL FISSAGGIO ALLA PARETE USARE TASSELLI AD ESPANSIONE; IL TIPO DI TASSELLO DA USARE (NYLON, ACCIAIO, A REAZIONE CHIMICA ...) E' DA SCEGLIERE IN FUNZIONE DELLE CARATTERISTICHE DEL MATERIALE DI SUPPORTO (MURATURA, CALCESTRUZZO, METALLO ...) SU CUI VIENE APPLICATO IL PRODOTTO.

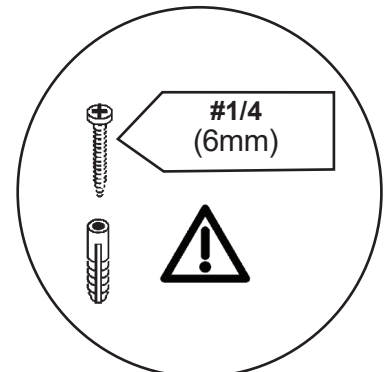

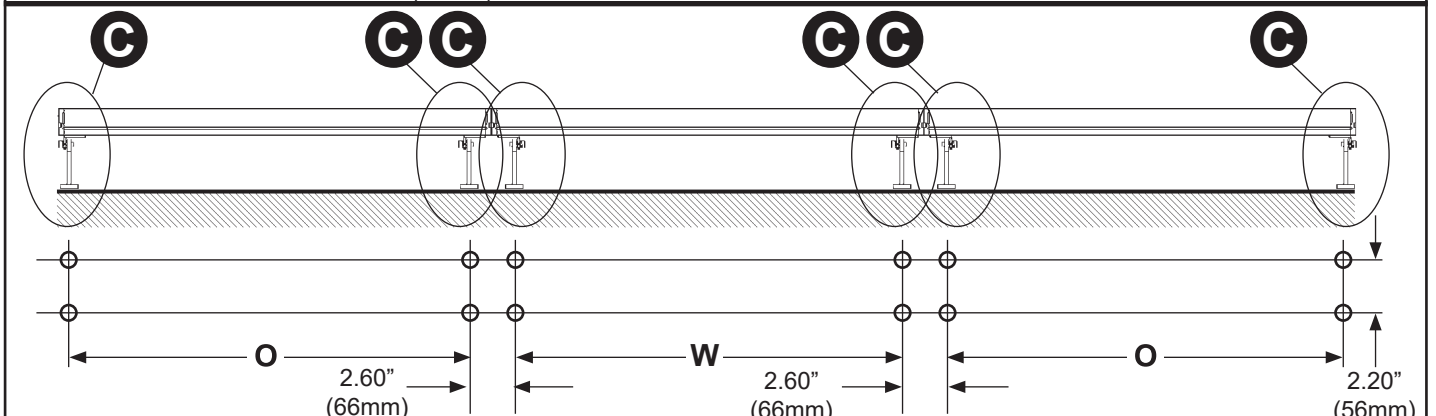
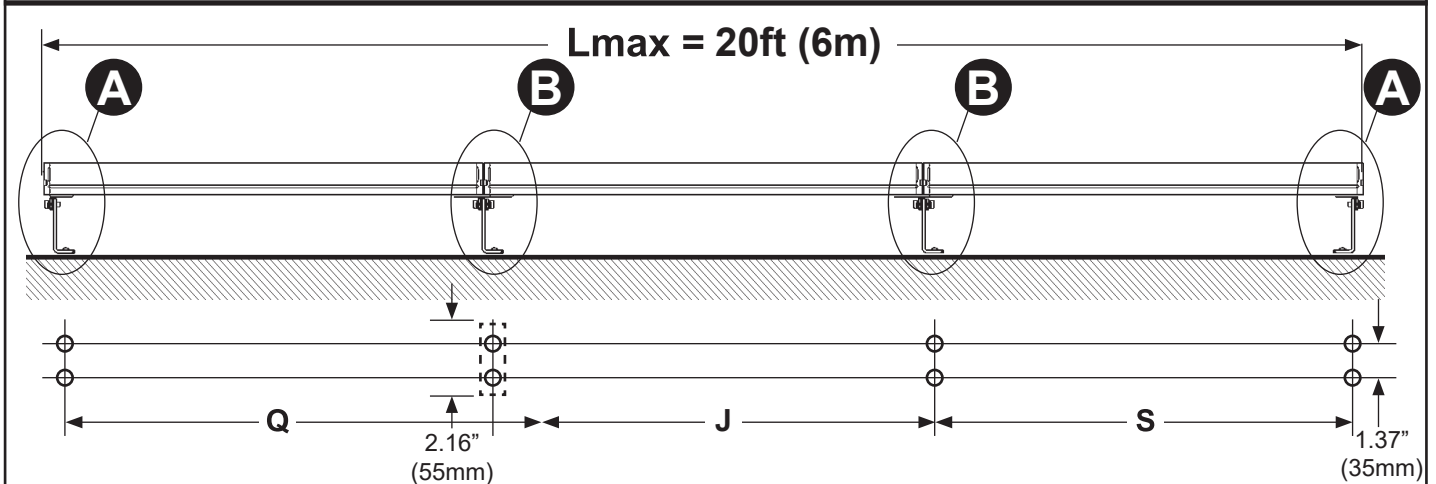
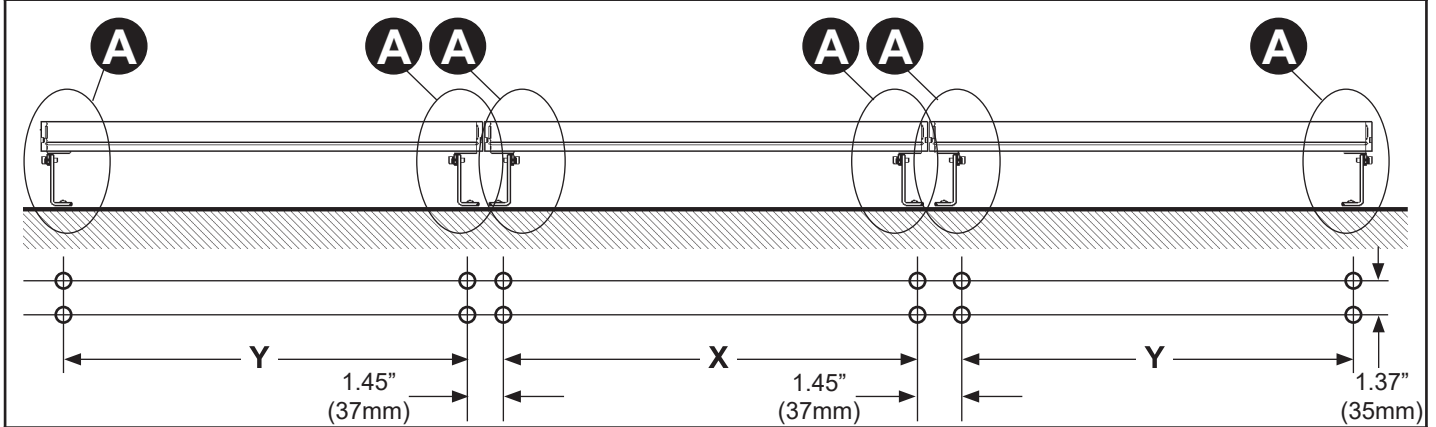
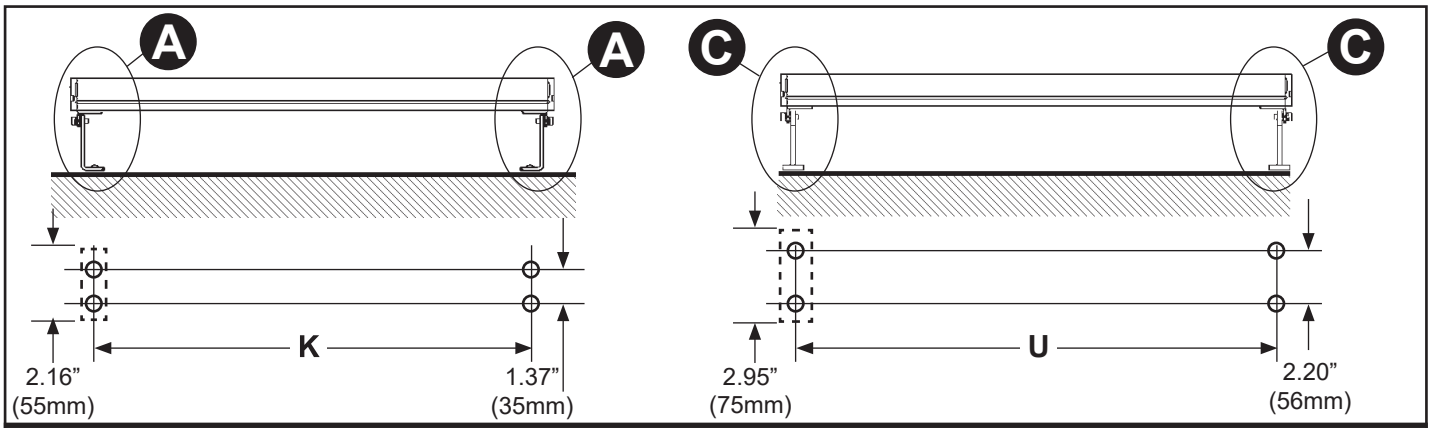

| ART. | L in (mm) | K in (mm) | X in (mm) | Y in (mm) | Q in (mm) | J in (mm) | S in (mm) | U in (mm) | O in (mm) | W in (mm) |
|---|-----------------|-----------------|-----------------|-----------------|-----------------|-----------------|-----------------|-----------------|-----------------|-----------------|
|  | 12.9 (329) | 10.6 (270) | 11.5 (294) | 11 (282) | - | - | 11.2 (285) | 11.7 (299) | 11 (282) | 10.4 (265) |
| | 24.6 (625) | 22.2 (565) | 23.2 (589) | 22.7 (577) | 24 (611) | 24.6 (626) | 22.8 (580) | 23.4 (594) | 22.7 (577) | 22 (560) |
| | 36.2 (920) | 33.9 (861) | 34.8 (885) | 34.4 (873) | 35.7 (907) | 36.3 (922) | 34.5 (876) | 35 (890) | 34.4 (873) | 33.7 (856) |
| | 47.8 (1216) | 45.5 (1156) | 46.5 (1180) | 46 (1168) | 47.3 (1202) | 48 (1217) | 46 (1171) | 46.6 (1185) | 46 (1168) | 45.3 (1151) |
| | 59.5 (1511) | 57.2 (1452) | 58 (1476) | 57.6 (1464) | 59 (1498) | 59.5 (1513) | 57.7 (1467) | 58.3 (1481) | 57.6 (1464) | 57 (1447) |

A C

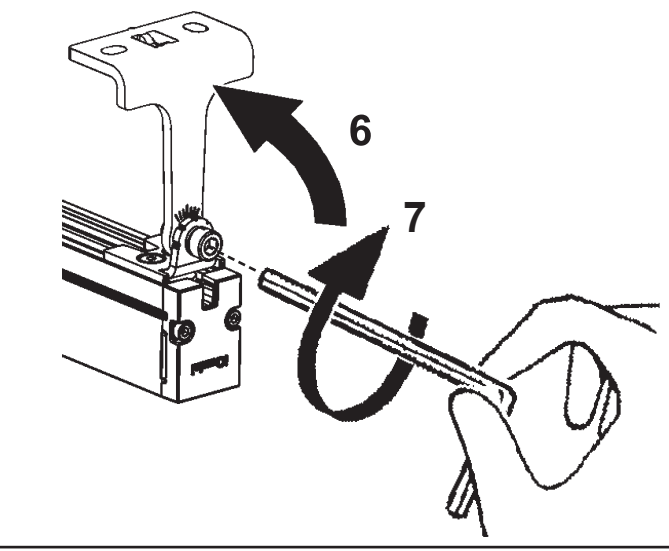
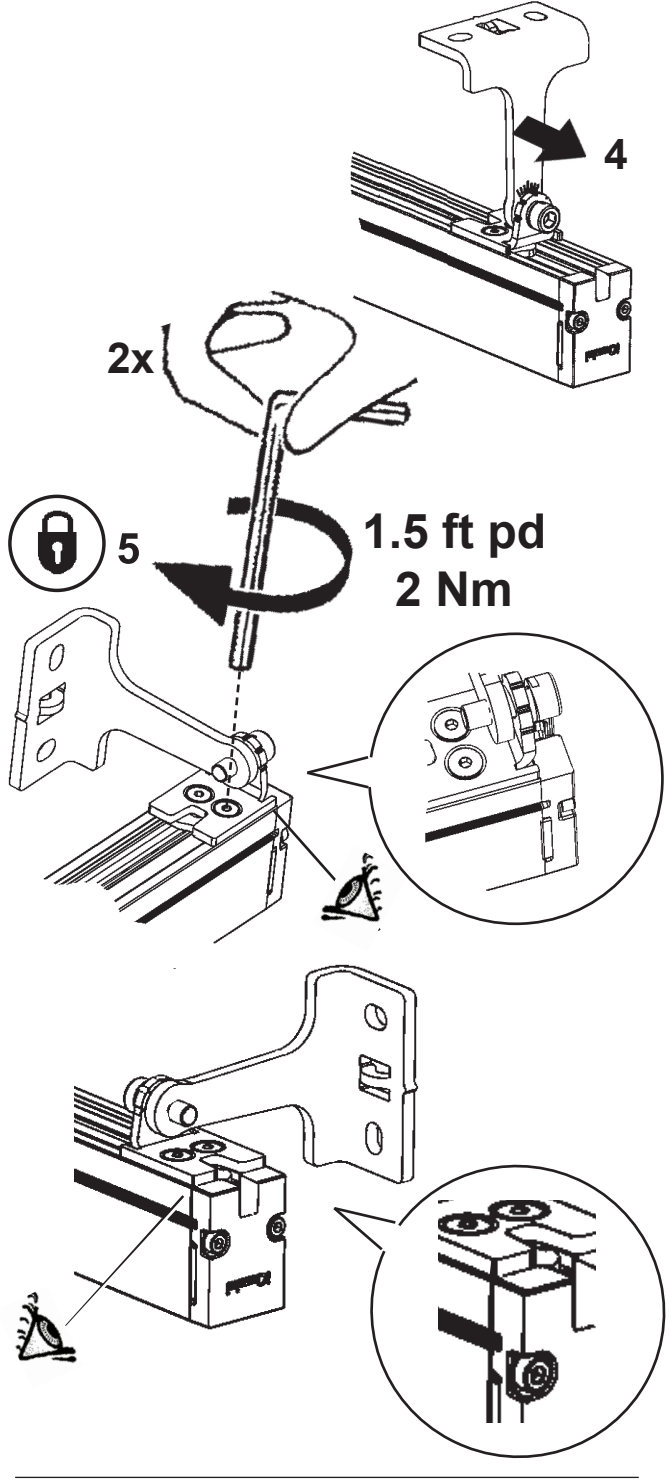
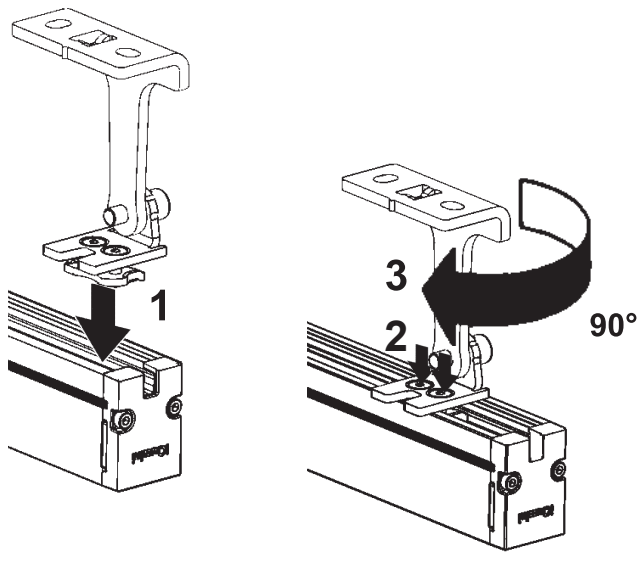
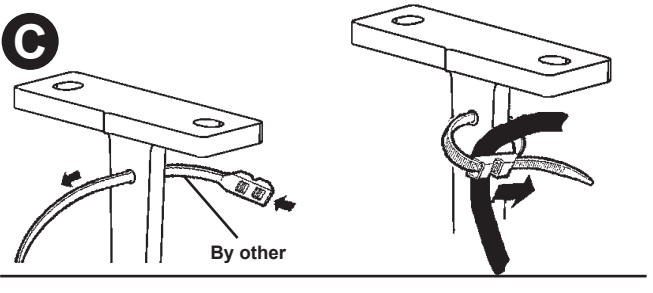
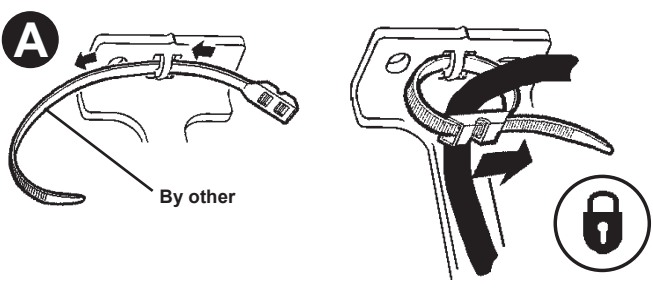
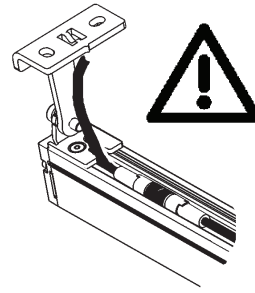
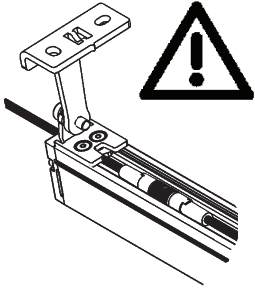

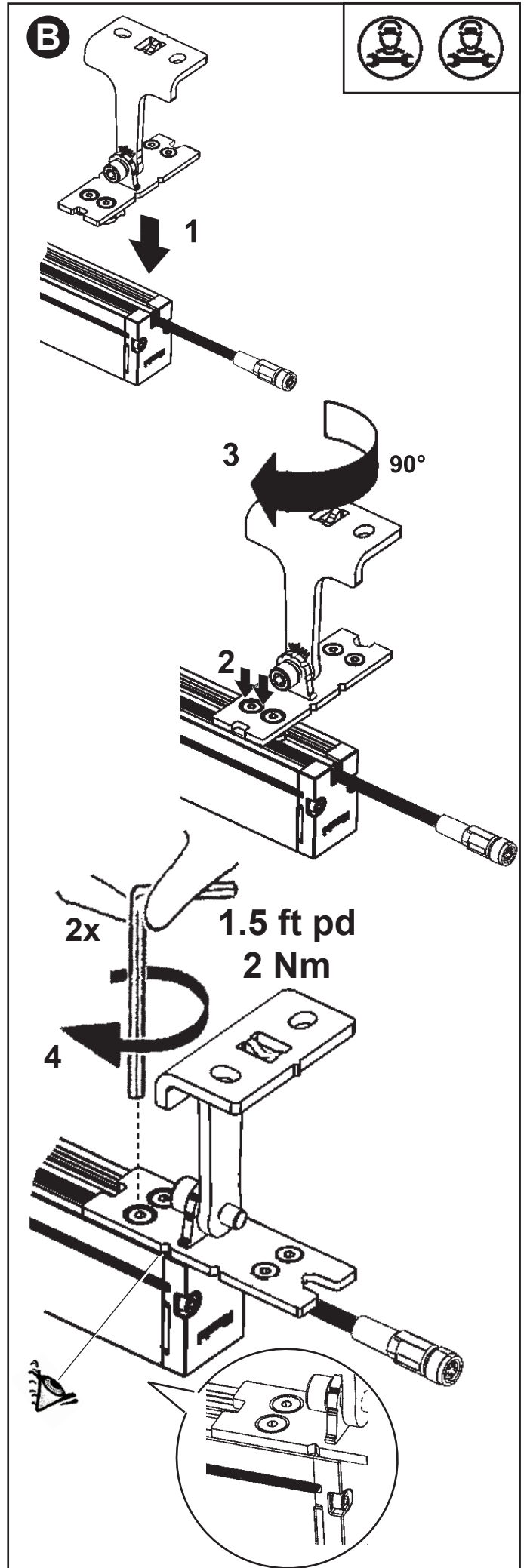
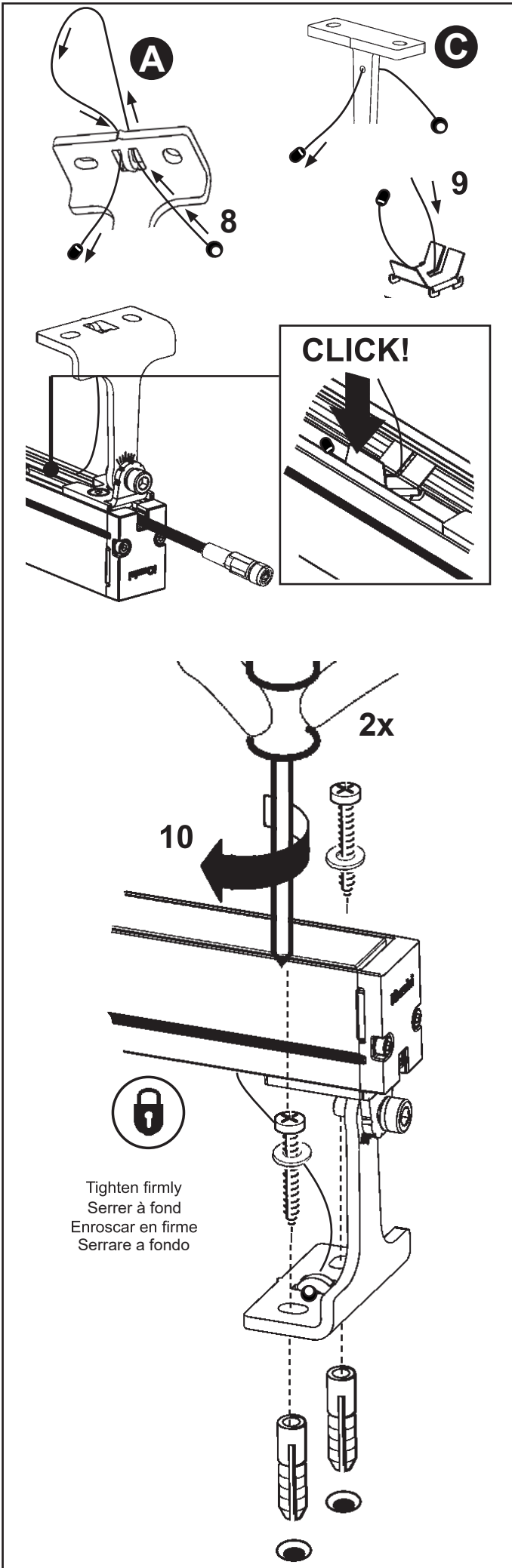

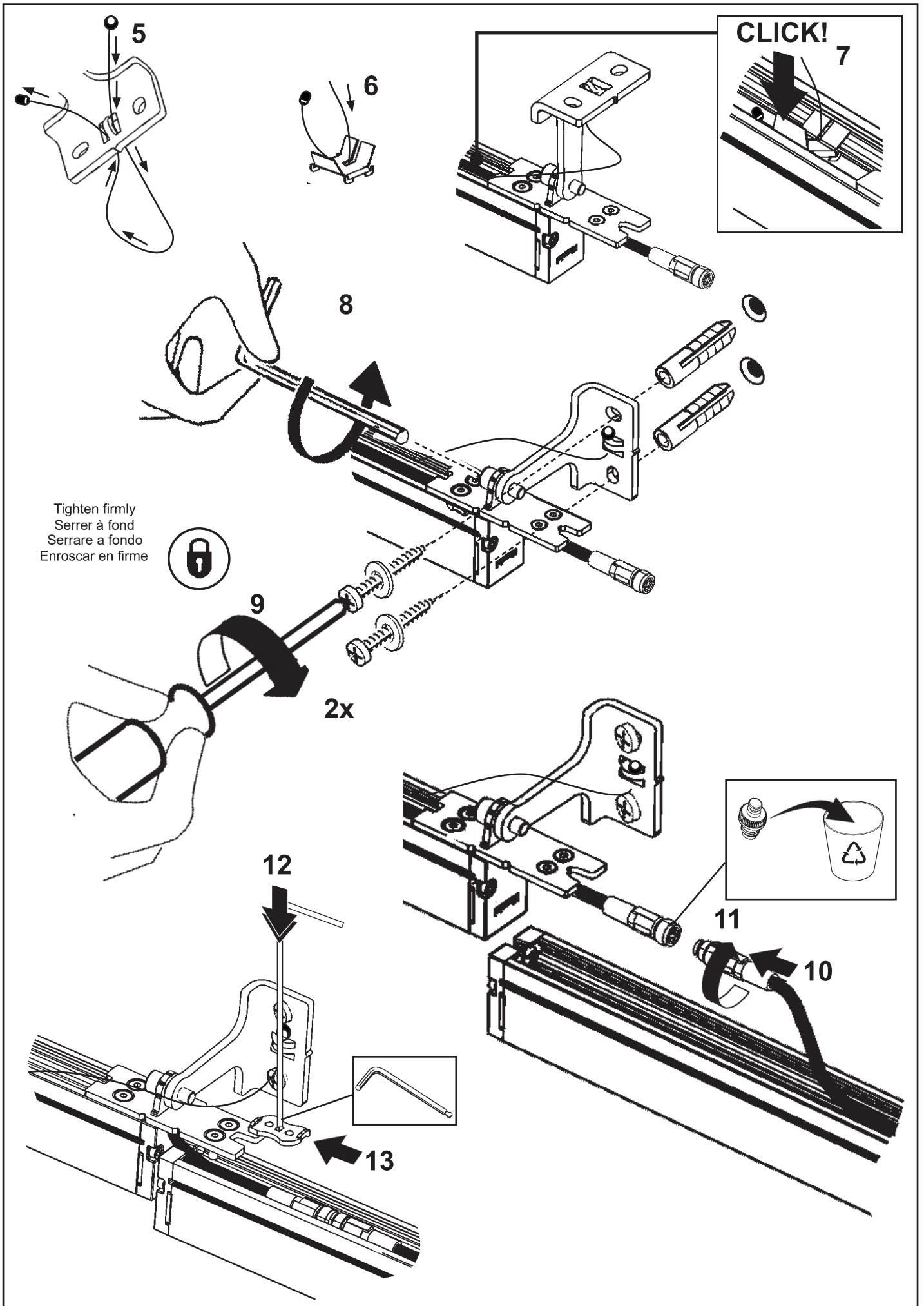

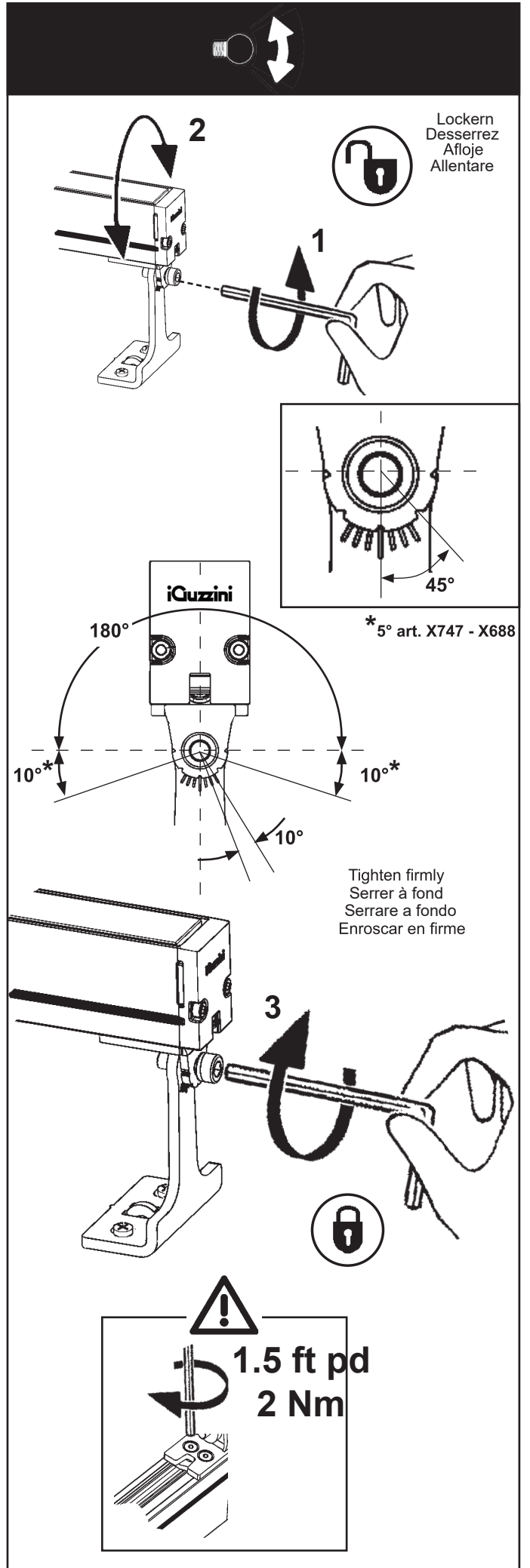
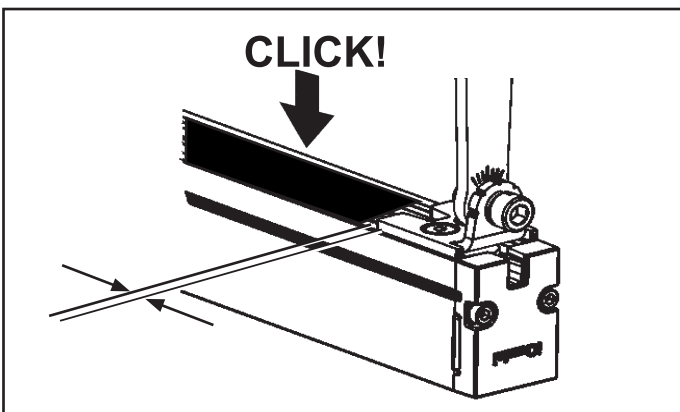
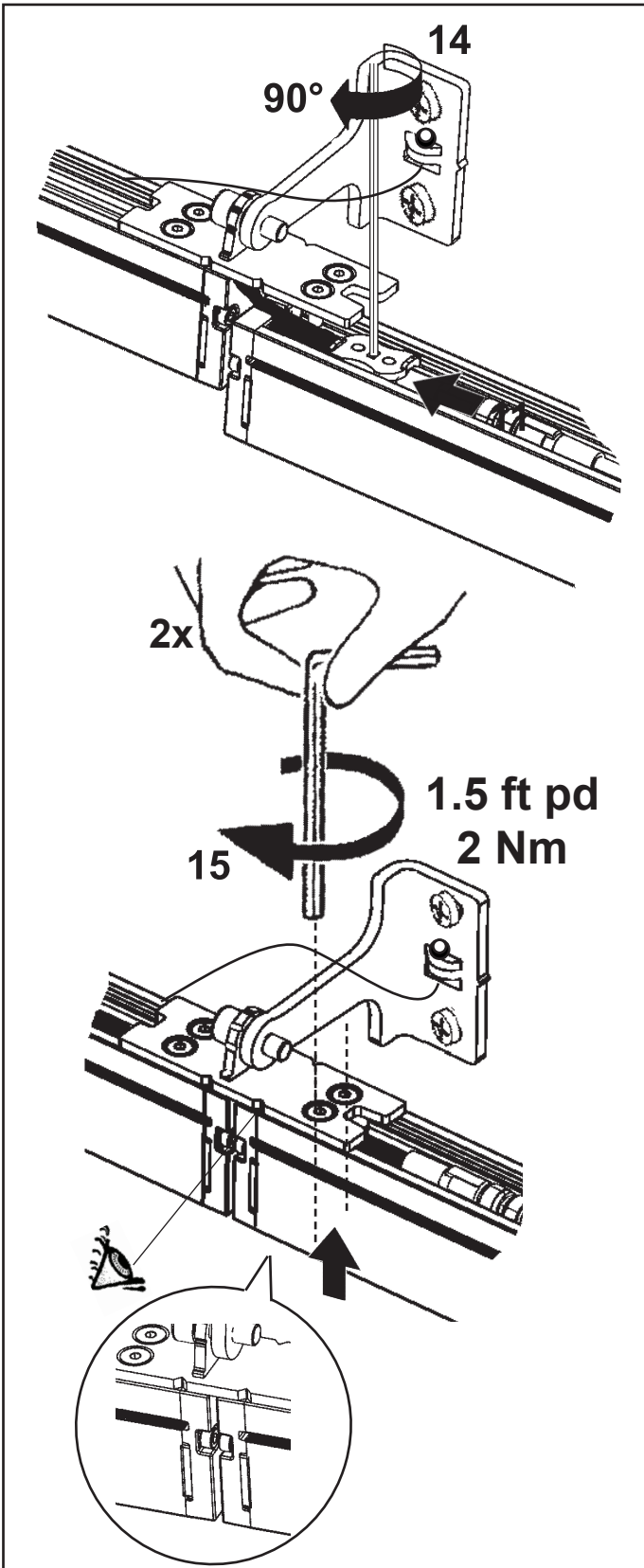

art. X693 - X694 - X760

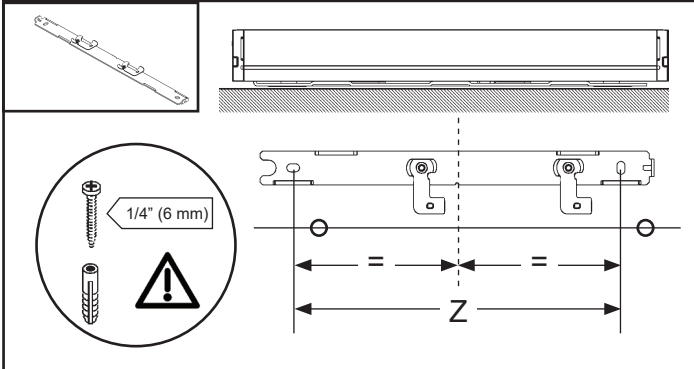

| ART. | L in (mm) | ART. X760 Z in (mm) | ART. X693 Z in (mm) | ART. X694 Z in (mm) |
|------|-----------------|---------------------------------|---------------------------------|---------------------------------|
| | 12.9 (329) | 9.6 (244) | / | / |
| | 24.6 (625) | / | 13.4 (340) | / |
| | 36.2 (920) | / | 13.4 (340) | / |
| | 47.8 (1216) | / | / | 22.4 (570) |
| | 59.5 (1511) | / | / | 22.4 (570) |

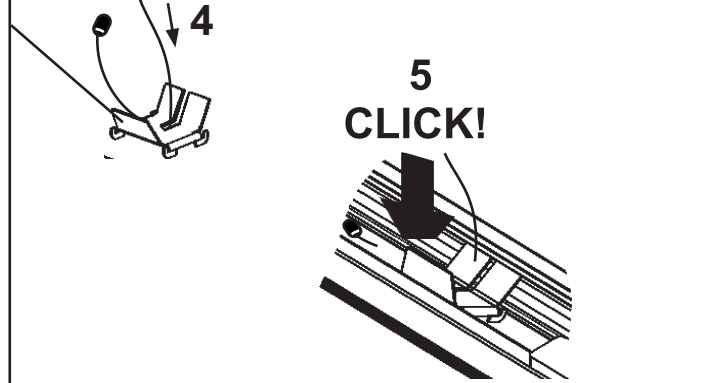
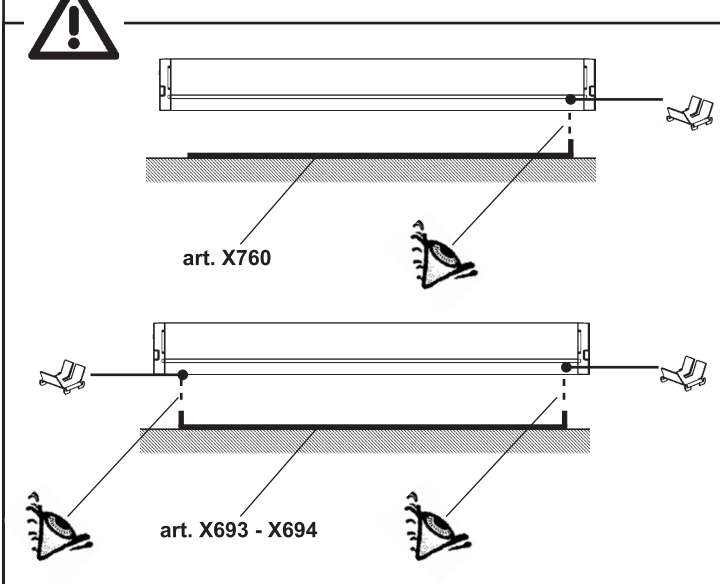
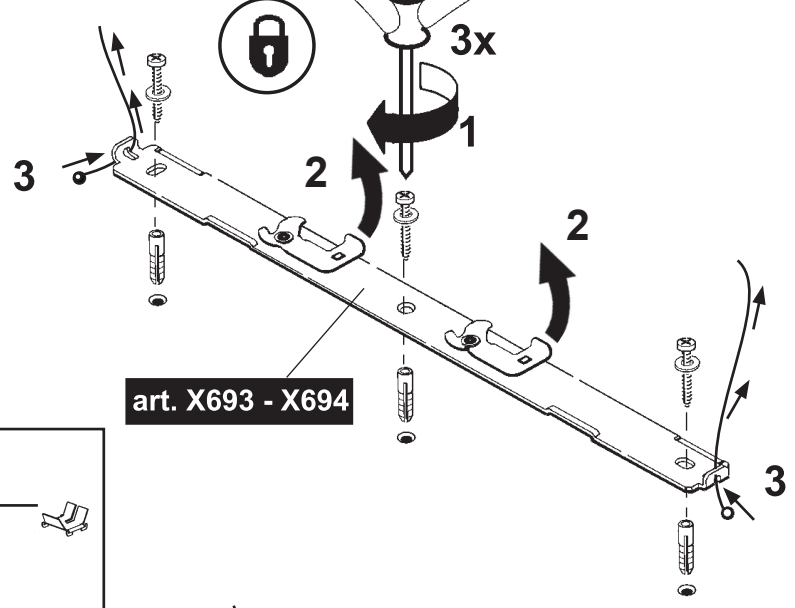
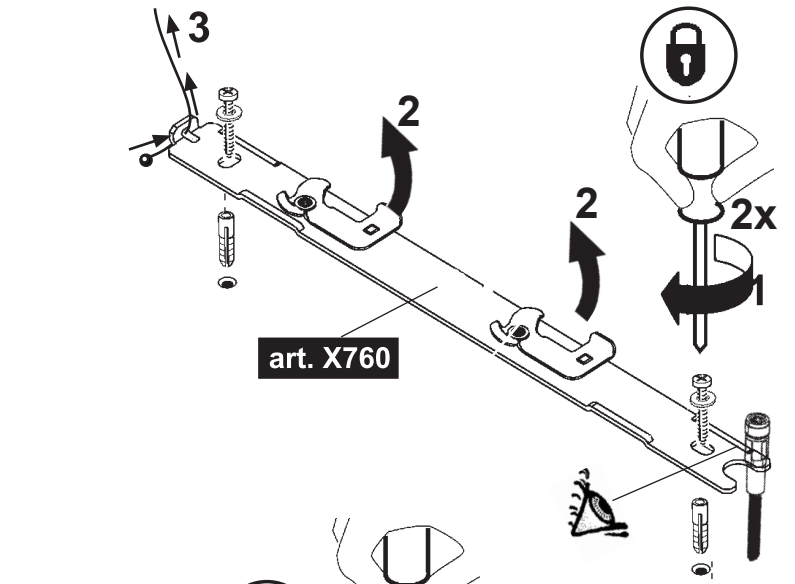
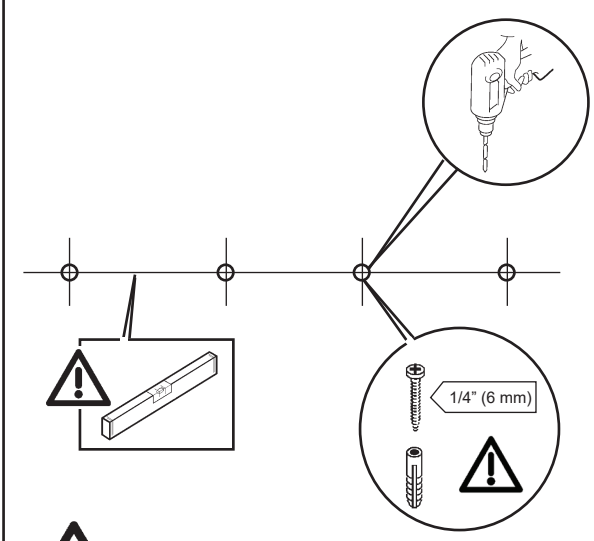
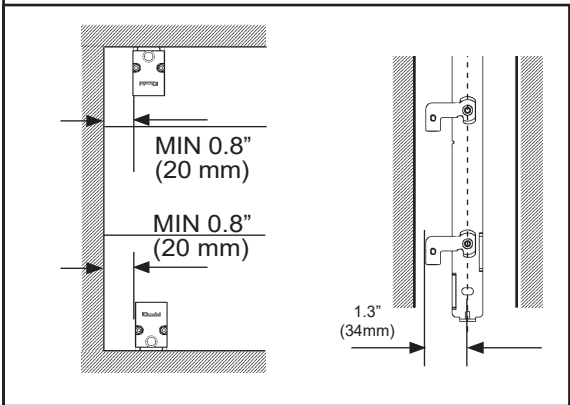

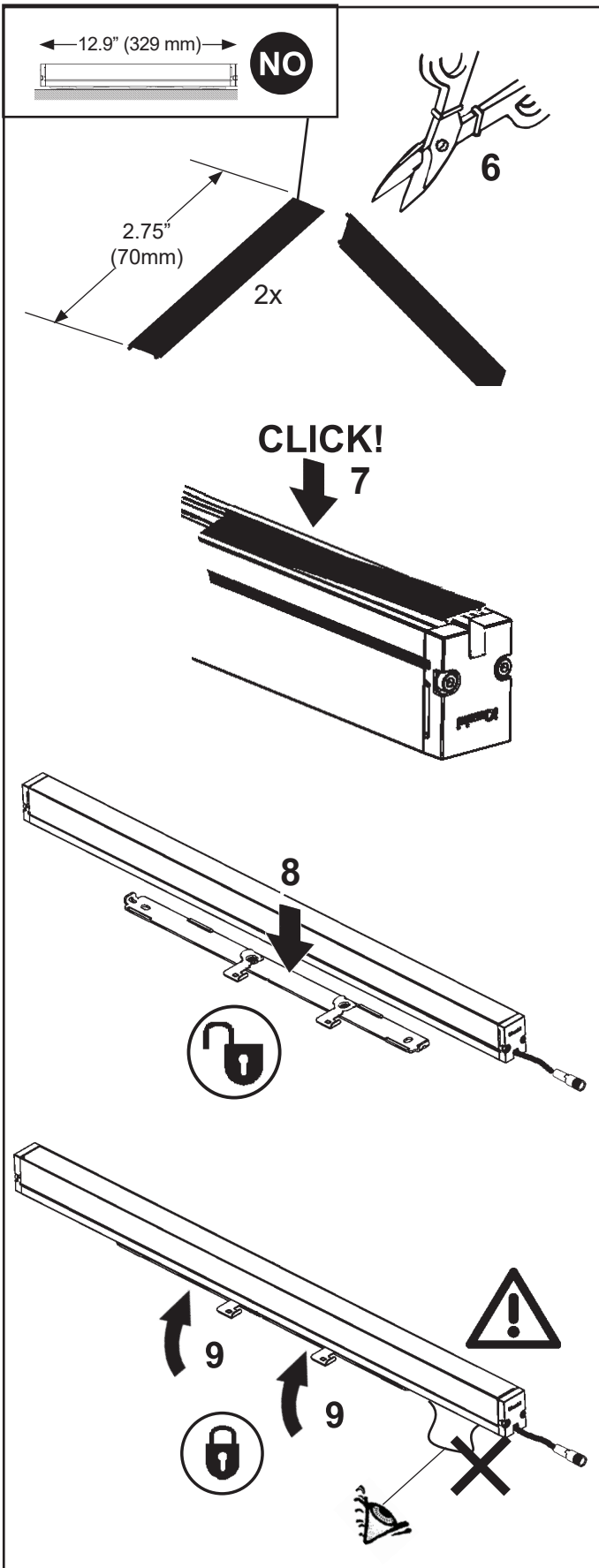

EN Before powering the system, make sure polarities were properly connected. Incorrect connection may cause the product to malfunction.

FR Avant de mettre l'installation sous tension, assurez-vous que la polarité de connexion est respectée. Une erreur de connexion peut entraîner le mauvais fonctionnement du produit.

ES Antes de alimentar la instalación compruebe que la conexión de las polaridades sea correcta. Una conexión incorrecta puede ocasionar el malfuncionamiento de los productos.

IT Prima di alimentare l'impianto assicurarsi del corretto collegamento delle polarità. Un errato collegamento può comportare il malfuncionamento dei prodotti.

EN Wire the power supply to the electrical mains only after the connection to the products has been carried out









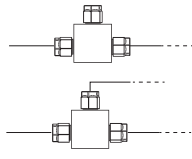

FR N'effectuer le câblage au ballast électrique qu'après avoir effectué le raccordement aux produits

ES Cablear el alimentador a la red eléctrica sólo después de conectar los productos

IT Cablare alla rete elettrica l'alimentatore solo dopo aver effettuato il collegamento ai prodotti

ACCESSORY

ELECTRICAL JUNCTION ELEMENTS FONCTION - CABLES

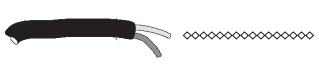
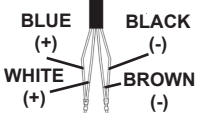
| | |
|--|--|
| 4543 |  <p style="text-align: right;">Wet location connection box For cable Ø3/16" to 7/16" (4mm to 11mm)</p> |
|   | |
| X720 |  <p style="text-align: right;">L=23.6" (600mm) Ø0.15" (3,9mm) 20AWG (0,5 mm²)</p> |
| X721 |  <p style="text-align: right;">L=59" (1500mm) Ø0.15" (3,9mm) 20AWG (0,5 mm²)</p> |
| X773 |  <p style="text-align: right;">L=13.88" (350mm) Ø0.15" (3,9mm) 20AWG (0,5 mm²)</p> |
| X169 |  <p style="text-align: right;">L=59" (1500mm) Ø0.15" (3,9mm) 20AWG (0,5 mm²)</p> |
| X170 |  <p style="text-align: right;">L=118" (3000mm) Ø0.15" (3,9mm) 20AWG (0,5 mm²)</p> |
| X171 |  <p style="text-align: right;">L=196.8" (5000mm) Ø0.15" (3,9mm) 20AWG (0,5 mm²)</p> |
| X173 |  <p style="text-align: right;">L=59" (1500mm) Ø0.15" (3,9mm) 20AWG (0,5 mm²)</p> |
| USER CABLES |   |
| X773 - X169 X170 - X171 X173 |  |

EN When planning the lighting and electrical system, determine the maximum permitted current, taking into account the following factors:

- the nominal current permitted by terminal blocks;
- safety coefficient to allow for excess voltage and contemporaneity;
- the nominal current absorbed by single art.

It is recommended that the wires inside the cables are made to operate at the maximum values.

FR Lors de l'étude de projet de l'installation d'éclairage et de l'installation électrique, déterminer les courants maximaux admissibles en tenant compte des facteurs suivants :

- courant maximal admis par les borniers;
- coefficient de sécurité tenant compte des surtensions et de la simultanéité;
- courant nominal absorbé par les différents art.

Il est conseillé de ne pas faire fonctionner les câbles aux valeurs maximales.

ES Durante la proyectación de la instalación luminotécnica y eléctrica, determinar las corrientes máximas permitidas, en consideración de los factores siguientes:

- corriente nominal permitida de las borneras;
- coeficiente de seguridad para considerar sobretensiones y contemporaneidades;
- corriente nominal absorbida por los art. individuales.

Se aconseja evitar que los conductores de cables trabajen con valores máximos.

IT Nella progettazione dell'impianto illuminotecnico ed elettrico, determinare le correnti massime ammissibili, considerando i seguenti fattori:

- corrente nominale ammessa dalle morsettiere;
- coefficiente di sicurezza per tenere conto delle sovratensioni e contemporaneità;
- corrente nominale assorbita dai singoli art.

E' buona norma evitare di far lavorare i conduttori dei cavi ai massimi valori.

EXAMPLE ELECTRIC CONNECTION

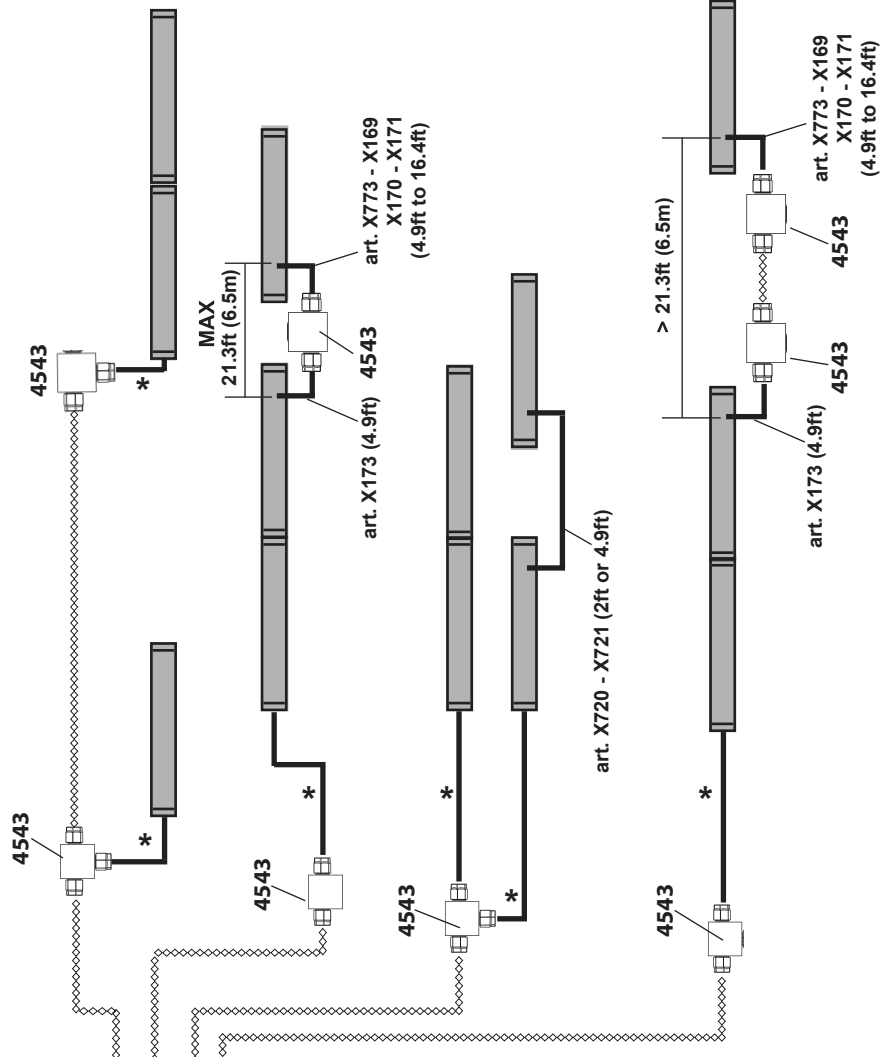

20AWG
 * art. X169 (4.9ft)
 X170 (9.8ft)
 X773 (13.8ft)
 X171 (16.4ft)

AWG by other.
 Depend on the length of the circuit.
 Use calculator formula on page 13.

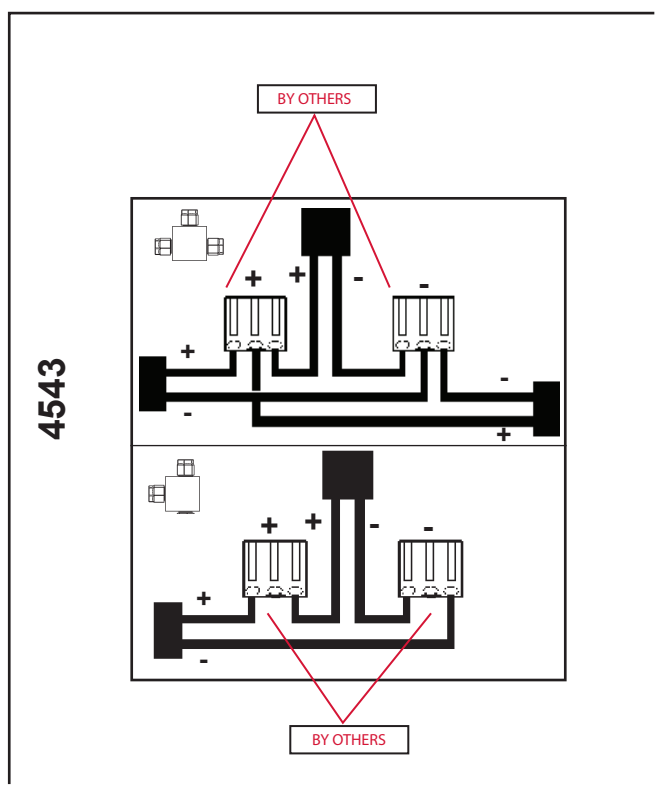

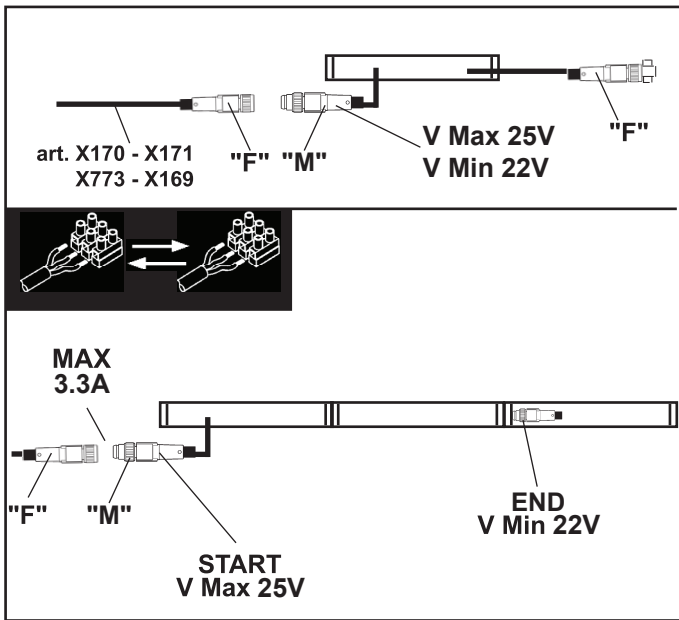

Cable length L (m)

$$L = \frac{\Delta V \times S}{2 \times I \times 0,0174}$$

EN To calculate the max length of the cable:
 FR Pour calculer la longueur maximale du câble :
 ES Para calcular la longitud del cable Máx:
 IT Per calcolare la lunghezza del cavo Max:

Lc = L1+L2 Max = 328ft (100m)

- EN** iGuzzini tests and guarantees the correct operation of its products/power supply system up to a maximum distance of 328ft (100m)
 For greater distances, it is the customer's responsibility to check safety conditions and operation.
- FR** iGuzzini teste et garantit le fonctionnement du système d'alimentation/des produits jusqu'à une distance de 328ft (100 m)
 Au-delà de cette distance, il appartient au client de s'assurer des conditions de sécurité et de fonctionnement.
- ES** iGuzzini prueba y garantiza el funcionamiento del sistema alimentador/productos hasta una distancia máxima de 328ft (100m)
 Para longitudes superiores es responsabilidad del cliente comprobar las condiciones de seguridad y de funcionamiento.
- IT** La iGuzzini testa e garantisce la funzionalità del sistema alimentatore/prodotti fino a una distanza massima di 328ft (100mt)
 Per lunghezze superiori è responsabilità del cliente verificare le condizioni di sicurezza e di funzionamento.

(1) **Section cable converting chart**

| AWG | mm ² |
|-----|-----------------|
| 30 | 0.05 |
| 28 | 0.08 |
| 26 | 0.14 |
| 24 | 0.25 |
| 22 | 0.34 |
| 21 | 0.38 |
| 20 | 0.50 |
| 18 | 0.75 |
| 17 | 1.0 |
| 16 | 1.5 |
| 14 | 2.5 |
| 12 | 4.0 |
| 10 | 6.0 |

(2) **1 meter = 3.28 foot**

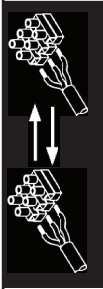

| PRODUCT L tot ft (m) | corrente assorbita absorbed current courant absorbé corriente absorbida A | V start min V |
|----------------------------|---|------------------|
| 10 (3) | 1.7 | 22.5 |
| 15 (4.5) | 2.5 | 23 |
| 20 (6) MAX | 3.3 | 24 |

0.55A/m 0.17A/ft

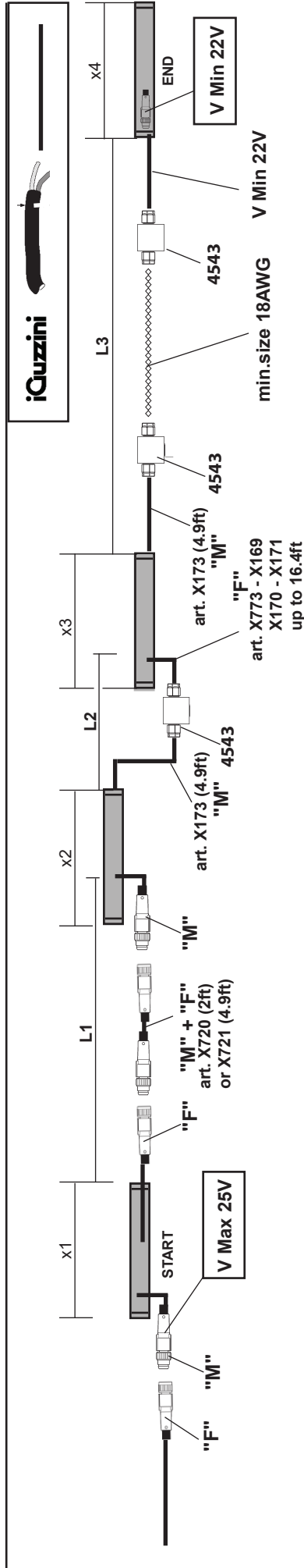
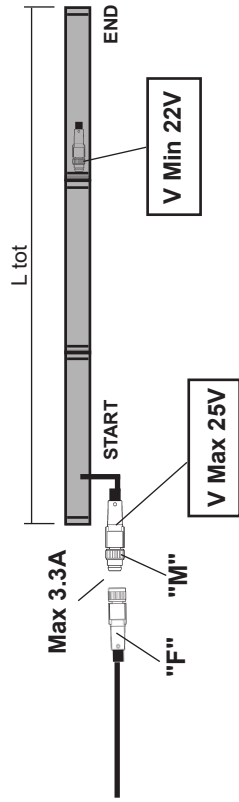

TIP: You can adjust the driver's Vo (22 to 27Vdc) with a small flat or philips screwdriver. See driver box instruction for more details.

| PRODUCT L tot ft (m) | Total cable length - Longueur totale du câble Longitud total cable - Lunghezza totale cavo | |
|----------------------------|---|------------|
| | Vstart 24V | Vstart 25V |
| x1 + x2 + x3 + x4+ ... xn | L1 + L2 + L3+ ... Ln | |
| 10 (3) | 78.7 (24) | 124.6 (38) |
| 15 (4.5) | 26.2 (8) | 49.2 (15) |
| 20 (6) MAX | 1.6 (0.5) | 16.4 (5) |

EN **iGuzzini tests and guarantees the correct operation of its products/power supply system up to a maximum distance of 328ft (100 m). For greater distances, it is the customer's responsibility to check safety conditions and operation.

FR **iGuzzini teste et garantit le fonctionnement du système d'alimentation/des produits jusqu'à une distance de 328ft (100m). Au-delà de cette distance, il appartient au client de s'assurer des conditions de sécurité et de fonctionnement.

ES **iGuzzini prueba y garantiza el funcionamiento del sistema alimentador/productos hasta una distancia máxima de 328ft (100m). Para longitudes superiores es responsabilidad del cliente comprobar las condiciones de seguridad y de funcionamiento.

IT **La iGuzzini testa e garantisce la funzionalità del sistema alimentatore/prodotti fino a una distanza massima di 328ft (100mt). Per lunghezze superiori è responsabilità del cliente verificare le condizioni di sicurezza e di funzionamento.

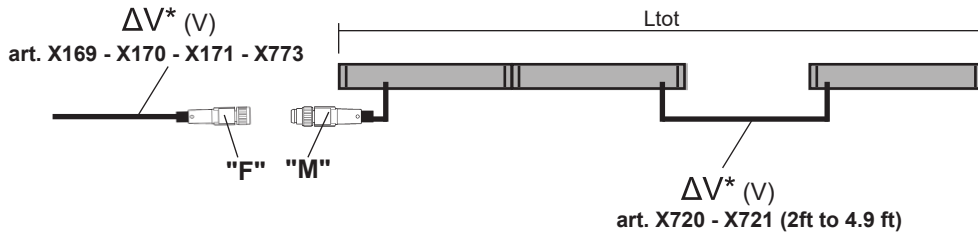

Voltage drop ΔV (V)

iGuzzini

| L tot ft (m) | Voltage drop ΔV* (V) | | | | | | |
|-----------------|-------------------------|--------------|--------------|---------------|--------------|------------|--------------|
| | X773 (13.8ft) | X169 (4.9ft) | X170 (9.8ft) | X171 (16.4ft) | X173 (4.9ft) | X720 (2ft) | X721 (4.9ft) |
| 10 (3) | 0,05 | 0,23 | 0,45 | 0,75 | 0,23 | 0,09 | 0,22 |
| 15 (4.5) | 0,08 | 0,35 | 0,68 | 1.12 | 0,35 | 0,13 | 0,33 |
| 20 (6) MAX | 0,10 | 0,46 | 0,91 | 1,50 | 0,46 | 0,18 | 0,45 |

$$\Delta V = \frac{0,0174 \times 2 \times L \times I}{S}$$

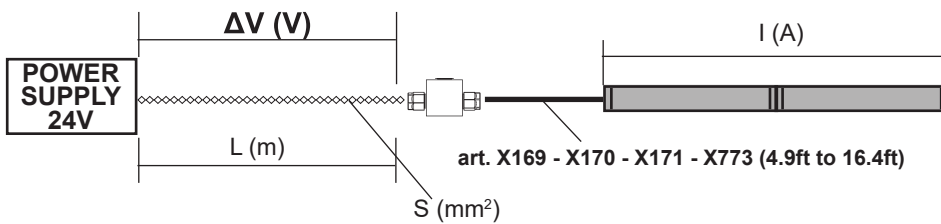

Voltage drop ΔV (V)

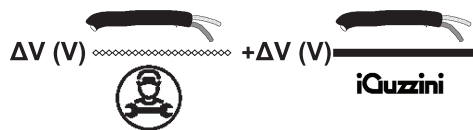

Voltage drop TOT ΔV (V)

$$P = \Delta V \times I$$

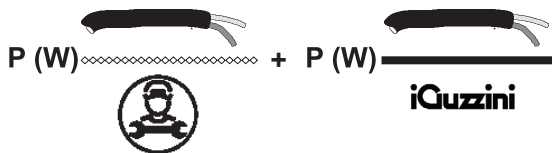

Power dissipation of cables P(W)

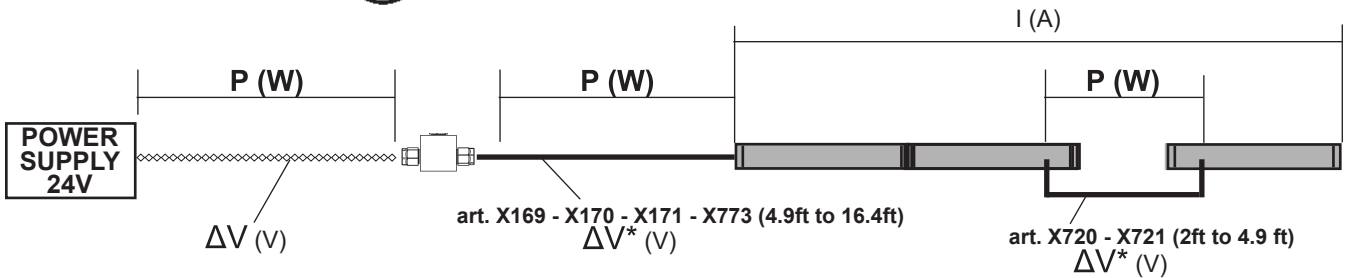

| L tot PRODUCT ft (m) | P PRODUCT (W) |
|----------------------------|---------------|
| 10 (3) | 39 |
| 15 (4.5) | 59 |
| 20 (6) MAX | 78 |

3.9W/ft (13 W/m)

Power PRODUCT P(W)

$$P_{TOT} (W) = P_{PRODUCT} + P_{DISSIPATION OF CABLES}$$

POWER TOT P (W)



- EN** The connector cannot be continuously submerged in water.
FR Le connecteur ne peut pas rester continuellement sous l'eau.
ES El conector no puede estar continuamente sumergido en agua.
IT Il connettore non può trovarsi in maniera continuativa immerso in acqua.
- EN** The assembly must be located in such a way that if any water enters, it will drain out and not stagnate.
FR L'espace de logement doit être drainant et ne pas favoriser les stagnations d'eau.
ES Es necesario que el alojamiento en el que se ubica conste de drenaje para evitar que quede agua estancada.
IT Necessario che il vano dove viene alloggiato sia drenante e non favorisca il ristagno di acqua.
- EN** If there is any risk of long-term submersion, suitable connections (such as muffles) should be used.
FR En présence d'un risque d'immersion prolongée, il est conseillé d'utiliser des branchements adéquats (ex. manchons).
ES En caso de existir riesgo de inmersión durante largo tiempo deben utilizarse conexiones adecuadas (p. ej.: mufas).
IT Se c'è il rischio di immersione per lungo tempo è bene adottare connessioni adeguate (es. muffole).

- EN** If the external flexible cable or cord of this luminaire is damaged, it shall be exclusively replaced by the manufacturer or his service agent or a similar qualified person in order to avoid a hazard
FR Si le cordon ou le câble flexible extérieur de l'appareil est endommagé faites -le remplacer exclusivement par le fabricant, l'agent service clients ou par une personne qualifiée, de manière à éviter tout risque.
ES En caso de estar dañado el cordón o el cable flexible externo del aparato, hágalo sustituir exclusivamente por el fabricante, por el encargado del servicio clientes o por una persona calificada para evitar cualquier tipo de riesgo.
IT Nel caso in cui il cordone o il cavo flessibile esterno dell'apparecchio risulti danneggiato, sostituire esclusivamente dal produttore, dall'addetto al servizio clienti o da una persona qualificata in modo da evitare qualsiasi rischio.

- EN** N.B.: For information on LED replacement please contact iGuzzini.
FR N.B.: Pour procéder au remplacement de la LED, adressez-vous à la société iGuzzini.
ES NOTA: Para sustituir el LED llame a la empresa iGuzzini.
IT N.B.: Per la sostituzione del LED contattare l'azienda iGuzzini.



- EN** Should the glass break, the product cannot be used and you should contact the manufacturer for its replacement.
FR En cas d'endommagement de l'écran de protection le produit ne peut pas être utilisé, contactez le fabricant pour le remplacement.
ES No utilizar el producto en caso de ruptura del vidrio y contactar el fabricante para la sustitución.
IT In caso di rottura del vetro il prodotto non può essere utilizzato, contattare il costruttore per la sua sostituzione.

- EN** DO NOT SUBMIT THE PRODUCT TO TWISTING
FR NE PAS SOUMETTRE LE PRODUIT À TORSION
ES NO FORZAR LA TORSIÓN DEL PRODUCTO
IT NON SOLLECITARE IL PRODOTTO A TORSIONE

OPTICAL ACCESSORIES

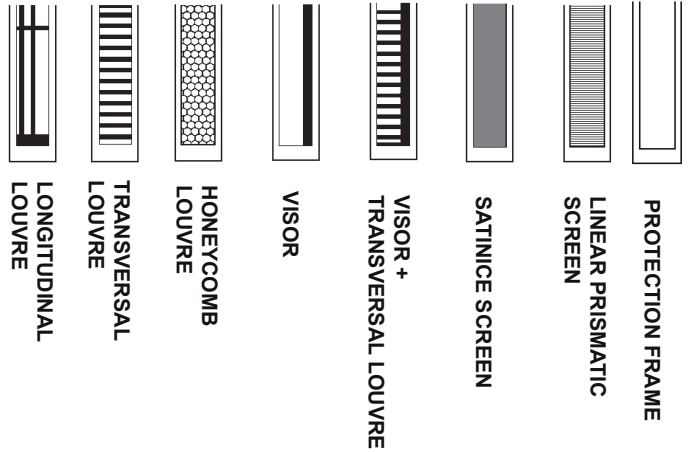

- 
- EN** Any accessories or mechanical supports must be assembled before installing the product.
FR Les accessoires et les supports mécaniques doivent être assemblés avant d'installer le produit.
ES Ensamblar los accesorios y los soportes mecánicos antes de instalar el producto.
IT Gli accessori e i supporti meccanici devono essere assemblati prima di installare il prodotto.

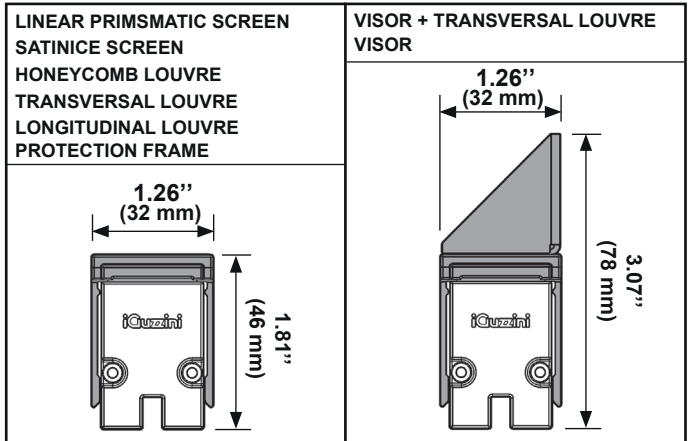



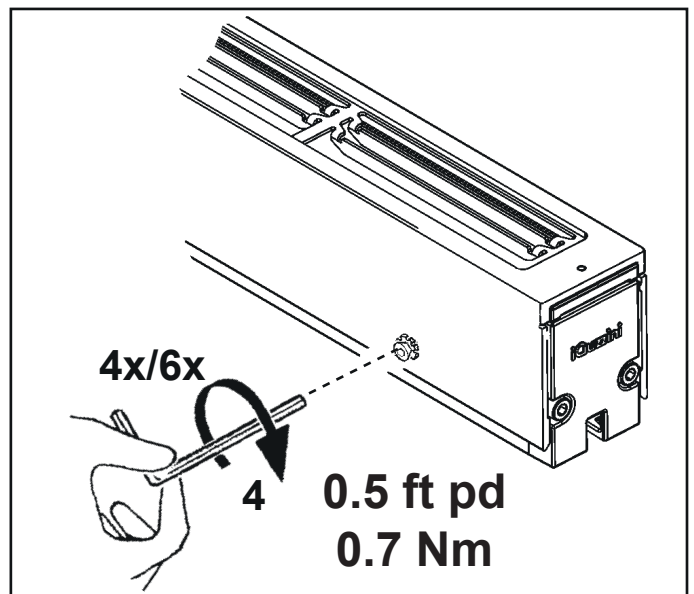
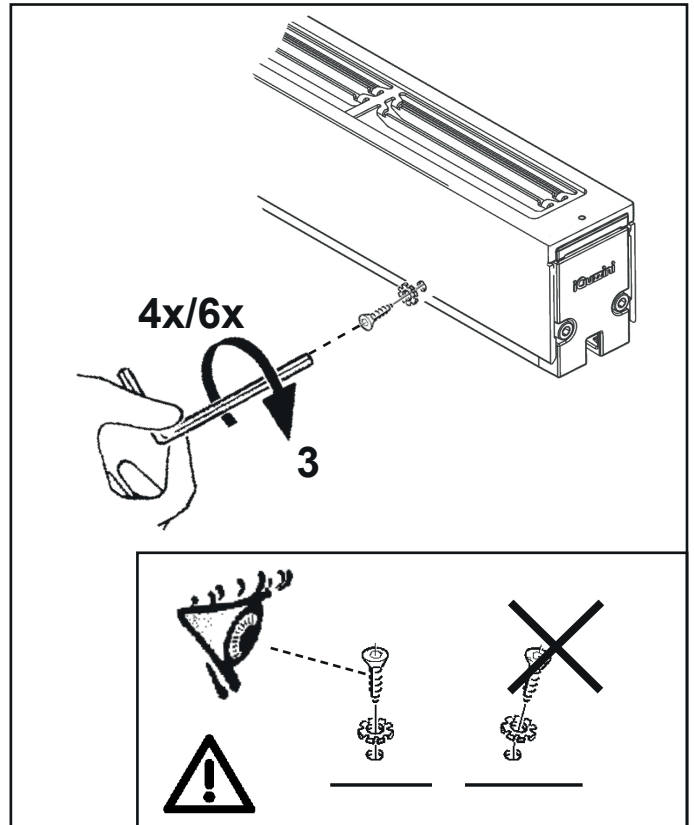
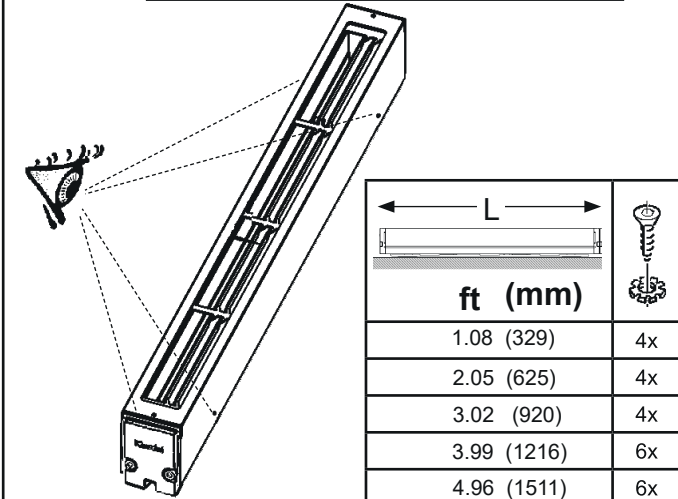
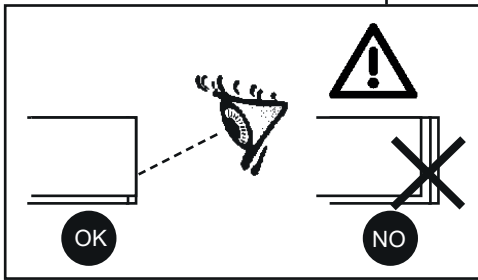
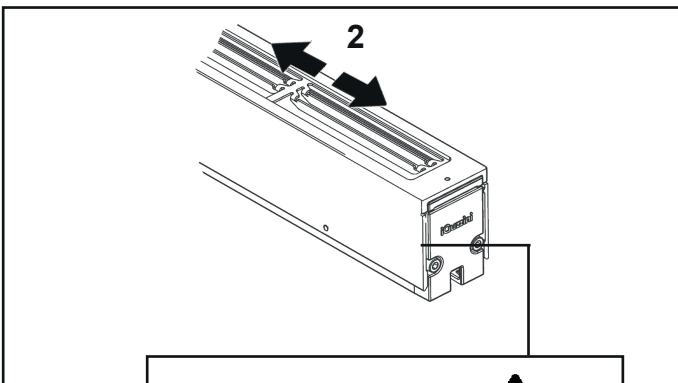
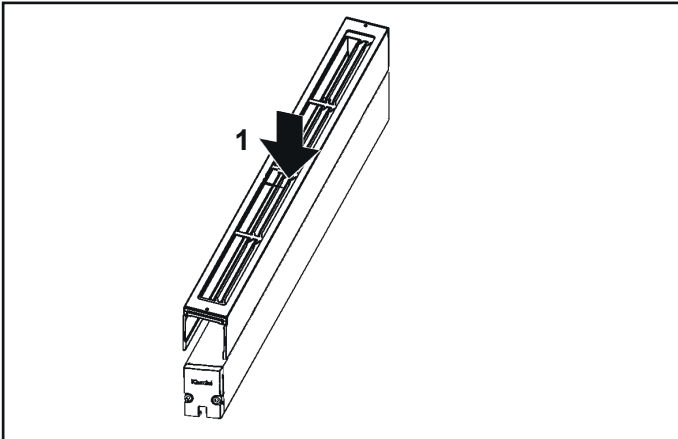
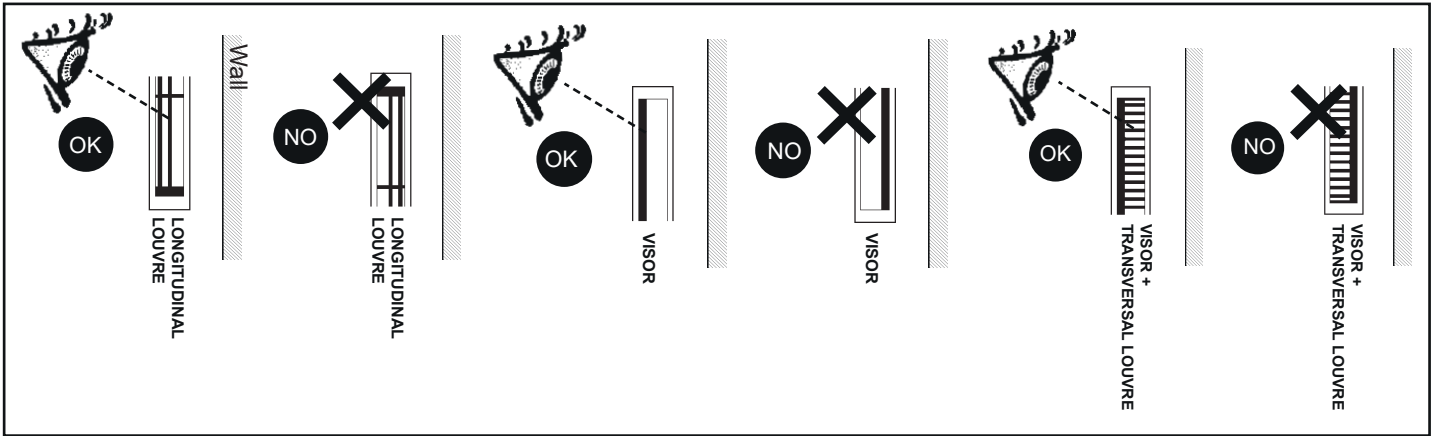



- EN** We do not recommend using the lighting product, with accessory, facing upwards, otherwise the product must be cleaned regularly.
FR Il est déconseillé d'utiliser le produit avec un accessoire quand la lumière est dirigée vers le haut, sinon un nettoyage programmé du produit doit être prévu.
ES Se desaconseja utilizar la luminaria con el accesorio en posición de emisión de luz hacia arriba. En caso de hacerlo, se deberá programar un plan de limpieza del producto.
IT Si sconsiglia l'utilizzo del prodotto con accessorio nella posizione con luce UP, altrimenti è necessario prevedere una pulizia programmata del prodotto.

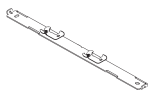

OPTICAL ACCESSORIES

| LED Colour | Optic | Art. | A4 | A3 | A5 | A2 | A6 | A7 | A1 |
|---------------------|--------------|--|---------------------|--------------------|------------------|-------|----------------------------|-------------------------|--------------|
| | | | LONGITUDINAL LOUVRE | TRANSVERSAL LOUVRE | HONEYCOMB LOUVRE | VISOR | VISOR + TRANSVERSAL LOUVRE | LINEAR PRISMATIC SCREEN | SATIN SCREEN |
| WHITE | WGS | UE19 - UE26 - UE33 - UE40 - UE47 - UE54 - UE61 UE68 - UE75 - UE82 - UE89 - UE96 - UF03 - UF10 UF17 - UF24 - UF31 - UF38 - UF45 - UF52 - SA92 SB01 - SB10 - SB19 - SB28 ILL27S-XX-BO-XXX-WGS | ✓ | ✓ | ✓ | ✓ | ✓ | ✓ | ✓ |
| | WGM | UE20 - UE27 - UE34 - UE41 - UE48 - UE55 - UE62 UE69 - UE76 - UE83 - UE90 - UE97 - UF04 - UF11 UF18 - UF25 - UF32 - UF39 - UF46 - UF53 - SA93 SB02 - SB11 - SB20 - SB29 ILL27S-XX-BO-XXX-WGM | ✓ | ✓ | ✓ | ✓ | ✓ | ✓ | ✓ |
| | WGW | UE21 - UE28 - UE35 - UE42 - UE49 - UE56 - UE63 UE70 - UE77 - UE84 - UE91 - UE98 - UF05 - UF12 UF19 - UF26 - UF33 - UF40 - UF47 - UF54 - SA94 SB03 - SB12 - SB21 - SB30 ILL27S-XX-BO-XXX-WGW | ✓ | ✓ | ✓ | ✓ | ✓ | ✓ | ✓ |
| | FLOOD | UE22 - UE29 - UE36 - UE43 - UE50 - UE57 - UE64 -UE71-UE78-UE85-UE92-UE99-UF06-UF13-UF20- UF27-UF34-UF41-UF48-UF55-SA95-SB04-SB13-SB22-SB31 ILL27S-XX-BO-XXX-FL | ✗ | ✓ | ✓ | ✓ | ✓ | ✓ | ✓ |
| | WIDE FLOOD | UE23-UE30-UE37-UE44-UE51-UE58-UE65-UE72- UE79-UE86-UE93-UF00-UF07-UF14-UF21-UF28-UF35- UF42-UF49-UF56-SA96-SB05-SB14-SB23-SB32 ILL27S-XX-BO-XXX-WF | ✗ | ✓ | ✓ | ✓ | ✓ | ✓ | ✓ |
| | WG NO DOT | UE24-UE31-UE38-UE45-UE52-UE59-UE66-UE73- UE80-UE87-UE94-UF01-UF08-UF15-UF22-UF29-UF36- UF43-UF50-UF57-SA97-SB06-SB15-SB24-SB33 ILL27S-XX-BO-XXX-WG | ✓ | ✓ | ✓ | ✓ | ✓ | ✗ | ✓ |
| | GL NO DOT | UE25-UE32-UE39-UE46-UE53-UE60-UE67-UE74- UE81-UE88-UE95-UF02-UF09-UF16-UF23-UF30-UF37- UF44-UF51-UF58-SA98-SB07-SB16-SB25-SB34 ILL27S-XX-BO-XXX-GL | ✗ | ✓ | ✓ | ✓ | ✓ | ✗ | ✗ |
| | SPOT | S965-S966-S967-S968-S969-S970-S971-S972-S973- S974-S975-S976-S977-S978-S979-S980-S981-S982-S983- S984-S985-S986-S987-S988-S989-S990-S991-S992-S993- S994-S995-S996-S997-S998-S999-ILL27S-XX-BO-XXX-SP | ✗ | ✓ | ✓ | ✓ | ✓ | ✓ | ✓ |
| | ELLIPTICAL | S977-S978-S979-S980-S981-S982-S983-S984-S985- S986-S987-S988-S989-S990-S991-S992-S993-S994- S995-S996-S997-S998-S999-ILL27S-XX-BO-XXX-ELL | ✗ | ✓ | ✓ | ✓ | ✓ | ✗ | ✓ |
| WHITE + MICROLOUVRE | WGS-ML | UF59-UF62-UF65-UF68-UF71-UF74-UF77-UF80-UF83- UF86-UF89-UF92-UF95-UF98-UG01-UG04-UG07- UG10-UG13-UG16-SB37-SB40-SB43-SB46-SB49 ILL27S-XX-BO-XXX-WGS-ML | ✗ | ✗ | ✗ | ✓ | ✗ | ✗ | ✗ |
| | WGM-ML | UF60-UF63-UF66-UF69-UF72-UF75-UF78-UF81-UF84- UF87-UF90-UF93-UF96-UF99-UG02-UG05-UG08- UG11-UG14-UG17-SB38-SB41-SB44-SB47-SB50 ILL27S-XX-BO-XXX-WGM-ML | ✗ | ✗ | ✗ | ✓ | ✗ | ✗ | ✗ |
| | WGW-ML | UF61-UF64-UF67-UF70-UF73-UF76-UF79-UF82-UF85- UF88-UF91-UF94-UF97-UG00-UG03-UG06-UG09- UG12-UG15-UG18-SB39-SB42-SB45-SB48-SB51 ILL27S-XX-BO-XXX-WGW-ML | ✗ | ✗ | ✗ | ✓ | ✗ | ✗ | ✗ |

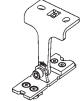
PROTECTION ACCESSORIES + MOUNTING ACCESSORIES

| PROTECTION FRAME | Mounting S1 | Mounting M2 to M9, G2 to G9, U2 to U9 | | |
|---|---|---|---|---|
| |  |    |  |  |
| | X693 - X694 - X760 | X688 - X689 X690 - X691 | X747 - X748 X749 - X750 | X770 - X771 X772 |
|  | ✗ | ✓ | | |

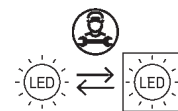

iGuzzini
9320 Boul. St-Laurent
Suite 100,
Montréal (Québec)
Canada H2N 1N7
P: 514. 523.1337
F: 514.525.6107
www.iguzzini.com/us
VL - 14.08.2024

Headquarters iGuzzini illuminazione spa
via Mariano Guzzini, 37 - 62019 Recanati Italy